

institut Max von Laue  
Paul Langevin  
Grenoble - France

# ANNUAL REPORT 1991

Institut  
Max von Laue-  
Paul Langevin



Grenoble - France

# ANNUAL REPORT 1991



On 20 October 1991 the 100<sup>th</sup> Anniversary of the birth of Sir James Chadwick was celebrated in the scientific communities all over the world. In particular at the ILL, the most renowned neutron research centre in the world, this date was honoured, since Sir James was the discoverer of the neutron (Nobel Prize in 1935). The ILL's amphitheatre was named after this great scientist.

### **Front cover:**

Crystal structure of the lowest temperature phase of Benzene: Hexafluorobenzene as seen by looking along the *c*-direction. The structure was solved from the powder pattern by a combination of neutron (D1A) and synchrotron (High-Resolution Diffractometer 2.3, Daresbury) scattering.

## CONTENTS

---

– <i>THE INSTITUT MAX VON LAUE - PAUL LANGEVIN</i>	<i>P. 4</i>
– <i>ORGANISATION OF THE ILL</i>	<i>P. 5</i>
– <i>VISITS AND EVENTS</i>	<i>P. 7</i>
– <i>DIRECTOR'S REPORT</i>	<i>P. 10</i>
– <i>ILL/ESRF COOPERATION</i>	<i>P. 16</i>
– <i>COLLEGES</i>	<i>P. 17</i>
– <i>INSTRUMENT OPERATION DEPARTMENT</i>	<i>P. 89</i>
– <i>DIRECTORATE SERVICES</i>	<i>P. 107</i>
– <i>INSTRUMENT AND METHODS DEPARTMENT</i>	<i>P. 111</i>
– <i>COMPUTING DEPARTMENT</i>	<i>P. 115</i>
– <i>REACTOR DIVISION</i>	<i>P. 120</i>
– <i>ADMINISTRATION DEPARTMENT</i>	<i>P. 121</i>
– <i>COMMUNICATIONS</i>	<i>P. 127</i>

The Institut Max von Laue-Langevin (ILL) at Grenoble was formally founded in January 1967, with the signature of an intergovernmental convention between France and the Federal Republic of Germany. The aim was to provide the scientific community of the affiliated countries with a unique neutron beam facility applicable in fields such as the physics of condensed matter, chemistry, biology, nuclear physics and materials science. The construction of the Institut and its high flux reactor was undertaken as a joint French-German project, with a total capital investment of 335 million FF. The reactor went critical in August 1971 and reached its full power of 57 MW for the first time in December 1971. The year 1972 saw the start-up of the cold and hot sources, the first instruments and the beginning of the experimental programme.

On January 1st, 1973 the United Kingdom joined the Institut as a third equal partner, contributing its share to the total capital investment. The corresponding intergovernmental convention was formally signed in July 1974 by the pertinent ministers from the three affiliated countries. On December 9, 1981 a protocol was signed by representatives from the three member countries which extended the agreement until 1992 and beyond unless two years' notice of termination has been given.

In December 1986, an agreement on "Scientific Membership" of Spain was signed by the ILL and the Spanish Interministerial Commission on Science and Technology for a period of five years starting on January 1st, 1987. Switzerland became another "associated scientific member" of the Institut in 1988 as well as Austria in 1990. The pertinent agreement between the ILL and the Austrian Academy of Sciences was signed in April 1990.\*)

The ILL is a non-trading company under French civil law.

The three countries are represented by the following Associates:

- Kernforschungszentrum Karlsruhe GmbH, Germany
- Centre National de la Recherche Scientifique, France
- Commissariat à l'Energie Atomique, France
- Science and Engineering Research Council, United Kingdom.

These Associates are represented on a Steering Committee, which establishes the general rules of the management of the ILL. The Institut is headed by a Director and two Assistant Directors, all with a five year tenure, the former to be nominated alternately by the German and the British Associates, the other two by the remaining Associates. A Scientific Council, nominated by the Associates, advises the Directors on the scientific programme and on practical aspects relating to its operation. The scientific users' community of the ILL is represented in 8 subcommittees of the Scientific Council, which meet twice a year to select those research proposals which are to be carried out at the neutron beam facilities of the ILL. A further subcommittee of the Scientific Council deals with questions of instrumentation, serving as a discussion platform between the ILL and its external users. The purpose of the ILL thus differs from other research institutes in so far as it is a service institute created so that chemistry, solid state physics, fundamental and nuclear physics, biology and metallurgy specialists from laboratories in the partner countries can use the unique power of neutron techniques to broaden the attack on their problems. Designing and operating instruments and helping the visiting users to carry out their experiments is thus the principal task of the Institut's own scientists. The experimental use of the instruments by ILL staff is subject to the same approval system as their use by external teams.

\*) Under these agreements Spanish, Swiss and Austrian scientists have access to the ILL facilities under the same conditions as the three member countries and have the possibility of sending two thesis students. A seat is reserved for a Spanish, Swiss and Austrian scientist in the ILL Scientific Council as well as membership in two of our sub-committees. The participation of Spain, Switzerland and Austria to the ILL Budget is limited to 1.5% each.

**Associates of the ILL**

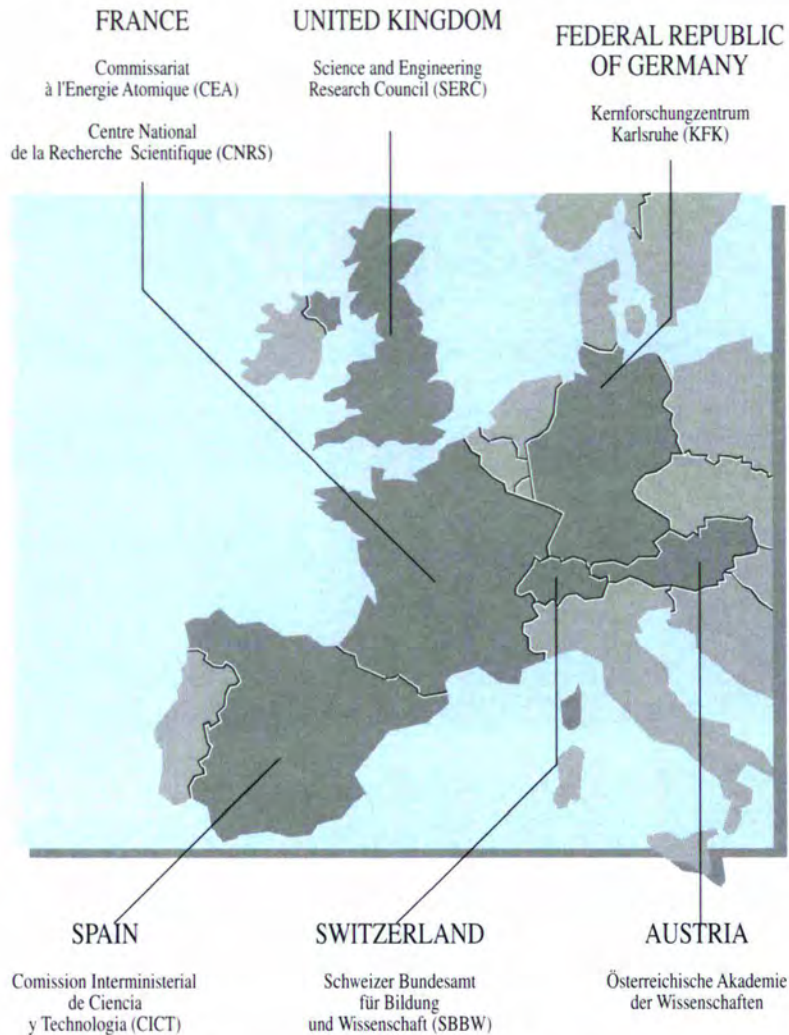

**Countries with scientific membership**

<b>Steering Committee</b> (at its last meeting)		
○ Hansen (BMFT)	○ Aymar (CEA)	○ Newport (SERC)
○ Klose (KFK)	○ Bouchard (CEA)	○ Richards (Univ. Durham)
○ Schunck (BMFT)	○ Comès (CNRS)	○ Voss (RAL)
○ Steiner (Univ. Mainz)	○ Sevin (CNRS)	○ Wilkins (SERC)

<b>Scientific Council</b>	
<b>Plenary Session</b> 30 members	<b>Subcommittees</b> 66 members

# GENERAL ORGANIGRAM

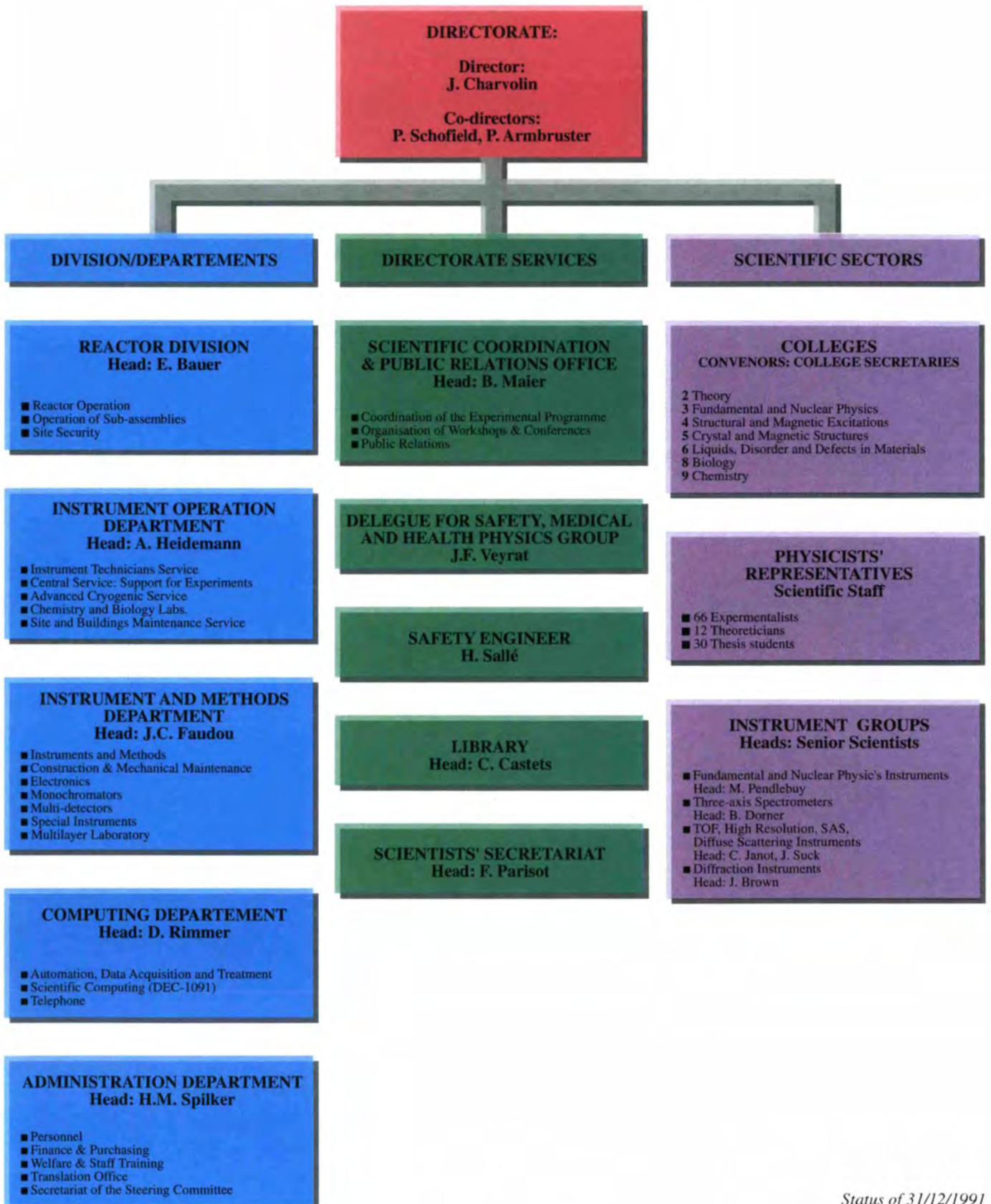

Status of 31/12/1991

## "VISITS AND EVENTS" IN 1991



On 2 October 1991 members of the Committee for Research and Technology of the German Parliament (Bundestag) visited the ILL and the ESRF. In the picture they receive explanations from Prof. Armbruster (third from left).



On 26 November 1991 the Advisory Committee for Large Installations of the Commission of the European Communities visited the ILL. On their tour through the ILL they were guided by Prof. Armbruster (fourth from left) and B. Maier (left).



Prof. A. Müller (centre) receives explanations from B. Dorner.

During the past year the ILL had pleasure in receiving two distinguished scientists: Prof. K.A. Müller (Nobel Prize winner in Physics 1987) and Prof. R. Huber (Nobel Prize winner in Chemistry 1988) on 19 September and 24 October 1991, respectively.



Prof. R. Huber (left) with Prof. P. Armbruster.

## "VISITS AND EVENTS" IN 1991

*On 1 October 1992 Prof. W. Klose, Chairman of the ILL Steering Committee, introduced Prof. J. Charvolin as Acting Director, and Dr. P. Schofield, successor of Prof. P. Day whose tenure ended on 30 September 1991, as new British Assistant Director. A ceremony was held in the Chadwick amphitheatre on this occasion and was followed by a drink.*



*The picture shows the new ILL Management team. Left: Prof. J. Charvolin, centre: Dr. P. Schofield, right: Prof. P. Armbruster, assisted by Prof. W. Klose (second from left) and E. Bauer, Head of the Reactor Division (second from right).*



*Prof. Klose (right) and Dr. Schofield have a drink together.*

*The ILL users' meeting on 17 October 1991 has been a considerable success.*

*The participants thronging at the reception.*



*The Palais de la Source at Uriage was an ideal and pleasant setting for the event.*

## "VISITS AND EVENTS" IN 1991



*About 300 participants listened to the talks concerning the reconstruction of the HFR and the instrument development programme.*



*Prof. J. Charvolin, Acting ILL Director, gave a summary of the HFR problems*



*Prof. P. Armbruster chaired the discussions about the modernization programme.*



*Lunch was served in a marquee close to the Palais de la Source.*

**L**e réacteur, cœur de l'institut, est arrêté depuis le 30 mars et ne sera pas remis en fonctionnement avant 1994. Cet événement a non seulement interrompu certains aspects de l'activité scientifique de l'institut, mais aussi lui impose de reconsidérer ses plans à moyen terme : développement instrumental, distribution du personnel, relations avec les communautés scientifiques des utilisateurs et les autres centres. Si la fonction de l'institut était de développer un parc instrumental et une vie scientifique propres à garantir l'accueil le plus efficace possible des utilisateurs, il doit maintenant assurer la remise en état la plus rapide possible de son réacteur, c'est-à-dire la mise en place et le bon déroulement d'un important et coûteux projet d'ingénierie nucléaire, tout en préservant ses potentiels instrumental et scientifique. Ce changement brutal d'orientation doit de plus être assuré dans un contexte assez difficile du fait de contraintes budgétaires et de la renégociation envisagée de la Convention Intergouvernementale régissant l'institut.

Les difficultés des gouvernements des trois pays membres à financer au mieux leurs programmes de développements scientifique et technologique sont bien connues, comme le sont les exemples de laboratoires dont les budgets 92 sont en diminution par rapport aux budgets 91, la situation de l'institut avec un budget presque constant entre 91 et 92 pourrait sembler favorable s'il ne devait trouver dans ce budget les ressources nécessaires et importantes pour financer la remise en état de son réacteur, c'est-à-dire en réduisant le développement prévu de ses programmes. Cette situation devrait se prolonger en 93 mais nous ne pouvons envisager plus loin car le montant total de la participation financière des Associés est incertain en 94 et au-delà, en raison du souhait exprimé par l'Associé britannique de voir renégocier la Convention Intergouvernementale en diminuant sa contribution. Autrement dit, c'est en deux ans que l'institut doit constituer la réserve qui lui permettra de démarrer le plus vite possible la remise en état de son réacteur. Ceci signifie évidemment que cette opération sera accompagnée d'une réduction temporaire d'activité dans les autres domaines de l'institut étant bien entendu que cette réduction doit être suivie d'une relance après 1993. Ce rapport va donc présenter rapidement la situation, ses conséquences sur les différentes activités de l'institut et comment il envisage y faire face.

### Arrêt du réacteur

Compte tenu de son extrême importance ce point fera l'objet d'un rapport détaillé de M. Bauer, responsable de la Division Réacteur. Je serai donc bref, me limitant à l'évocation des principales étapes de l'évolution du problème.

Le 30 mars, alors que le réacteur est arrêté après un cycle de fonctionnement normal, une inspection de routine détecte des traces inhabituelles sur une grille de tranquillisation de

l'écoulement d'eau lourde à l'intérieur du bidon réflecteur ; le 5 avril, après une analyse approfondie, il apparaît que ces traces correspondent à des fissures traversantes dans la grille qui doit donc être changée. Un tel changement implique une grande intervention dans le bidon réflecteur, elle-même précédée d'une longue préparation. L'institut espère alors pouvoir renforcer la grille pour permettre un redémarrage temporaire pendant la période de préparation mais, la poursuite des investigations ayant permis de bien comprendre l'origine des dommages, il renonce à cet espoir devant l'ampleur des travaux de renforcement et décide le 10 juillet de maintenir le réacteur à l'arrêt pour attaquer immédiatement la réflexion sur la grande intervention. Les options techniques possibles, ainsi qu'une première évaluation de leurs coûts et durées, sont proposées fin septembre aux Associés qui demandent alors à l'institut de préparer une analyse détaillée de l'option avec changement complet du bidon réflecteur et de ses structures internes pour fin janvier 1992, afin de leur fournir tous les éléments nécessaires à leur prise de décision. Les coût et durée de cette option avaient été estimés pendant l'été à 150 MF et 28 mois respectivement et le travail en cours devra asseoir ces estimations sur la base solide d'engagements industriels.

Depuis le 30 mars les équipes de la Division Réacteur sont engagées dans un travail d'analyse et de proposition remarquable de rigueur et d'efficacité, elles doivent être remerciées au nom de tout l'institut.

### Financement de la remise en état du réacteur

Comme déjà dit plus haut ce financement doit être assuré à partir d'une réserve adéquate constituée sur les budgets des années 1991 (313 MF), 92 et 93 (310 MF). En 1991, en raison de la date tardive de la décision définitive de maintenir le réacteur à l'arrêt il ne fut pas possible de contribuer à cette réserve de façon importante et la majorité des économies va être réalisée en 1992-93. Une partie de la somme a été évidemment trouvée dans les conséquences immédiates de l'arrêt du réacteur : combustible, électricité, fluides cryogéniques des expériences, financement des visiteurs, arrêt du recrutement de scientifiques. Mais ceci n'a pas été suffisant et il a été nécessaire de reconsidérer le calendrier du plan de développement de l'institut, de favoriser le départ de personnels proches de la retraite, d'encourager les détachements vers d'autres laboratoires, et de bloquer les recrutements sur les postes libérés. L'application de ces mesures dès la fin 1991 permet d'envisager d'assurer la moitié de la réserve en 1992. Un travail semblable devra être poursuivi en 1992 pour apporter le complément nécessaire en 1993. Enfin, si le raffinement de l'évaluation des coûts attendu pour fin janvier 92 entraînait une révision à la baisse de ces derniers, la partie de la réserve non utilisée par le réacteur pourrait être reversée dans le programme instrumental avec l'accord des Associés.

La nouvelle équipe de direction a donc dû, dès sa prise de fonction le 1<sup>er</sup> octobre 1991, mettre en place des mesures très difficiles. Heureusement, la confiance et la compréhension manifestées à son égard par tous les membres de l'institut lui ont apporté un soutien et une aide considérables.

### Plan de développement instrumental

Le plan de développement, incluant les instruments financés par le budget normal et ceux proposés pour être financés par un budget exceptionnel (dit "Troisième Souffle" ou "Second Plan de Modernisation", prévu sur 5 ans à partir de 1993), préparé en 1989/90 par le précédent directeur, P. Day, a été présenté au Comité de Direction de mai 1991. Suite aux recommandations de ce Comité de Direction, et prenant en compte les contraintes nouvelles introduites par la remise en état du réacteur, notre directeur allemand, P. Armbruster, a remanié les propositions précédentes. Le résultat de ce travail est décrit dans le rapport de P. Armbruster consacré à ce point. Il s'agit bien sur d'un plan réduit par rapport aux ambitions initiales mais qui a été organisé de façon à affirmer les spécificités de l'institut, neutrons froids et polarisés, complémentaires de celles des autres centres. Ce nouveau plan a été soumis aux utilisateurs intéressés rassemblés en un "Users' Meeting" le 17 octobre puis au Conseil Scientifique du 18 octobre. A l'assentiment recueilli pendant ces deux réunions s'est ajouté l'accueil favorable réservé par le Comité de Direction de novembre 1991 et son approbation du choix d'instruments présenté par l'institut. Il est évident, dans la situation actuelle et sans connaître le coût exact de la remise en état du réacteur, qu'aucune décision ne peut être prise concernant le démarrage de nouveaux travaux dans ce programme. Cependant, le Comité de Direction a enregistré favorablement l'intention de l'institut de préparer des analyses détaillées de coûts et calendriers pour certains projets. Ces travaux préparatoires permettront par ailleurs de mettre à l'épreuve la nouvelle structure de gestion des projets qui sera mise en place à l'issue des réflexions sur les structures de l'institut.

La préparation du "Second plan de modernisation" a une longue histoire et a connu de nombreuses péripéties, elle a mobilisé beaucoup des énergies de l'institut, stimulé sa créativité et suscité beaucoup d'espoirs. Nous pensons que la proposition actuelle est un choix d'instruments permettant une bonne évolution de l'institut aussi bien en lui-même que par rapport aux autres centres. Nous souhaitons pouvoir aborder sa réalisation dès que possible.

### Vie à l'institut pendant l'arrêt

Pendant cette période d'arrêt une très grande activité a été et sera concentrée autour du réacteur pour sa remise en état mais ceci ne signifie pas que le reste de l'institut est, ou sera, à l'arrêt. Il a tout d'abord fallu démonter et remiser les

instruments des niveaux "C" et "D" pour libérer l'accès au cœur du réacteur. Des équipes des Départements Exploitation des Expériences, Instruments et Méthodes, et Réacteur sont intervenues avec une excellente coordination et une grande efficacité, elles devront intervenir de nouveau au moment délicat du remontage. Entre démontage et remontage ces mêmes équipes pourront effectuer les travaux de maintenance et amélioration des équipements d'expériences qu'il n'était pas toujours facile d'assurer en période de fonctionnement normal alors qu'elles étaient soumises à la pression du service à rendre aux utilisateurs. Les équipes du Département Instruments et Méthodes vont pouvoir envisager terminer la construction de certains instruments toujours ralenties par la même pression, celles du Département Informatique réfléchir au transfert vers UNIX. Du temps pourra enfin être libéré pour être utilisé pour un enrichissement des compétences en allant à la rencontre de problèmes différents, ou de façons différentes d'envisager les problèmes habituels, éventuellement à l'occasion de détachements, mises à dispositions ou congés sabbatiques dans d'autres instituts ou laboratoires.

Cette période d'arrêt doit donc être vue comme celle du grand "carénage" de tout l'institut : réacteur, parc instrumental, idées, sans oublier la réorganisation de ses structures de gestion demandée par les Associés.

### Nouvelle équipe de direction

Suite au départ de P. Day le 30 septembre 1991, que nous remercions pour son action passée et à qui nous souhaitons tout le succès possible à la tête de la "Royal Institution" de Londres, une nouvelle équipe de direction a été mise en place le 1<sup>er</sup> octobre 1991 par le Professeur W. Klose, Président du Comité de Direction. Cette équipe est constituée de MM. P. Armbruster, P. Schofield et J. Charvolin. D'ores et déjà il a été décidé que P. Armbruster suivra plus particulièrement le secteur scientifique et P. Schofield les départements techniques. Il s'agit là d'un début de répartition des tâches dans l'esprit de la réorganisation prévue des structures de gestion, cette même gestion étant discutée chaque semaine au sein d'un "Management Board" composé de trois Directeurs, du responsable de la Division Réacteur, M. Bauer, et du responsable du Département Administratif et Financier, M. Spilker.

J. Charvolin

**A**m 30. März wurde der Hochflussreaktor, Herz des Instituts, bis voraussichtlich 1994 ausser Betrieb gesetzt. Dieses Ereignis hat nicht nur gewisse wissenschaftliche Aktivitäten des Instituts lahmgelegt, sondern zwingt es auch, seine mittelfristigen Pläne zu überdenken, wie z.B. auf dem Gebiet der Instrumentenentwicklung, der Personalverteilung, und der Beziehungen zur Benutzergemeinde und den anderen Forschungszentren. Bisher waren die Entwicklung seines Instrumentenarsenals und die Aufrechterhaltung eines eigenen wissenschaftlichen Lebens zur möglichst effizienten Benutzerbetreuung die Hauptaufgaben des Instituts, jetzt geht es darum sich um die möglichst schnelle Instandsetzung seines Reaktors zu kümmern, d.h. um die Inangriffnahme eines wichtigen und kostspieligen Projektes auf dem Gebiet des kerntechnischen Ingenieurwesens unter Bewahrung des instrumentellen und wissenschaftlichen Potentials. Diese abrupte Orientierungsänderung muss darüberhinaus, aufgrund der Haushaltsbeschränkung und der bevorstehenden Neuverhandlung des für das ILL gültigen Regierungsabkommens, unter ziemlich schwierigen Umständen vollzogen werden.

Die Regierungen der 3 Mitgliedsländer haben bekanntlich Schwierigkeiten, ihre wissenschaftlichen und technischen Entwicklungsprogramme zu finanzieren. Dies bezeugen die vielen Beispiele von Forschungslaboratorien, deren Budgets 1992 gegenüber 1991 reduziert wurden. Verglichen hierzu könnte die Situation des Instituts mit einem konstanten Budget 1992 bezogen auf 1991 (bei fast konstantem Wert des Franc) zunächst günstig erscheinen, wäre da nicht die Erfordernis, die notwendigen und grossen Finanzmittel zur Finanzierung der Reaktorinstandsetzung zu finden und infolgedessen bei der vorgesehenen Entwicklung seiner Programme sparen zu müssen. Diese Situation wird sich auch 1993 fortsetzen; für 1994 oder gar darüberhinaus können wir keine Vorhersagen treffen, zumal der Gesamtbetrag der finanziellen Beteiligung der Gesellschafter für diese Periode ungewiss ist, angesichts des Wunsches des britischen Gesellschafters über das Regierungsabkommen unter Verminderung seines Beitrags neu zu verhandeln.

Anders ausgedrückt, das ILL muss in den 2 Jahren die Reserve zur baldmöglichen Instandsetzung seines Reaktors ansparen. Dies bedeutet offensichtlich, dass diese Massnahme von einer vorübergehenden Aktivitätsminderung auf den anderen Gebieten des ILL begleitet wird, wobei selbstverständlich der Reduzierung nach 1993 ein Aufschwung folgen muss. Der nachfolgende Bericht fasst kurz die Situation und die Konsequenzen für die verschiedenen Aktivitäten zusammen und zeigt, wie das ILL diesen Problemen begegnet.

### Reaktorstopp

Aufgrund seiner grossen Wichtigkeit wird dieses Thema ausführlich im Bericht der Reaktorabteilung (M. Bauer) behandelt. Ich werde mich deshalb kurz fassen und mich auf die wichtigsten Etappen bei der Verfolgung des Problems beschränken.

Am 30. März, anlässlich einer Abschaltung nach einem normalen Betriebszyklus, entdeckte man bei einer Routineinspektion ungewöhnliche Spuren an einem Strömungsgitter zur Beruhigung des Schwerwasserflusses im Inneren des Reflektortanks. Nach eingehender Untersuchung erwies sich am 5. April, dass diese Spuren mit durchgehenden Sprüngen im Gitter identisch sind, wodurch dessen Auswechslung erforderlich wird. Eine derartige Reparatur bedeutet einen grossen Eingriff im Reflektortank und erfordert eine lange Vorbereitungszeit. Das ILL hoffte zunächst, dieses Strömungsgitter verstärken zu können, um wenigstens einen vorübergehenden Reaktorbetrieb zur Überbrückung der Vorbereitungszeit zu ermöglichen.

Die weiteren Untersuchungen zur Aufklärung der Schadensursache haben diese Hoffnung aufgrund des erforderlichen Aufwands zur Verstärkung des Gitters zunichte gemacht; deshalb entschied das ILL am 10. Juli den Reaktorstopp aufrechtzuerhalten, um sofort mit der Planung des grossen Eingriffs zu beginnen. Ende September wurden die technisch möglichen Optionen sowie eine erste Abschätzung ihrer Kosten und ihrer Dauer den Gesellschaftern vorgelegt. Diese ihrerseits forderten bis Ende Januar 1992 vom ILL eine detaillierte Analyse der Option zum vollständigen Ersatz des Reflektortankes und seiner inneren Strukturen, um alle nötigen Elemente zur Entscheidungsfindung vorliegen zu haben. Kosten und Dauer dieser Option wurden im Sommer dieses Jahres auf 150 MF bzw. 28 Monate geschätzt; die gegenwärtig laufenden Arbeiten haben zum Ziel, diese Abschätzungen auf eine solide industrielle Basis zu stellen.

Seit dem 30. März sind die Mannschaften der Reaktorabteilung mit konsequenten und effizienten Analysen und Vorschlägen beschäftigt. Das gesamte Institut ist ihnen hiermit zu Dank verpflichtet.

### Finanzierung der Reaktorinstandsetzung

Wie bereits oben erwähnt muss diese Finanzierung durch adäquate Reserven aus den Budgets der Jahre 1991 (313 MF), 1992 und 1993 (310 MF) abgesichert werden. Es war nicht möglich, bereits 1991 aufgrund des späten Zeitpunkts der endgültigen Entscheidung über die Aussetzung des Reaktorbetriebs, wesentlich zur erforderlichen Reserve beizutragen; deshalb muss der Grossteil der Einsparungen in den Jahren 1992-93 geleistet werden. Ein Teil der erforderlichen Rücklagen waren unmittelbare Folgen des Reaktorhalts: Brennelemente, Elektrizität, Kühlflüssigkeiten für Experimente, Bezahlung von Gastforschern, Einstellungsstopp für Wissenschaftler. Die somit erstellte Reserve war jedoch immer noch unzureichend und deshalb musste der Zeitplan für das Modernisierungsprogramm des ILL revidiert, das Ausscheiden von Personal nahe an der Pensionsgrenze begünstigt, die Abordnung an andere Laboratorien unterstützt und ein vorläufiger Einstellungsstopp für freiwerdende Posten verfügt werden. Die Einführung all dieser Massnahmen vom Ende des Jahres 1991 an, erlaubt es im Jahre 1992 bereits, die Hälfte der notwendige Reserve anzusparen. Ähnliche Vorkehrungen müssen auch 1992 fortgesetzt werden, um im Jahre 1993 die fehlende Ergänzung der Reserve zu erreichen. Sollte

schliesslich die bis Ende Januar 92 erwartete detaillierte Kostenanalyse weniger hoch ausfallen (als die ursprüngliche grobe Abschätzung), würde mit Einverständnis der Gesellschafter der nicht für die Reaktorreparatur in Anspruch genommene Teil der Reserve in das Instrumentenprogramm investiert werden. Seit ihrer Amtsübernahme am 1. Oktober 91 musste die neue Direktion also sehr schwierige Massnahmen treffen. Glücklicherweise haben ihr das Vertrauen und das entgegengebrachte Verständnis der Belegschaft Unterstützung und beträchtliche Hilfe zuteil werden lassen.

### Modernisierungsplan der Instrumente

Der Entwicklungsplan der Instrumente, einschliesslich der vom Normalbudget sowie der durch ein Sonderbudget finanzierten Geräte (genannt "Troisième Souffle" oder 2. Modernisierungsplan gültig ab 1993 für einen Zeitraum von 5 Jahren), war 1989/90 von P. Day, dem amtierenden Direktor ausgearbeitet und dem Lenkungsausschuss im Mai 1991 vorgelegt worden. Gemäss den Empfehlungen des Lenkungsausschusses und unter Berücksichtigung der neuen durch die Reaktorinstandsetzung hinzugekommenen Randbedingungen, oblag es dem deutschen Direktor, P. Armbruster, diesen ersten Vorschlag nochmal zu überarbeiten. Das Ergebnis dieser Arbeit fand in einem entsprechenden Bericht seinen Niederschlag. Selbstverständlich handelt es sich um ein, gemessen an den anfänglichen Zielen reduziertes Programm; es wurde jedoch so strukturiert, dass es den spezifischen Stärken des Instituts, d.h. kalte und polarisierte Neutronen als Ergänzung zu den Neutronenstrahlen anderer Zentren, gerecht wird. Dieses neue Programm wurde den interessierten ILL Benutzern am 17. Oktober auf einem zu diesem Zweck organisierten Treffen vorgestellt und dann dem Wissenschaftlichen Rat am 18. Oktober vorgelegt. Der Plan fand auf beiden Veranstaltungen allgemeine Zustimmung; ebenso positiv stand ihm der Lenkungsausschuss auf seiner Sitzung im November gegenüber, der die vom ILL getroffenen Auswahl der Instrumente billigte. Es ist klar, dass in der gegenwärtigen Lage und ohne Kenntnis der genauen Instandsetzungskosten des Reaktors, keine Entscheidung bezüglich des Arbeitsbeginns für dieses Programm getroffen werden kann. Dagegen hat der Lenkungsausschuss wohlwollend die Absicht des ILL zur Kenntnis genommen, detaillierte Kostenabschätzungen und Zeitpläne für gewisse Projekte erstellen zu lassen. Diese Vorbereitungen werden es darüberhinaus erlauben, die neue Organisationsstruktur für diese Projekte zu testen, welche im Rahmen der Modernisierung der Gesamtstruktur des ILL eingeführt werden wird.

Die Vorbereitung des "2. Modernisierungsprogramms" hat eine lange Geschichte und musste zahlreiche Rückschläge erfahren; sie hat viel Energie des Instituts mobilisiert, die Kreativität stimuliert und viel Hoffnung geweckt. Wir sind der Meinung, dass die gegenwärtige Auswahl von Instrumenten dem ILL eine gute Entwicklung erlauben wird, nicht nur was sein eigenes wissenschaftliches Leben betrifft sondern auch im Hinblick auf seine Beziehungen zu anderen Forschungszentren. Wir wünschen uns die baldige Verwirklichung des Programms.

### Das wissenschaftliche Leben des ILL während der Betriebspause des Reaktors

Während der bisherigen Reaktorbetriebspause hat sich eine intensive Aktivität um den Reaktor und seine Wiederinstandsetzung entfaltet; auch in den folgenden Jahren bis zur Wiederinbetriebnahme wird dies so sein, was jedoch nicht bedeutet, dass der Rest des ILL brachliegt oder untätig sein wird. Zunächst mussten alle Instrumente der Reaktorétagen "C" und "D" abmontiert und geeignet gelagert werden, um Zugang zu den inneren Reaktoreinbauten zu schaffen. Die Mannschaften der Abteilungen "Experimentierbetrieb", "Instrumente und Methoden", sowie die Reaktorabteilung haben sich aufgrund hervorragender Koordination und grosser Effizienz dieser Aufgabe schnell entledigt. Sie müssen aufs neue zum Zeitpunkt des Wiederaufbaus intervenieren. Zwischen Ab- und Aufbau werden diese Mannschaften solche Umrüstungs- und Verbesserungsarbeiten der Experimentiereinrichtungen vornehmen können, welche während der normalen Betriebsperiode, wo sie dem Dienstleistungsdruck für die Reaktorbenutzer unterliegen, nur schwer bewerkstelligt werden konnten. Die Spezialisten der Abteilung "Instrumente & Methoden" werden somit Gelegenheit haben, den aufgrund dieser Inanspruchnahme verzögerten Aufbau gewisser Geräte zu vollenden; die Abteilung "Informatik" wird sich mit der Umrüstung der Geräte auf das Rechnersystem UNIX beschäftigen. Schliesslich wird Zeit zur Verfügung stehen, um sich Kompetenzen auf anderen Gebieten anzueignen, oder den gewohnten Problemen mit anderen Methoden zu begegnen, gegebenenfalls anlässlich einer Abordnung oder eines "sabbatical" in anderen Forschungsinstituten.

Diese Betriebspause ist also eine Gelegenheit zu einer Generalüberholung des Instituts, d.h. des Reaktors, des Instrumentenarsenals, der Ideen und nicht zuletzt zur Durchführung der von den Gesellschaftern geforderten Reorganisation der Strukturen.

### Neue Direktion

Als Folge des Ausscheidens von P. Day am 30. September 1991, dem wir für seine Arbeit danken und dem wir viel Erfolg in seiner Funktion als Leiter der "Royal Institution" in London wünschen, wurde am 1. Oktober 91 von W. Klose, Vorsitzender des Lenkungsausschusses eine neue Direktion eingeführt. Diese besteht aus P. Armbruster, P. Schofield und J. Charvolin. Schon jetzt ist klar, dass P. Armbruster sich besonders dem wissenschaftlichen Bereich und P. Schofield den technischen Abteilungen widmen werden. Hierbei handelt es sich um einen Anfang der Aufgabenverteilung im Sinne der vorgesehenen Reorganisation der Managementstrukturen. Diese neue Struktur findet auch in den wöchentlichen Treffen des "Management Board" ihren Ausdruck, welches aus den drei Direktoren, dem Leiter der Reaktorabteilung, Herrn Bauer, sowie dem Verantwortlichen für die Administration und Finanzabteilung, Herrn Spilker, besteht.

J. Charvolin

The reactor, the heart of the ILL, has been shut down since 30<sup>th</sup> March 1991 and will not resume operation before 1994. This event has not only interrupted certain aspects of the ILL's scientific activity, but also necessitates reconsideration of its medium term plans: development of instruments, distribution of staff, relations with the scientific user communities and the other research centres. Whereas the ILL's function has been to develop a range of instruments and a scientific life designed to provide the most efficient possible reception for the users, it now has to ensure that its reactor is refurbished as quickly as possible, which means the setting up and smooth implementation of a large and expensive nuclear engineering project, while conserving its scientific and instrumental potential. This sudden change in orientation also has to take place in a relatively difficult context due to budgetary constraints and the envisaged renegotiation of the intergovernmental convention covering the ILL.

The difficulties of the governments of the three member countries in financing efficiently their scientific and technological development programmes are well known, as are the examples of laboratories whose 1992 budgets are reduced in relation to the 1991 budgets, so that the ILL's situation with an almost constant budget between 1991 and 1992 could appear favourable, if it did not have to find within this budget the considerable resources necessary to finance the refurbishment of its reactor, i.e. by reducing the planned development of its programmes. This situation should continue in 1993, but we cannot anticipate further, as the total financial contributions of the Associates are uncertain in 1994 and beyond, because of the wish expressed by the British Associate for a renegotiation of the intergovernmental convention with a reduction in its contribution. In other words, the ILL must in two years set up the reserve to enable it to start as quickly as possible on the refurbishment of its reactor. This clearly means that this operation will be accompanied by a temporary reduction in activity in other areas of the ILL, on the understanding that this reduction will be followed by a restart after 1993. This report accordingly summarizes the situation, its consequences for the various activities of the ILL and how it is intended to deal with these.

### **Shutdown of the reactor**

In view of its great importance, this point will be the subject of a detailed report by Mr. Bauer, Head of the Reactor Division. I shall therefore be brief, confining myself to a summary of the main stages in the development of the problem.

On 30<sup>th</sup> March, during a reactor shutdown after a normal operating cycle, a routine inspection revealed unusual marks on an anti-turbulence grid in the heavy water in the reactor vessel; on 5<sup>th</sup> April, after a detailed analysis, it was found that these marks were transverse cracks in the grid, which must therefore be replaced. Such an operation implies major intervention work in the reactor vessel, preceded by long preparation. At that time the ILL hoped to be able to strengthen the grid to permit temporary operation during the preparation period but, as the continued investigations gave a better understanding of the origin of the damage, this idea was given up in view of the amount of strengthening work required. It was decided on 10<sup>th</sup> July to keep the reactor shut down and to initiate immediately studies for the major intervention work. The possible technical options, with a first evaluation of their cost and duration, were submitted at the end of September to the Associates, who then requested the ILL to prepare a detailed analysis of the option involving complete replacement of the reflector tank and its internal parts by the end of January 1992, to give them all the elements necessary for a decision. During the summer the cost and duration of this option were estimated at 150 MF and 28 months, respectively, and the work in progress should give these estimates a firm basis of industrial commitments.

Since 30<sup>th</sup> March 1991 the Reactor Division teams have been involved in analysis and proposal work of great precision and efficiency, and I should like to thank them on behalf of the whole of the ILL.

### **Financing of the reactor refurbishment**

As stated above, the refurbishment is to be financed out of a reserve set up in the budgets for the years 1991 (313 MF), 1992 and 1993 (310 MF). In 1991, because of the late date of the final decision to keep the reactor shut down, it was not possible to make any major contribution to this reserve, and the majority of the savings must be effected in 1992-93. Part of this amount has obviously been found in the immediate consequences of the reactor shutdown: fuel elements, electricity, cryogenic fluids for experiments, expenditure on visitors, and suspension of recruitment of scientists. But this was not sufficient, and it was necessary to reconsider the timetable for the ILL's development plan, to encourage personnel close to retirement to leave, to favour secondment to other laboratories and to impose a freeze on recruitment to posts becoming vacant. Application of these measures with effect from the end of 1991 makes it possible to envisage building up half of the reserve in 1992. Similar work must be continued in 1992 to provide the necessary additional amount in 1993. Finally if the more precise

evaluation of the cost due at the end of January 1992 should lead to a downward revision, that part of the reserve not used by the reactor could be returned to the instrument programme, with the Associates' agreement.

The new team of Directors has thus had to implement very difficult measures since it took office on 1<sup>st</sup> October 1991. Fortunately the confidence and understanding shown by all members of the ILL staff have been a great support and assistance to the Directors.

### **Instrument development plan**

The development plan comprising the instruments financed under the normal budget and those proposed to be financed under an exceptional budget (known as the "Second Modernisation Programme", planned for a five year period from 1993), was prepared in 1989/90 by the previous Director, P. Day, and submitted to the Steering Committee in May 1991. Following the recommendations of the Steering Committee, and taking account of the new constraints introduced by the refurbishment of the reactor, our German Director, P. Armbruster, reviewed the original proposals. The result of this work is described in P. Armbruster's report on this subject. This is a plan reduced in relation to the initial ambitions, but which has been organised so as to reaffirm the ILL's specialities - cold and polarised neutrons - which are complementary to those of other research centres. This new plan was submitted to the users concerned, who met at a Users' Meeting on 17<sup>th</sup> October, and then to the Scientific Council on 18<sup>th</sup> October. General agreement was reached at these two meetings, and the plan was favourably received by the Steering Committee in November 1991, which approved the choice of instruments submitted by the ILL. In the present situation, with the exact cost of the reactor refurbishment not yet known, it is clear that no decision can be taken on initiating new work under this programme. However, the Steering Committee noted with approval the ILL's intention to prepare detailed analyses of costs and timetable for certain projects. This preparatory work will also put to the test the new project management structure which will be set up following the considerations on the ILL's structures.

The preparation of the Second Modernisation Programme has had a long history and complicated evolution, and has mobilised a great deal of the ILL's energy, stimulated its creativity and raised many hopes. We consider that the present proposal is a choice of instruments providing for a good development of the ILL, both in itself and in relation to other centres. We should like to be able to start implementing it as soon as possible.

### **Life at ILL during the shutdown**

During this shutdown period there has been and will be a great deal of activity concentrated around the reactor for its refurbishment, but this does not mean that the rest of the ILL is, or will be, at a standstill. It was first of all necessary to dismantle and store the level 'C' and 'D' instruments to provide access to the reactor core. Excellent coordination and great efficiency were shown in this by the groups from the Instrument Operation and Instruments & Methods Departments and the Reactor Division, and they will have to intervene again at the delicate stage of re-installation. Between dismantling and re-installation these same groups will be able to carry out maintenance and improvement work on experimental instruments, which is not always easy to do during a period of normal operation subject to the pressure of service to be provided for users. The groups in the Instruments and Methods Department will be able to envisage completing the construction of certain instruments, which has always been slowed down by the same pressure, and the Computing Department groups will be able to study the transfer to UNIX. Finally it will be possible to find time for enhancing skills by dealing with different problems, or different ways of approaching the usual problems, in some cases in the course of detachment, secondment or sabbatical leave in other institutes or laboratories.

This shutdown period should thus be regarded as a general overhaul of the whole of the ILL: reactor, instruments, ideas, not forgetting the reorganisation of the management structures called for by the Associates.

### **New team of Directors**

Following the departure on 30<sup>th</sup> September 1991 of P. Day, whom we thank for his past work and wish every possible success as Director of the Royal Institution, a new team of Directors was introduced by Professor W. Klose, Chairman of the Steering Committee, on 1<sup>st</sup> October 1991. This team consists of P. Armbruster, P. Schofield and J. Charvolin. From the outset it was decided that P. Armbruster would concentrate on the scientific sector and P. Schofield on the technical departments. This is the beginning of a redistribution of tasks in the spirit of the planned reorganisation of the management structure, this management being discussed every week by a Management Board, consisting of three Directors, the Head of the Reactor Division, Mr. Bauer, and the Head of the Administration and Finance Department, Mr. Spilker.

J. Charvolin

## Instrument Development

At its meeting in November 1988 the Steering Committee requested the then Director of the ILL, W. Gläser, to draw up a plan for a second Modernisation Programme, the 'Troisième Souffle'. At the same time a Commission was set up under the chairmanship of G. Walker, to evaluate the need for and the main lines of development of such a programme. Two years later, in November 1990, his successor, P. Day, submitted a first draft, to be implemented over the period 1992-96, at a cost of 80% of an annual budget, or 237 MF. In June 1991 a draft of half the previous volume with a concentration of the range covered was resubmitted to the Steering Committee and the scientific case was approved. However, clear priorities were to be established by the Directors after discussions in a users' meeting and in the Scientific Council, with a further limitation of the overall cost. Sincere thanks are due to the 300 users, almost all of whom attended the users' meeting on 17<sup>th</sup> October 1991 in Uriage without any financial support from ILL, for their participation and their constructive contributions. Finally in November 1991 a plan was submitted to the Steering Committee for instrumentation after 1994, which will be limited to 30 instruments, and includes the following new instruments, which all use either cold or polarised neutrons.

### Cold polarised neutrons

- 1) SURE Neutron reflectometer,
- 2) PN7B Highly polarised neutron beam for nuclear and elementary particle physics.

### Cold neutrons

- 3) LADI Quasi-Laue spectrometer for large unit cells,
- 4) IN5-TF Time focussing time-of-flight spectrometer.

### Thermal polarised neutrons

- 5) Spectrometer with polarisation analysis in the energy range 35-110 meV,
  - a) D5B Multipurpose diffractometer,
  - b) IN20B Triple-axis spectrometer.

To be able to operate these instruments, two new cold guides and a thermal supermirror guide must be installed. A sputtering facility is required for the development of the many thin layer elements on the cold neutron guides, and the development of a <sup>3</sup>He polariser has been proposed.

The Steering Committee took note of the priorities set. The financing of the programme at a level of 86 MF starting in 1993 is at present completely open. The ILL will appoint project leaders, to plan the projects in detail, so that from 1993 project groups can make a smooth start on the implementation of the instruments. A precondition for the

construction and commissioning of new instruments is the closure of existing, older instruments or their operation by outside groups, and the adaptation of the ILL structure to more modern management methods, to permit the instruments for the nineties to be built with less money in a shorter time. The ILL's success in instrument construction in the seventies is still an incitement and an example for us.

P. Armbruster

## Collaboration with ESRF

Close relations exist with our neighbour, the European Synchrotron Radiation Facility (ESRF), and a Joint Management Committee meets regularly. Many modes of collaboration between our two Institutes are in operation, and more are planned. The Common Building, which will house a new restaurant/cafeteria, the library and the theoreticians from both Institutes, will be completed in 1992, at which time the fence separating two parts of the common site will come down.

Discussions of possible modes of collaboration are held at many levels, including a meeting in Paris in July between representatives of the ESRF Council and the ILL Steering Committee and of both managements. Various working groups have met to discuss such matters as a joint project on instrument control and data acquisition, common chemistry and biology laboratories, accommodation of a joint medical service etc. It is hoped that ILL staff released from normal duties by the reactor closure will be able to help ESRF with their peak load programme during their commissioning over the next two years.

P. Schofield

– COLLEGE 2 THEORY	P. 18
– COLLEGE 3 NUCLEAR AND FUNDAMENTAL PHYSICS	P. 20
– COLLEGE 4 STRUCTURAL AND MAGNETIC EXCITATIONS	P. 29
– COLLEGE 5 CRYSTAL AND MAGNETIC STRUCTURES	P. 37
– COLLEGE 6 LIQUIDS, DISORDERED MATERIALS AND METAL PHYSICS	P. 53
– COLLEGE 8 BIOLOGICAL STRUCTURES AND DYNAMICS	P. 64
– COLLEGE 9 a: MOLECULAR SPECTROSCOPY, SURFACES AND MESOPHASES	P. 69
b: LARGE MOLECULES	P. 78

## Theory

### Members of the College

R.M. Bowley	C. Misbah
J. Chalker	P. Nozières
G.W. Ford	M.D. Nunez-Regueiro
B. Fourcade	J. Palmeri
P. Holdsworth	N. Schopohl
I. Jolie	E.F. Shender
D. Janssen	M. Uwaha
E.I. Kats	J. Voit

### Introduction

The members of the Theory College work on problems of condensed matter and nuclear physics.

The centre of interest of the College was in condensed matter physics. Its members worked on a large variety of topics such as crystal growth, liquid crystals, vesicles and membranes, rheology of suspensions, quantum dissipation, superfluids and superconductors, magnetic phase transitions and frustration, anomalous Fermi liquids and conducting polymers.

The nuclear physicists continued work on gamma-ray induced Doppler broadening, the nuclear many body problem, and gamma ray emission.

## Scientific Activities in 1991

### Condensed matter physics

R. Bowley has studied the spin-polarisation in dilute  $^3\text{He}$ - $^4\text{He}$  mixtures. From NMR experiments he was able to determine the spin rotation parameters both via the Leggett-Rice effect and from spin echoes. He investigated also the Kosterlitz-Thouless transition in 2D superfluids and included the effect of vortex unbinding from a current above the critical temperature. Another topic were instabilities of crystal growth induced by temperature gradients.

Motivated by neutron experiments on magnetic insulators such as  $\text{SrCr}_8\text{Ga}_4\text{O}_{19}$  which have put into evidence extremely low ordering temperatures and, despite short coherence lengths, spin-wave like excitations, J. Chalker initiated a study of the Heisenberg anti-ferromagnet on a Kagomé lattice; P. Holdsworth and E. Shender participated in this project. They found a highly degenerate ground state but also order: the fluctuation entropy selects the subset of ground state configurations with the softest excitations. Chalker also worked on Anderson localization where he developed a new approach based on a finite size analysis of a mesoscopic sample connected to idealized leads. In the course of this work he found a simple model with long-range interactions which is solvable in arbitrary dimension.

G.W. Ford worked on dissipation in quantum mechanics. He reconsidered older problems of quantum electrodynamics from the standpoint of the radiation field being a heat bath. A related subject of interest was the spin-boson problem where he reformulated a calculation for Ohmic coupling in terms of a master equation. Together with R. Bateson, he also attempted to understand the influence of surface roughness on neutron scattering from ultrathin films.

B. Fourcade was concerned with the budding of vesicles. He investigated topological constraints at the moment of separation of two vesicles. He also collaborated in a study observing toroidal vesicles of genus larger than 1 and computed shape and fluctuations of genus-1 vesicles.

P. Holdsworth mainly worked on magnetic phenomena. In a collaboration with J. Chalker and E. Shender, he studied classical antiferromagnetic Heisenberg models on a Kagomé lattice. For more details, see the description of Chalker's work above. In another project, he worked on numerical simulation of the critical properties of 2D ferromagnets and compared them to neutron experiments on  $\text{Rb}_2\text{CrCl}_4$ . He found evidence for 2D finite-size effects related to the continuous symmetry of the problem. Finally, he collaborated in a neutron experiment on  $(\text{N}_2)_x\text{Ar}_{1-x}$  adsorbed on graphite which is a system of interest in the context of orientational glasses. Random Ar positions have been detected - but also some Ar-Ar correlations.

E. Kats was interested in the critical dynamics of orientation phase transitions in liquid crystals. Specifically, he proposed a procedure for including the effect of fluctuations of the order parameter on noncritical degrees of freedom. He worked out also the elastic properties of a two dimensional lattice of liquid cylinders.

C. Misbah is interested in the transition to chaos in directional solidification of liquid crystals. Together with A. Valance, he attempts to understand this transition with a minimum number of degrees of freedom. He also collaborates in a project aimed at classifying the broken symmetries accompanying the instabilities of interfaces far from equilibrium.

P. Nozières pursued work on the rheology of suspensions and on a possible analogy with electrostatics. He also investigated the instability of a solid-liquid interface under uniaxial constraints. While for a normal fluid the threshold of the Grinfeld instability is modified by the heat current, he was able to show that in superfluid  $^4\text{He}$  only the pure Grinfeld instability occurs while another one due to the heat current could only take place for temperature gradients beyond reach. Furthermore, he discussed the strange properties of a Fermi liquid with long-range attraction where the well-known Fermi-Dirac distribution is unstable. It turns out, however, that this possibility is unrealistic due to the superconducting ground state having a lower energy, the quasiparticle lifetime becoming short and due to the screening of the interaction.

Much of the time of P. Nozières was devoted to lecturing on the physics of strongly correlated Fermi liquids with relevance to high-temperature superconductors.

M.D. Nunez-Regueiro collaborated in a study of frustration effects near the magnetic-nonmagnetic transition in  $\text{RMn}_2$  compounds. Together with R. Ballou and C. Lacroix (CNRS) she produced evidence, based on a Hubbard-type approach, for complicated structures with coexisting magnetic and nonmagnetic sites. She made also progress in an investigation of the two impurity Kondo problem using a self consistent perturbation method.

J. Palmeri continued work initiated at CEN Saclay on the statistical mechanics of polymers and membranes. Collaborating with S. Leibler, he studied the influence of internal degrees of freedom on external properties of a membrane, and they found an extremely high sensitivity in a 1D chain model. Furthermore, he studied the statistical properties of tethered membranes. They can undergo a crumpling transition. He worked out a phase diagram implying the flatness of 2D membranes embedded in 3D space.

N. Schopohl investigated dissipation in a rotating texture of superfluid  $^3\text{He}$  in collaboration with G.E. Volovik (Landau Institute). They predicted Zener tunneling of spin-1/2 excitations as the main cause of dissipation and drew an analogy to the Unruh effect in particle physics. He pursued work with D. Waxman (Sussex) on the A-B interface in superfluid  $^3\text{He}$  and predicted the interface to be accompanied by a soliton-like quasiparticle distribution. In a further collaboration with a group from Hamburg, he developed a rather general theory for the upper critical field of high-field superconductors specifically improving over previous approaches in the correct treatment of the spatial variations of the order parameter.

E.F. Shender used the concept of magnetic two-level systems to explain anomalies in the static and dynamic magnetic properties of copper oxides. He considered also the instability of antiferromagnets with respect to exchange disorder. He finally participated in a study of classical antiferromagnetic on Kagomé lattices.

M. Uwaha was interested in problems related to crystal growth. In a study of aggregation growth in a diffusion field, he found a simple scaling behaviour of the growth velocity with the drift velocity for flow parallel to the growth direction while tangential flow with small velocity was found irrelevant. He worked on the scattering of a sound wave by parallel quantum steps and studied the fluctuation of a step under growth, which may be different from equilibrium. He predicted fluctuations to be suppressed in melting and enhanced in crystallization. Another project concerned the interaction and stability of step trains.

J. Voit pursued his effort to construct a field theory for the commensurate-incommensurate transition in interacting 1D fermion systems. He determined phase diagram and correlation functions of the half-filled extended Hubbard

model and obtained good agreement with available numerical data. A particularly interesting aspect of this work is the existence of a finite-coupling fixed point in this one-dimensional model. In collaboration with D. Baranowski (Bayreuth) he studied a 1D electron-libron model thought to describe polyaniline; they pointed out several important differences to the standard SSH-model. He finally developed a phenomenological description in terms of percolation models of the doping-dependent conductivity of polyacetylene. He was able to make predictions on the doping and temperature dependence which are currently being tested in a collaboration with N. Foxonnet and P. Bernier (Montpellier).

### Nuclear Physics

D. Janssen was concerned with the stopping behaviour of recoil atoms after evaporation of a gamma quantum. He set up a new method for solving the linearized Boltzmann equation describing this process. In another project, he collaborated with P. Schuck (ISN) on a self-consistent calculation of two-body correlations in interacting fermion systems. They obtain good agreement for the Lipkin model where an exact solution is available.

J. Jolie worked on Gamma-Ray Induced Doppler broadening, both experimentally and theoretically. He investigated intruder - normal state interactions in an experiment on  $^{113}\text{Cd}$ . This experiment also provided evidence for the existence of near-harmonic three-phonon states. A neutron capture experiment on Sm aimed at following the changes in the structure of certain excited states with increasing deformation of the Sm nucleus. In another experiment, he could resolve inconsistencies in the slowing down of Fe in  $\alpha$ - and  $\beta$ - $\text{Fe}_2\text{O}_3$  targets.

The theoretical work of J. Jolie was concentrated on modelling the stopping behaviour in the GRID technique. He collaborated with D. Janssen on the application of his linearized Boltzmann-equation formalism and with J. Keinonen and A. Kuronen on molecular dynamics simulations. The latter allow a more direct study of the interatomic potential. In a further project, he was able to describe the  $^{199}\text{Au}$  nucleus by a  $\text{U}^{\text{B}}(6)\times\text{U}^{\text{F}}(4)$  Bose-Fermi symmetric theory but the nucleus does not fulfill the conditions for a  $\text{U}(6/4)$  supersymmetry.

Secretary : J. Voit

## Nuclear and Fundamental Physics

### Members of the College

Börner H.G.	Williams A.
Faust H.R.	Balog K.
Fioni G.	Eder K.
Judge S.	El-Muzeini P.
Last J.	Gutsmiedl E.
Mampe W.	Jericha E.
Mayerhofer U.	Jungclaus A.
Pendlebury M.	Klora J.
Schreckenbach K.	Schorr F.
Ulbig S.	Tschernitz M.

### External members and guests

Abov Yu.	Kawai T.
Ageron P.	Keinonen J.
Altarev I.	Kessler E.
Asghar M.	Kilvington I.
Baldo-Ceolin M.	Krupchitski P.
Becvar F.	Lamoreaux S.
Blachot J.	Liaud P.
Bondarenko L.	Lieb P.
Casten R.	Morozov V.I.
Chibane Y.	Nistler W.
Danilyan G.	Oed A.
Denschlag H.	Oliver R.
Dewey S.	Pulglierin G.
Drexel W.	Ramsey N.
Dubbers D.	Rauch H.
Gähler R.	Smith K.
Geltenbort P.	Steyerl A.
Gobrecht K.	Van Klinken J.
Gönnenwein F.	Vatin-Perignon N.
Golub R.	Vivier G.
Green K.	Wagemans C.
Iaydjiev P.	Weirauch W.
Janssen D.	White D.
Jolie J.	Zeilinger A.

### Summary

All scheduled instruments of College 3 were running until the reactor shutdown at the beginning of the year. The requested removal of instruments to allow access to the beam tubes affects PN1, PN2, PN3/4, SN5, SN8 and the turbine, and the work has begun. The following experiments came to their end with the shutdown of the reactor:  $n\bar{n}$  which was hosted at the ILL for almost 5 years, and the scheduled instrument PN2 on the vertical beam tube. The magnet of PN2 will become part of a conversion electron facility at an external guide. With this decision almost twenty years of high resolution electron spectroscopy are now ended.

During the year considerable time was spent preparing for the future. The final layout and financing was studied to modernize the following facilities by increasing the available intensities with focussing options:

The Lohengrin spectrometer PN1 will get a new detection system including an energy- focussing magnet which increases the particle density up to a factor of 7. This project is largely financed by the external user groups.

The GAMS spectrometer will be upgraded. A two-axis bent crystal spectrometer considerably increases peak efficiency and resolution; the project is now part of the budget for the reconstruction of instruments.

A new PN7B facility is planned in the modernization program to provide cold neutrons of very high intensity by adding a new guide facing the horizontal cold source. This new position will have polarizing and focussing options and will be made available to users as a scheduled facility.

Work is being continued by external users to define two new major projects: The high intensity positron source proposed by K. Schreckenbach et al. and a strong fission product source proposed by the ISN, Grenoble, aimed to provide a radioactive heavy ion beam to the accelerator complex SARA situated nearby at the ISN.

During the year two members of College 3 left the institute: Steven Judge moved to Amersham International PLC, and Klaus Schreckenbach accepted a professorship at the Technical University of Munich, after almost 15 years of service to the ILL.

As new members of the college we welcome new instrument responsables: S. Ulbig is working at the GAMS spectrometer, G. Fioni at the Lohengrin facility, and U. Mayerhofer, who will take care of the BILL spectrometer.

### Scientific Highlights in 1991

**Electromagnetic interactions** in nuclei and the nuclear Hamiltonian were studied at the GAMS spectrometers PN3, the pair spectrometer PN4 and the conversion electron spectrometer PN2. This array of spectrometers permits the study of  $\gamma$ -ray and conversion electron transitions following neutron capture at internal target positions, and, at GAMS4 the determination of nuclear level lifetimes by analysing a  $\gamma$ -line shape broadened due to  $\gamma$ -induced Doppler-shifts. The data are subsequently compared with nuclear models. The centre of interest of this year's studies lay in the investigation of rare earth nuclei near the closed neutron shell  $N=82$ . The spectroscopy of  $^{144}\text{Nd}$  was examined on all the relevant instruments. 1200  $\gamma$ -transitions were assigned to this nucleus, 350 transitions were attributed to 61 levels located, which constitutes 77% of the total intensity. It is believed that the level scheme for this nucleus is now complete below 2.5 MeV excitation energy, comprising spins up to  $6\hbar$ . GRID data are under analysis and lifetime values for 11 transitions can be expected. Statistical models

and Monte Carlo methods have been used to determine the pattern of unobserved feeding of levels from the compound state (Göttingen, ILL).

$^{144}\text{Nd}$  is two neutrons away from the closed  $N=82$  shell, interpretations concern directly the behaviour of the  $2f$   $7/2$ -shell and the question whether mixed symmetry states in vibrational nuclei can be observed.

A complete study of  $^{155}\text{Gd}$  was performed including particle transfer reactions at Munich to test the Interacting Boson Approach including  $s$ ,  $p$ ,  $d$  and  $f$  bosons and to search for high lying  $M1$  states. Moreover, this nucleus was studied by a Munich-ILL-collaboration to deduce average feeding properties from Doppler profile analysis with the aim to develop reliable criteria for this approach.

The GRID method was used to investigate reduced  $E1$  transition properties from the lowest lying  $1^-$  and  $3^-$  states to the ground state band in samarium isotopes. As expected the values change drastically in going from  $^{148}\text{Sm}$  to  $^{152}\text{Sm}$ . This correlates with the well known transition from the spherical vibrational to strongly deformed rotational character of these isotopes. Furthermore statistical model approaches have been used to determine the unknown feeding of these levels (Göttingen, ILL).

On PN4 a Göttingen-Munich-ILL collaboration investigated level densities and  $\gamma$  strength functions in the Ni isotopes  $^{59,61,63,64}\text{Ni}$ . To reach  $^{64}\text{Ni}$  double  $n$ -capture from an isotopically enriched  $^{62}\text{Ni}$  target was performed.

Test measurements have been concentrated on the 2.7 MeV transition fed by the  $\beta$ -decay of  $^{24}\text{Na}$ . In contrast to  $\gamma$ -induced Doppler broadening the recoil distribution following  $\beta$ -decay is continuous. Theoretical studies have been undertaken to investigate whether the question of neutrino- $\beta$ -correlation can be approached by the GRID-method.

**Nuclear decay studies** including particle, cluster and fission decay continued on PN1, SN8 and H22D. On the latter beam position several  $(n_{\text{th}},p)$  reactions of importance to astrophysics have been investigated (Gent University).

A preliminary study of the  $^{14}\text{N}(n_{\text{th}},p)^{14}\text{C}$  reaction on air samples and using thin layers of polyimide ( $\text{C}_{22}\text{H}_{10}\text{O}_5\text{N}_2$ ) and adenine ( $\text{C}_5\text{H}_5\text{N}_5$ ) yielded cross-section values consistent with the literature value of 1.8 b.

Final results were obtained for  $^{35}\text{Cl}(n_{\text{th}},p)^{35}\text{S}$  and  $^{36}\text{Cl}(n_{\text{th}},p)^{36}\text{S}$ . For  $^{35}\text{Cl}(n_{\text{th}},p)^{35}\text{S}$  a reaction cross-section of  $(440 \pm 10)$  mb was determined, which is significantly lower than the evaluated value of  $(489 \pm 14)$  mb found in literature. For  $^{36}\text{Cl}(n_{\text{th}},p)^{36}\text{S}$ , a cross-section value of  $(46 \pm 2)$  mb was obtained which is one order of magnitude lower than the only other available value of  $(0.4 \pm 0.1)$  b measured at Dubna.

Finally, for  $^{50}\text{V}(n_{\text{th}},p)^{50}\text{Ti}$  a cross-section value of 0.8 mb was determined.

Also at H22D, the energy distribution and the emission probability of the Long Range Alpha particles emitted in the thermal neutron induced ternary fission of  $^{229}\text{Th}$  were determined for the first time. A (true) ternary  $\alpha$ -emission probability  $\text{LRA/B} = (2.17 \pm 0.10) \times 10^{-3}$  was obtained. This fairly high value is likely to be due to shell effects in the fission exit channel. For the ternary triton yield, a preliminary value  $t/B = (0.85 \pm 0.15) \times 10^{-4}$  was obtained for the emission probability, in agreement with semi-empirical expectations based on the fissility parameter  $Z^2/A$ .

Data evaluation continued on "Cosi Fan Tutte" data. A first comprehensive survey of mass-charge data on  $^{232}\text{U}$  was established by the Tübingen-Alger-Bordeaux Collaboration. Fig. 1 shows the results for the light fission wing. The same collaboration investigated proton odd-even-effects for the systems  $^{240}\text{Pu}$  and  $^{236}\text{U}$  towards low kinetic energies. The trend of stabilized odd even effects observed gives insights in which form intrinsic energy is stored near the scission point in the fragments.

On the Lohengrin spectrometer data collection for tripartition in the system  $^{243}\text{Am}$  was completed. Particles with atomic numbers up to that of Si have been detected (fig. 2). Concerning tripartition we now have reliable data sets for 2 systems:  $^{236}\text{U}$  and  $^{243}\text{Am}$ , showing that the mass-charge ratio of light particles follows closely the unchanged charge density value of the compound nucleus. (Bordeaux, Darmstadt, Tübingen, ILL).

Furthermore, for the first time a neutron deficient isotope, i.e.  $^{150}$  was detected. Odd-even-effects in both the proton and the neutron number are present and it has been demonstrated that light particle emission for heavier species than Be increases considerably when going from U to Am.

Data evaluation could be completed for far asymmetric fission of  $^{243}\text{Am}$ ,  $^{240}\text{Pu}$  and  $^{250}\text{Cf}$ , and three these are

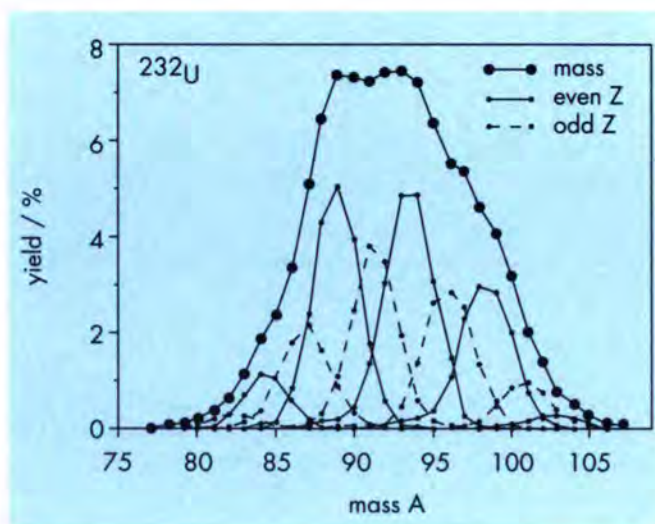

Fig. 1: Yield for fission products in the light wing from the reaction  $^{232}\text{U}(n,f)$ . The decomposition is made for the contributing nuclear charges, where strong odd-even effects are visible.

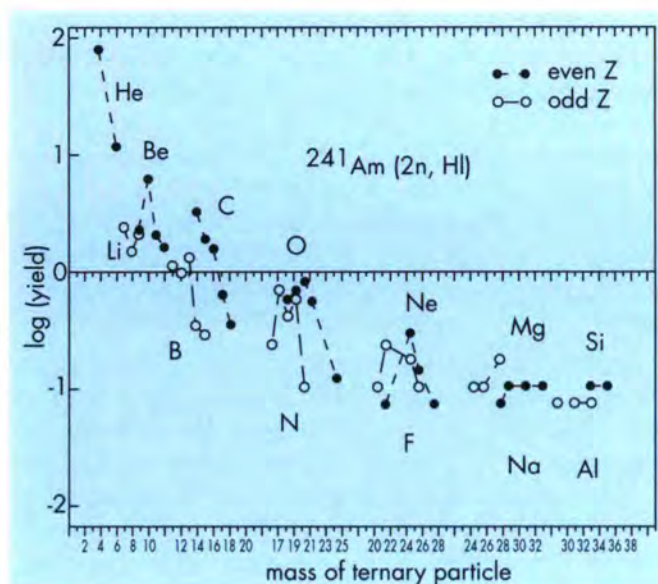

Fig. 2: Light particles from ternary fission of the compound system  $^{243}\text{Am}$ . Elements with atomic numbers up to that of Si are detected.  $\alpha$ -particle yield is normalized to 100.

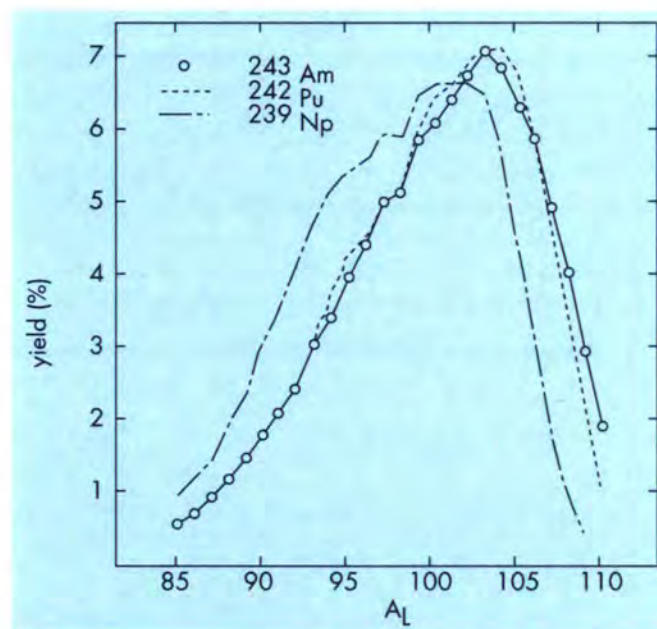

Fig. 3: Energy integrated mass distributions of light fission fragments from the reaction  $^{241}\text{Am}(2n, f)$  compared to  $^{237}\text{Np}(2n, f)$  and  $^{241}\text{Pu}(n, f)$ .

available on these data (Mainz, ILL). Together with the nucleus  $^{236}\text{U}$  we have now a reasonable data set for far asymmetric fission to be inspected for trends of proton and neutron odd-even effects, kinetic energies and fine structures in mass and charge distribution.

Data evaluation was completed for mass, charge and energy distribution for 'standard' fission of  $^{243}\text{Am}$ , comprising masses from  $A=85$  to  $A=110$  (Darmstadt, ILL).

Again it was confirmed, as we have seen earlier for  $^{239}\text{Np}$ , that adding protons to a compound system does not modify the mass distribution, apart from trivial effects (fig. 3).

Data evaluation was also completed for a cold fragmentation study in  $^{233}\text{U}(n, f)$  and a thesis is available (Darmstadt, ILL). It was confirmed that, as for the system  $^{236}\text{U}$  studied at Saclay the fragmentation in odd-odd nuclei is strongest when going to the very end of the available phase space at high kinetic energies. Fragments with an even number of neutrons and protons have probabilities for fragmentation which is much lower at the  $Q$ -value of the reaction. A study of yields at high kinetic energies shows the unexpected result that a correlation of yield to  $(V-Q)$  can only be established if the potential  $V$  between the fragments is calculated for spherical shapes and if the pairing energy in the  $Q$ -value is taken out (fig. 4). This observation invalidates any model which assumes that cold fragmentation proceeds via fragments in their groundstate.

**In nuclear  $\beta$ -decay** the investigation of  $Q\beta$ -values continued on the Lohengrin spectrometer (University Braunschweig). In the light fission product wing  $^{92}\text{Kr}$ ,  $^{106}\text{Nb}$  and  $^{108}\text{Mo}$  were investigated, in the heavy wing  $^{139}\text{I}$  and  $^{139}\text{Xe}$ . Beside the scientific interest in nuclear masses these measurements provided valuable data for decay heat calculations in nuclear reactors.

**In atomic physics** GRID studies continued to model slowing down processes of heavy ions, induced by  $\gamma$ -recoil (fig. 5). Theoretical interatomic potentials were tested against experimental data for KCl and NaCl compounds (Helsinki, ILL). For this purpose the recoil of  $^{36}\text{Cl}$  atoms produced via  $^{35}\text{Cl}(n, \gamma)^{36}\text{Cl}$  was used to establish a standard which is connected to the Doppler shift attenuation value in  $^{36}\text{S}(p, n)^{36}\text{Cl}$ . The lifetime deduced for the 1.9 MeV state in  $^{36}\text{Cl}$  was fixed to be  $\tau = (61 \pm 4)\text{fs}$ . Chlorine was slowed down in K and Na compounds and interatomic potentials were found for the Cl-Cl, Cl-Na and Cl-K interaction.

At considerably higher energies of the order of 1 MeV/amu energy loss of fission fragments in thin C, Ni and Au foils was examined on the Lohengrin spectrometer. Analytic functions dependent on fragment mass and energies have been fitted to the data (Tübingen, ILL).

At Lohengrin the data evaluation for heavy ions from strongly asymmetric fission confirmed the strong influence of ionisation probabilities of the Ne shell in high energetic ions (Mainz, ILL). Reaching the closed  $N=10$  electronic shell, the ionic charge distribution becomes strongly asymmetric, the reason being that the strongly bound  $10^{\text{th}}$  electron can hardly be taken off the ion (fig. 6). In the picture shown, the ionic charge distribution has been modelled by two gaussian distributions with different widths joining at  $Z-q=10$ .

**In particle and fundamental physics** we can report on the status of the neutron-antineutron oscillation experiment. The Heidelberg-ILL-Padova-Pavia collaboration searched

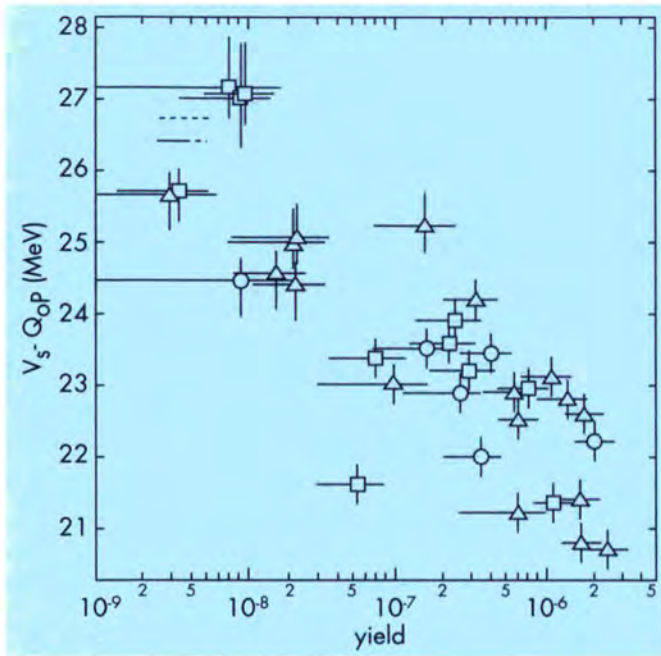

Fig. 4: Yields of fission fragments at 4.0 MeV total excitation energy are correlated to the difference of the available Q value of the reaction and a potential V describing the deformation of the fragments.

A correlation appears only if fission fragments are considered to be spherical at scission and if the pairing energies in the Q value are taken out. Here the correlation coefficient increases to  $K = 0.8$ , compared to  $K = 0.06$  which is obtained with the fragments observed to be born in fission in their groundstate deformation.

during two years of data taking for a rare process which is allowed in some Grand Unified Theories. During this period a total of approximately  $10^{18}$  neutrons travelled down the 80 m long, magnetically shielded pipe, before they passed through a thin, large area ( $1 \text{ m}^2$ ) carbon foil target. Here antineutrons created in flight would have annihilated and given rise to a pion shower with a total invariant mass of  $2m_n$ . The collaboration is now working on the final data analysis. So far there is no candidate for a clean neutron-antineutron annihilation event. Data taking with neutrons stopped in spring 1991 with the reactor shutdown. By then the previously existing limit on the oscillation period had been improved by roughly two orders of magnitude, which was the aim of the experiment.

Concerning the search for the electric dipole moment of the neutron a new instrument is being built (Sussex, RAL, ILL, Washington, Harvard) and progress with this is described in the section on Special Instruments (see the Instrument Operation Department). No new measurements of the EDM have been made at ILL since the last result  $d_n = -(3 \pm 2 \pm 4) \times 10^{-26} \text{ e cm}$  was published in 1990. In the meantime, the group from St. Petersburg has made some further measurements and their current result, when similarly rounded to single digits, is  $d_n = +(3 \pm 4 \pm 2) \times 10^{-26} \text{ e cm}$ . In each case the first error is the statistical one,

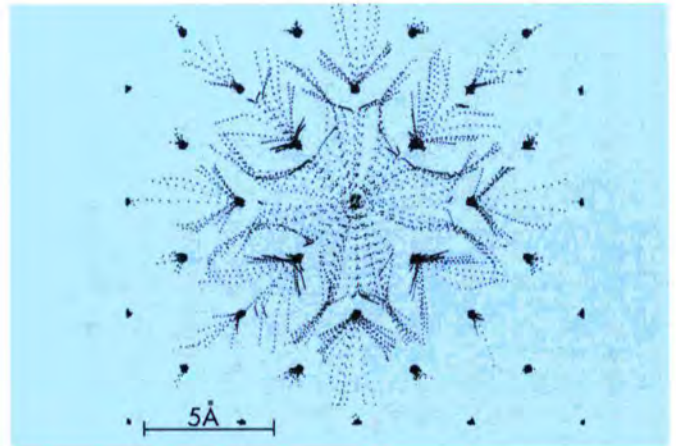

Fig. 5: Molecular dynamics simulation of the trajectories of recoiling and lattice atoms for the recoil of  $3 \times 10^4 \text{ m/s}$  Ti atoms in Ti-metal. This two-dimensional plot was obtained for the decay of a 3.26 MeV state in  $^{49}\text{Ti}$  which has a lifetime of 15.9 fs. The time difference between dots of the trajectories is  $\sim 10^{-15} \text{ s}$ . The figure is taken from A. Kuronen, *J. Phys. Condens. Matter* 3 (1991) 136.

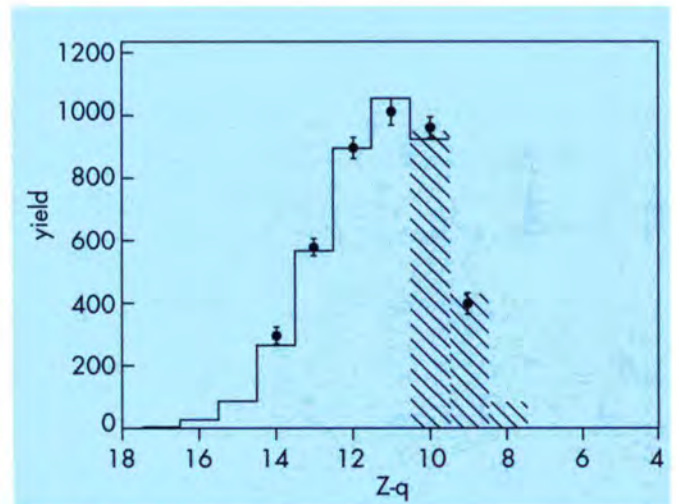

Fig. 6: Ionic charge distribution for  $^{77}\text{Ga}$  particles at 107 MeV kinetic energy. The hatched area distinguishes electron holes in the L-shell. Points represent measured values, the histogram is based on a simple model.

the second is the systematic error. The results from the two different experiments can be combined to a value of the neutron EDM of less than  $5 \times 10^{-26} \text{ e cm}$  with 90% confidence. Fig. 7 demonstrates the constant progress which has been made on the EDM value during the long years of experiments. Evolution of the theories of the EDM continue and there have been some interesting additions this year. In particular, calculations on the Weinberg multiple-Higgs mechanism now predict a value in the region of  $3 \times 10^{-27} \text{ e cm}$ . A similar value has been predicted from a class of QCD theories of the strong interaction.

On the BILL-spectrometer the search for a heavy neutrino, the existence of which was claimed by different groups based on studies with solid state detectors, was continued. The BILL-result is described in the blue box of the College 3 report. On the basis of the ILL data a 17 keV neutrino has to be excluded with 83% confidence (ILL, Munich).

On the PN7 beam position half of a reactor cycle was devoted to the search for parity violating effects in  $^{207}\text{Pb}(n,\gamma)^{208}\text{Pb}$  in continuation of an experiment scheduled at the end of 1990. The principle of this experiment was to measure tiny asymmetries in the emission pattern of the  $\gamma$ -rays with respect to the neutron spin. About half a dozen nuclei are known to give measurable parity violating effects of this kind but the lead reaction may be fundamentally different. All the other known cases can be explained in terms of s- and p-wave interference in compound nucleus formation. Where the effects are large enough to measure, the interference has been enhanced by a mechanism connected with the presence of p- or s-wave resonance states which are close in energy for the neutron-nucleus combination. Combining a neutron with  $^{207}\text{Pb}$  creates the doubly magic nucleus  $^{208}\text{Pb}$ . It seems that this may be a case of an alternative valence state, or single

particle state, interference mechanism which is indeed what was in mind when this pioneering spin rotation experiment on  $^{207}\text{Pb}$  was carried out at ILL by Heckel et al. in 1982. That this is the mechanism can be verified if the gamma-ray emission asymmetry and the spin rotation parameter are in the predicted ratio. Assuming the interpretation of the Heckel result to be correct the predicted gamma-ray asymmetry would be about  $5 \times 10^{-6}$ . The new experiment was carried out by a team of scientists from the Institute of Theoretical and Experimental Physics (ITEP) Moscow in collaboration with physicists from the ILL. As a result a new upper limit of  $|A_{\text{pb}}| \leq 5.8 \times 10^{-6}$  was established.

On the VCN interferometer, measurements were performed which show the phase shift of a cold neutron beam due to earth's gravity in a qualitative way. The experiment has revealed problems related to the mechanical design and the long term stability of the interferometer. The reactor shutdown period will be used to set up an active vibration isolating system for low frequencies ( $\sim 1$  Hz) (Vienna, Munich).

Also at the UCN source on level D, experiments continued on the storage of ultracold neutrons in a superthermal source (HMI Berlin and TU Munich). In earlier experiments it was found that the loss of ultracold neutrons in a liquid  $^4\text{He}$  filled bottle at 0.6 K is dominated by the properties of the wall material. In an attempt to develop improved wall characteristics, deuterated polystyrene was painted onto the walls of a stainless steel bottle. First measurements on the empty painted bottle at room temperature gave a UCN storage time of 62 s as compared to a theoretical prediction of 83 s. At low temperatures the predicted wall lifetime would be more than 1000s. However, when cooled down to 70 K the bottle lifetime deteriorated to 45 s. Cracking of the surface layer due to thermal stresses was suspected. Measurements on the deuterated polystyrene layer using the ILL special instrument EVA confirmed that the Fermi potential of the layer was 170 neV, but indicated that the average thickness was 400 Å which was too thin to prevent some UCN penetration.

A positive result can be reported from the  $\hbar/m_n$  experiment (PTB Braunschweig). Investigations on the penetration depths of neutrons in the Si crystal showed, that most neutrons are reflected in the first 60  $\mu\text{m}$  below the crystal surface, the volume which is used to determine  $\hbar/m_n$ . Other neutrons which penetrate deeper into the crystal lead to a constant background which spoils the contrast but does not lead to a systematic error. With these investigations it can be expected that the new value of  $\hbar/m_n$  will have an error of about 0.1 ppm.

**In geology**, studies have been continued into the calc-alkaline magmatism of the Andean mountain chain, with the accent being placed on the Jurassic to late Cretaceous intrusive rocks (ILL, Grenoble, Paris).

The Peruvian Coastal Batholith is made up of a series of igneous intrusions which form a broad linear feature running for over 4000 kms along the Pacific margin of the South

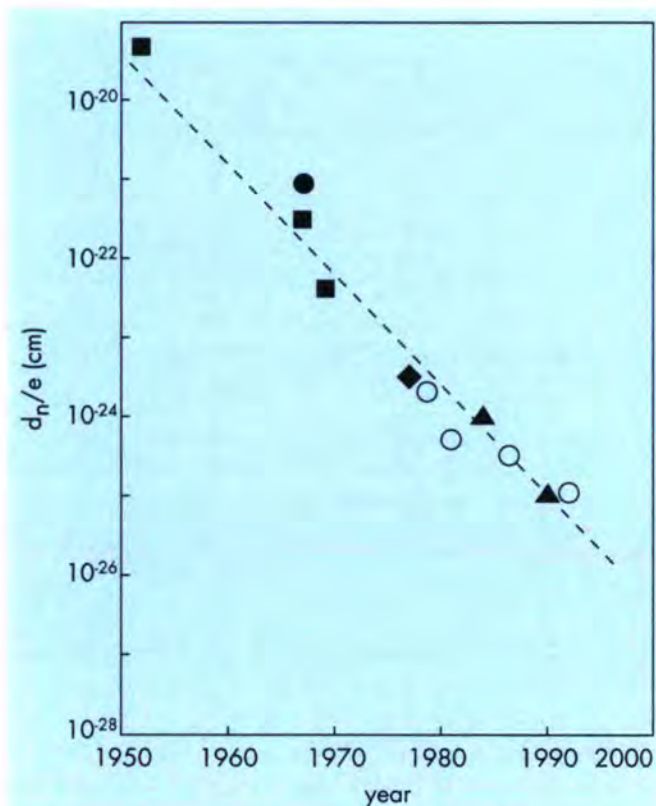

Fig 7: The upper limit for the size of the neutron electric dipole moment obtained from the more precise experiments. ■-ORNL-Harvard, ●-MIT-BNL, ◆-ORNL-Harvard-ILL-CENG-Sussex, ○-LNPI (St. Petersburg) ▲-Sussex-RAL-Washington-Harvard-ILL. These results have ruled out many theories relating to fundamental interactions and have strongly constrained others.

Fig. 8: a) Rare earth element yield values normalized to the yield values determined in chondritic meteorites.  
 b) Some trace elements plotted against the composition of mid-ocean ridge granites. Elements which have a crustal or lithophile affinity are plotted on the left, whilst elements with high field strengths are plotted towards the right.  
 c) Two high field strength elements plotted against each other.

American plate. The age of these intrusions range from 190 million years to 60 million years and generally the oldest intrusions lie in the south and they become progressively younger towards the north.

Rocks from a number of plutons in the southern part of this batholith have been studied and analyzed for the rare earth and trace elements, using in-beam and out-of-beam neutron activation analysis at the ILL. These data are presented in figs. 8a,b,c. and concern the plutons of Punta Coles (190 Ma), El Fiscale (60 Ma) and Quento (age undetermined).

The behaviour of the patterns in fig. 8a indicates that the source of the plutons has changed with time, from the Punta Coles to the Quento pluton, indicated by a steepening of the pattern, especially the light rare earth element. Furthermore it is deduced that the degree of melting has increased with time, shown by the overall increase of the values with respect to chondrite abundances.

From fig.8b it can be seen that the older pluton of Punta Coles shows relatively small enrichments of the lithophile elements and depletion of the high field strengths elements. From this we can conclude that the origin of this pluton is very close to the composition of the sub-continental lithosphere.

The plutons of El Fiscale and Quento show relatively large enrichments of lithophile elements and greater discrimination of high field strength elements indicative of a higher percentage of fusion.

Fig 8c shows two high field strength elements lying close to a regression line. The fact that the Zr/Hf ratio lies close to that of the primordial mantle ( $Zr/Hf > 32$ ) is a further good indication that these magmas have derived directly from the subcontinental lithosphere. A large variance of both data sets from the regression line would have led to the conclusion that there have been other processes, i.e. assimilation of the continental crust involved in the magmatic process. This is evidently not the case here.

Secretary: H.R. Faust

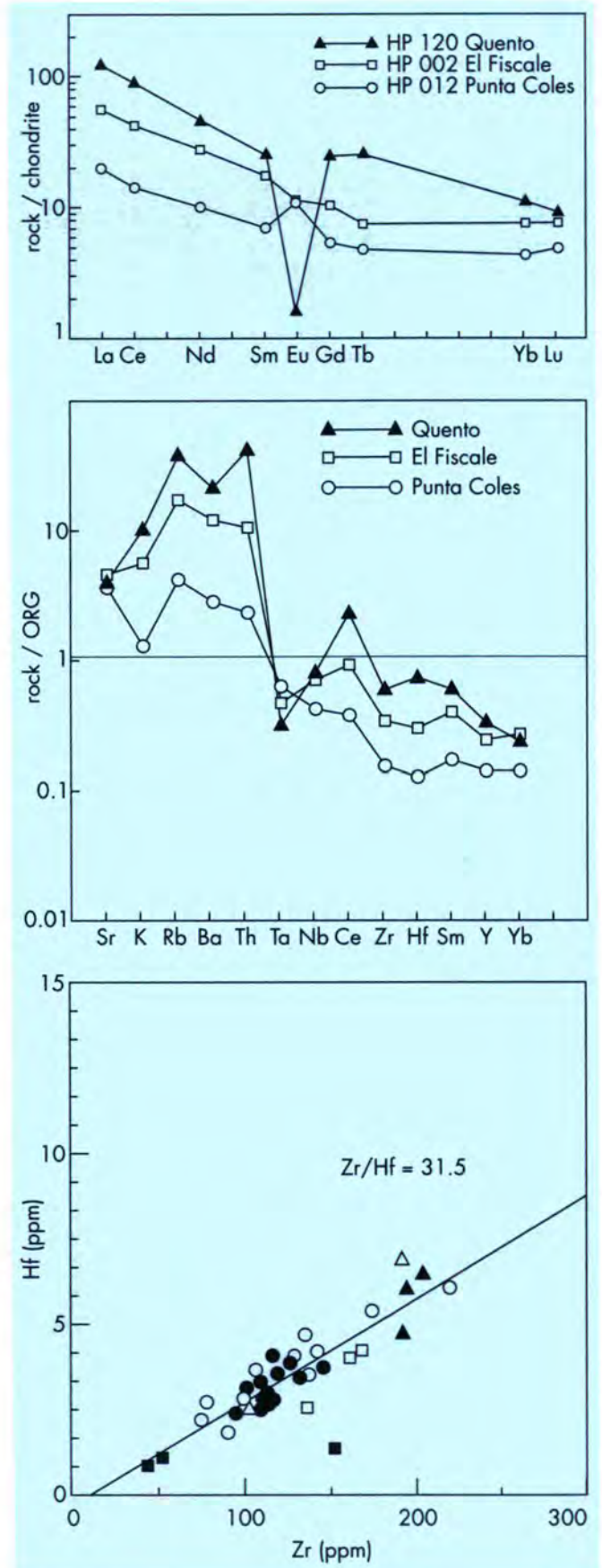

**Is there evidence for a 17 keV neutrino?**

**K. Schreckenbach**

In 1989 Simpson and Hime reported the discovery of a neutrino with a mass of 17 keV [1]. It was observed in the shape of the beta spectrum of the nuclear beta decay of  $^{35}\text{S}$  and occurred in a branch with about 1% intensity relative to the main branch with massless neutrinos. The experimental findings prompted a worldwide activity both in experiments and theories. In the following years Hime and Jelly [2] confirmed the 17 keV neutrino, while experimental results by several other groups questioned that observation. In parallel, particle physicists and cosmologists discussed possible models which could include a 17 keV neutrino in a consistent way.

A heavy and a light neutrino branch in the nuclear beta decay can be linked by the formalism of the mixing of neutrinos from different particle families, such as electron, muon and tau neutrinos. The neutrino produced in a weak interaction process is described as a superposition of two mass eigenstates with amplitudes of  $\sin\theta$  and  $\cos\theta$  respectively. The quantity  $\theta$  denotes the mixing angle. In the beta decay the square of amplitudes are observed, i. e. the heavy and light neutrinos are emitted with a probability of  $\sin^2\theta$  and  $\cos^2\theta$  respectively.

In an experiment measuring particle energies and momenta the mass eigenstates are observed. As an example the energy spectrum of the beta particles, which accompany the neutrino in the nuclear beta decay, samples the neutrino mass eigenstates, i.e. rest masses.

A superposition of two branches with different neutrino masses results in a total beta spectrum of the form:

$$dN/dE = \cos^2\theta \frac{dN(E, m_1)}{dE} + \sin^2\theta \frac{dN(E, m_2)}{dE},$$

where  $dN(E, m_i)/dE$  is the beta spectrum for massive neutrinos.

A convenient representation of beta spectra is the Kurie plot, which for  $m_\nu=0$  and an allowed beta decay has the form of a straight line with the maximum beta energy  $E_0$  as intercept. A massive neutrino branch would yield a distinctive deviation from a straight line below  $E = E_0 - m_\nu$  as shown in fig. 1 (kink). Experiments searching for such kinks are difficult since a small deviation from a straight line is not an obvious signature. A curvature of the Kurie plot of the data, due to unknown shape factors of the beta spectrum or due to the experimental resolution or efficiency function, could simulate or hide such a kink.

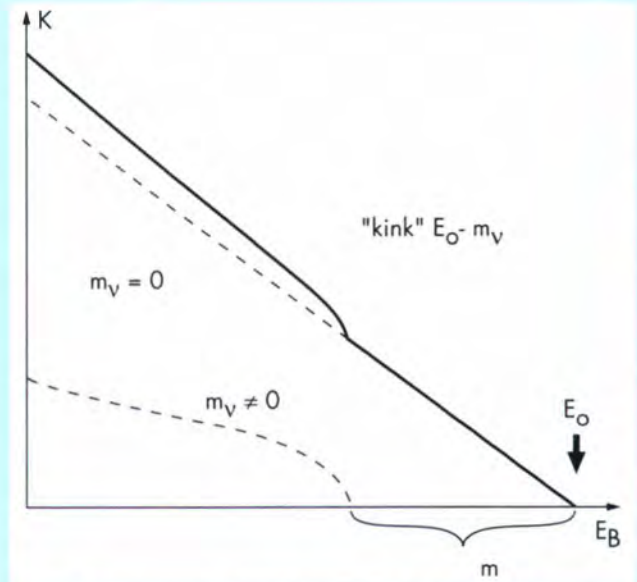

Fig. 1: Superposition of two beta decay branches with neutrino masses zero and  $m_\nu$ . The data are presented in the Kurie plot  $K \propto \sqrt{N/p^2 F}$ , where  $N$  is the electron momentum spectrum,  $p$  the electron momentum and  $F$  the Fermi function.

In the positive findings of refs. [1,2] the beta spectra were recorded by Si(Li) detectors. They respond to the absorption of mono-energetic electrons with an asymmetric pulse height distribution. The kink in those studies appeared clearly only, when the experimental spectra were unfolded from the response function of the detection system. On the other hand the response function was studied very carefully by the authors and the same effect was seen in isotopes of different end point energies and hence for different responses of the Si(Li) detectors. In  $^{35}\text{S}$  with  $E_0 = 167$  keV and in  $^{60}\text{Ni}$  with  $E_0 = 67$  keV the 17 keV neutrino branch was observed with  $\sin^2\theta = 0.0078(9)$  and  $.0099(22)$  respectively. The consistency of their results looks convincing.

The findings of Simpson, Hime and Jelly are very puzzling. From the recent LEP experiments we know that only three different neutrino-antineutrino pairs exist. This follows from the observed decay width of the  $Z^0$ : a fourth neutrino pair would open an additional decay channel for the  $Z^0$ , making its lifetime shorter and hence the decay width broader. Mixing of the observed amplitude with muon neutrinos is excluded by accelerator experiments. Thus within the known particles, only tau neutrinos remain as possible candidates for the 17 keV particle.

For such a heavy tau neutrino a cosmological bound has to be considered. From the big bang event, stable neutrinos of all kinds should remain in equal numbers in

the universe. For a neutrino species with mass 17 keV the present universe would have a much too high mass density, about 100 times more than the closure density. This is in contradiction to basic cosmological observations. Consequently, a 17 keV neutrino must decay sufficiently fast into a very light particle in order to overcome this bound. Within the Standard Model of the weak interaction the lifetime for such a neutrino would be much too long and exotic decay modes are required.

Glashow proposed a model where the massive neutrino decays to an as yet unknown majoron, which, as a singlet state, would not show up in the  $Z^0$  decay width [3]. But this model is faced by another cosmological constraint stemming from the evaluation of nuclear synthesis in the early universe. The primordial H to He abundance depends on the expansion rate, the temperature and the reaction rates in the first few minutes of the universe. Using in the evaluation the recent precise neutron life time value and the H to He ratio from present observations the number of weakly interacting particles during this early expansion of the universe is calculated to be 6 with an uncertainty of less than one unit. In contrast to the  $Z^0$  arguments, this value stems from the thermodynamics in the expansion of the universe and is not limited to neutrino pairs. The majoron would count as an additional weakly interacting particle and is hardly acceptable within modern models of the primordial synthesis.

From these few considerations it can already be seen how the existence of a 17 keV neutrino would change our present understanding of particle physics and cosmology. An experimental result of this consequence should be thoroughly tested.

Using the magnetic beta spectrometer BILL at the ILL we pioneered, already some years ago, the search for a possible massive neutrino in the shape of beta spectra [4]. The very high resolution of this spectrometer allows us to work at higher electron energies than in the experiments [1,2]. At 500 keV the BILL spectrometer has still 300 eV resolution to compare with typical 1000 eV for Si(Li) at 150 keV and the necessary corrections of the experimental spectra due to the response function are in general smaller for higher energies. Thus the kink from the 17 keV neutrino should show up directly in our raw data.

In a very recent ILL experiment on the 17 keV neutrino problem we have studied the beta decay of  $^{177}\text{Lu}$  [5]. The end point of the spectrum is 500 keV and the half life of the isotope 6.7 days. By neutron capture in  $^{176}\text{Lu}$  at the in-pile target site of the spectrometer ( $\phi_n = 3.3 \times 10^{14} \text{ n/cm}^2\text{s}$ ) a  $^{177}\text{Lu}$  source of 25 Ci was produced and the measurement performed during the

reactor shut down. The source remained at the target position during these measurements. The underlying background was determined in an only approximate way during a different reactor shutdown using a non-activated target.

Fig. 2 shows the result of the measurement in the Kurie representation. In addition to the overall intensity normalisation, the end point energy and the size of the hypothetical 17 keV neutrino branch, a further free parameter for the background level had to be introduced into the fit procedure. The optimum value for  $\sin^2\theta$  was found from the fit to be  $\sim 0.001$  and is compatible with there being no 17 keV neutrino branch. The average value from the experiments of Simpson, Hime and Jelly of 0.008 is excluded at a 83% confidence level by our data. The exclusion plot for the mass range investigated is shown in fig. 3.

The sensitivity of the experiment was not high enough to exclude (or confirm) the 17 keV neutrino branch with high confidence. The significant background level at the in-pile BILL target site even after the reactor shut-down was a serious drawback in the measurements. In a new experiment we intend to use the second BILL magnet with an external target which is activated by neutron capture elsewhere. Similar counting rates are expected with much better background conditions. Also the comparative measurement of a  $\beta^+$  and  $\beta^-$  spectrum in the decay of  $^{64}\text{Cu}$  could be tried, similar to our study [5]. A definite solution of the 17 keV puzzle seems, therefore, to be possible.

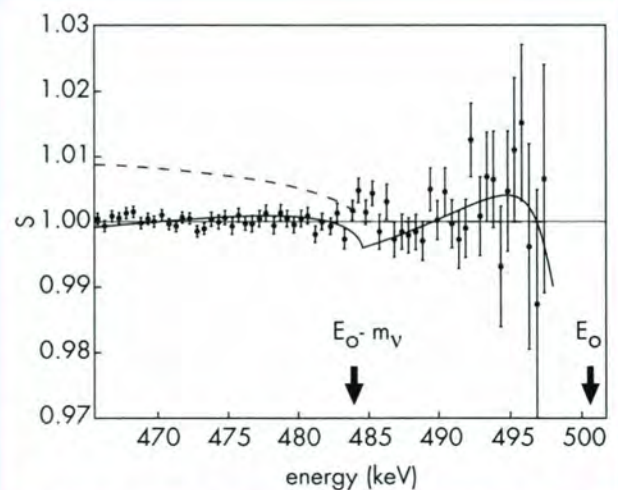

Fig. 2: Ratio  $S$  of the measured spectrum to the theoretical spectrum, for the case of no heavy neutrino admixture. The solid curve shows the expected shape for  $\sin^2\theta = 0.01$  and  $m_\nu = 17 \text{ keV}$ , with free parameters as described in the text. The dashed line illustrates the 1% branch if  $S$  is normalized to only the region above  $E_0 - m_\nu$ .

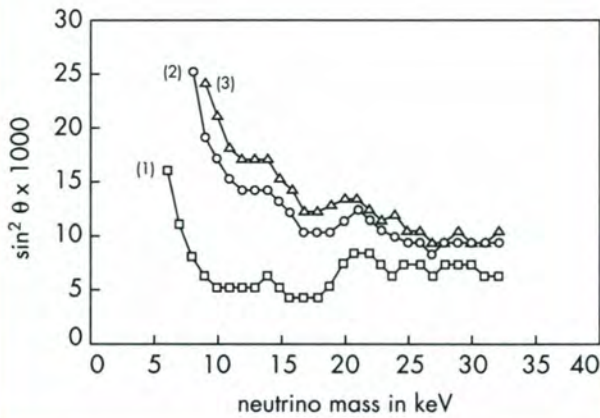

Fig. 3: Resulting exclusion plot for the coupling of a heavy neutrino, with a mass  $m_\nu$  in keV, to the electron neutrino with a  $1\sigma$  (1), 90% (2) and 95% (3) confidence level. The upper area

### References

- [1] J.J. Simpson and A. Hime, Phys. Rev. D39 (1989) 1825.
- [2] A. Heime and N.A. Jelly, Phys. Lett. B257 (1991) 441 and preprint Oxford University OUNP-91-21.
- [3] S.L. Glashow, Phys. Lett. B256 (1991) 255.
- [4] K. Schreckenbach, G. Colvin and F. von Feilitzsch, Phys. Lett. B129 (1983) 264.
- [5] S. Schönert, K. Schreckenbach, S. Neumaier and F. von Feilitzsch, "Workshop on the Standard Model of Electroweak Interaction", Valencia 1991 (World Scientific).

## Structural and Magnetic Excitations

### Members of the College

M. Alba	J.E. Lorenzo Diaz
K. Al Usta	J. Mesot
L. Andersen	A. Magerl
R. Bateson	W. Marshall
J. Bossy	J.L. Martinez
T. Brückel	T. Möller
R. Currat	A.P. Murani
S. Dakin	H. Mutka
B. Dorner	L. Needham
B. Fåk	W. Petry
B. Farago	S. Pouget
T. Fernandez	O. Schaerpf
E. Garcia Matres y Cortes	B. Schmid
A. Krimmel	H. Schober
J. Kulda	A. Severing
H.J. Lauter	J. Trampenau
J.F. Legrand	M. Vrtis
A. Lied	C.M.E. Zeyen

### General Summary

The scientific work in College IV was very intense during the few reactor cycles in 1991 until the reactor was stopped for its complete refurbishment. The high overdemand of inelastic spectrometers in the spring Scientific Council has demonstrated the ever growing interest for this type of experimental work. Many subjects were concerned as different as high  $T_c$  superconductors, phase transition in low dimensional systems, lattice dynamics of soft materials and crystal field effects in rare earth compounds. The "Users' Meeting" in Uriage has revealed a pronounced interest of the scientific community for future instruments such as D5B or IN5TF. We may hope that the college IV will have the means in the future to face the growing needs for dynamical studies with an even higher level of competence.

In spite of all the disturbances involved by the shutdown of the reactor, the scientific life stayed very active throughout the year 1991. It has benefitted from the success of the "XXI<sup>th</sup> European Symposium on the dynamical properties of Solids" held in Autrans (France). This European Research Conference was organized by B. Dorner, R. Currat and H. Schober. The programme was covering most of the college IV subjects of research that will be detailed in the following paragraphs.

### Scientific Trends and Highlights in 1991

#### Lattice Dynamics and Structural Phase Transitions

This is a very active domain where the work can be divided into three main categories: phonon anomalies in incommensurate materials or in superconductors and dynamics of model systems.

### Sapphire

Complete sets of dispersion curves (Fig. 1) have been determined for several high symmetry directions of Sapphire ( $\text{Al}_2\text{O}_3$ ). The dispersion curves were investigated in the energy range up to 30 THz using the instrument IN1B, three-axis spectrometer viewing the hot source. The experiments have been accompanied by shell model calculations that successfully reproduce the measured frequencies and most of the observed intensities. The above lattice dynamical investigation in connection with a thorough study of the dielectric constants has led to an improved understanding of the binding forces in Sapphire. In particular, there is clear evidence for a rather complex screening mechanism involving the oxygen orbitals [1]. Based on the validity of shell models for the description of the lattice dynamics of Sapphire, values of approximately  $1.9 \pm 0.2 e$  and  $1.8 \pm 0.2 \text{ \AA}^3$  have been derived for the ionic charge and polarizability of the oxygen ion.

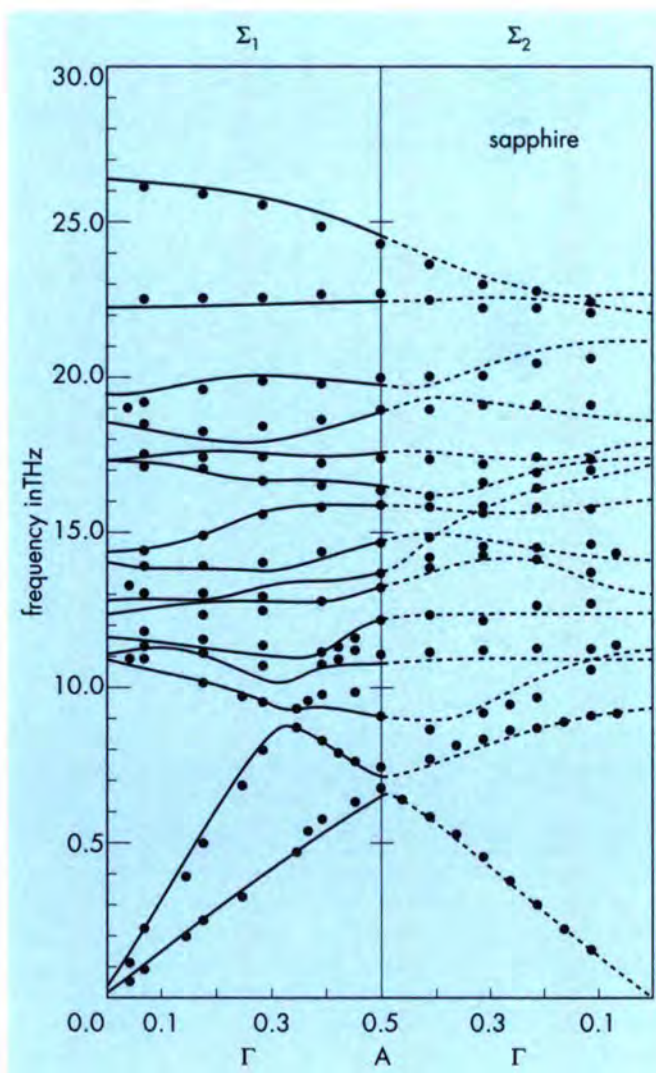

Fig. 1: Dispersion curves of Sapphire ( $\text{Al}_2\text{O}_3$ ) at 25 K for the  $\Gamma$ -A direction. The experimental frequencies are described by a 7 parameter shell model. The two irreducible representations have been unfolded for clarity.

## Niobium

The frequency and life time of acoustic phonons in Nb were measured by high resolution triple-axis spectroscopy on IN14. Quantitative information was extracted on the  $\mathbf{Q}$  and phonon-polarization dependence of the electron-phonon interaction over a temperature range spanning the superconducting temperature [2]. For phonons with energies  $\hbar\omega$  less than the zero temperature gap  $2\Delta(T=0)$ , a sudden increase in damping is expected at a temperature  $T^*$ , defined by  $2\Delta(T^*) = \hbar\omega$ , because the phonon can excite quasiparticles across the gap. Clear evidence of such a sudden increase is seen (Fig. 2) in Niobium ( $T_C = 9.2$  K,  $2\Delta(T=0) = 3.1 \pm 0.1$  meV) where  $T^*$  is equal to 8 K for a phonon energy  $\hbar\omega$  of 2.64 meV. The behaviour of the transverse modes agrees with a simple calculation based on BCS theory of superconductivity [3], but the damping of a longitudinal mode is unexpectedly severe. This unusual behaviour may arise because the longitudinal phonon wavelength (8 nm) is comparable to the size of the Cooper pairs in Niobium ( $\xi_0 = 40$  nm).

## pTS Polymer

Some substituted diacetylene compounds ( $R-C\equiv C-C\equiv C-R'$ ) may undergo a progressive polymerisation in the crystalline state. This gives an opportunity to obtain large size crystals of conjugated polymer. pTS is the most extensively studied member of the substituted diacetylene family, with  $R = R' = CH_3-C_6H_4-SO_2-OCH_2$ . The monomer (mono-pTS) and the polymer crystal (poly-pTS) are isomorphous at room temperature ( $P2_1/c$ ,  $Z = 2$ ) and both exhibit a structural phase transition at low temperature. These instabilities are associated with motions of the polar side groups R. An incommensurate phase ( $q_s = 1/2a^* \pm \delta b^*$ ) exists in the mono-pTS crystal until a lock-in phase transition takes place, yielding a doubling of the cell parameter  $a$  ( $P2_1/c$ ,  $Z = 4$ ). On the contrary, this cell doubling proceeds directly in the poly-pTS crystal. Inelastic neutron scattering study of the structural transition of mono-pTS and poly-pTS reveals that the dynamical behaviour is almost not affected by the polymerisation. The dynamics is intermediate between displacive and order-disorder. It is more displacive in the polymerized state (poly-pTS), with a soft mode condensing directly at a commensurate wavevector [4]. On approaching the transition from the high temperature phase, an overdamped soft mode and the growing of a central peak is observed (Fig. 3). The  $\mathbf{Q}$ -space extension of the central peak is anisotropic, consistent with the dispersion law of the soft mode, with stronger correlations along  $\mathbf{b}$  (direction of polymer chains):  $\xi_b \sim 2\xi_a$ . It was also noted that the critical scattering in the polymerized compound is well centred on the superlattice position.

## Low dimensional systems

Concerning this field of research, there is a noticeable amount of new results on the quantum gap in one dimensional antiferromagnets with integer spins, the Haldane gap conjecture presented in last year's report. This year, we shall illustrate the physics of low dimensional systems with other examples taken from charge density wave compounds and singlet groundstate systems.

## Phonon softening in NbSe<sub>2</sub>-2H

NbSe<sub>2</sub>-2H belongs to the transition metal chalcogenides [5]. These metallic quasi-two-dimensional compounds are known to undergo a charge density wave (CDW) transition. This transition originates from quasi-cylindrical Fermi surface pockets of d character, which favour nesting conditions. The transition may follow a displacive or a simple order-disorder scheme, depending on the strength of the electron-phonon coupling. It is therefore important to examine if the CDW transition is brought about by the condensation of a soft mode. Longitudinal phonon softening was investigated in NbSe<sub>2</sub>-2H at wavevector  $\mathbf{Q}=(a^*/3,0,0)$  on the IN8 and IN12 three-axis spectrometers. At room temperature, two branches belonging to the  $\Sigma_1$  symmetry are observed at  $\hbar\omega_1 = 10$  meV and  $\hbar\omega_2 = 5$  meV. The energy of the lower branch starts to decrease only when the temperature is lowered below 100 K down to  $T_D = 33$  K, the temperature of the structural phase transition. The softening

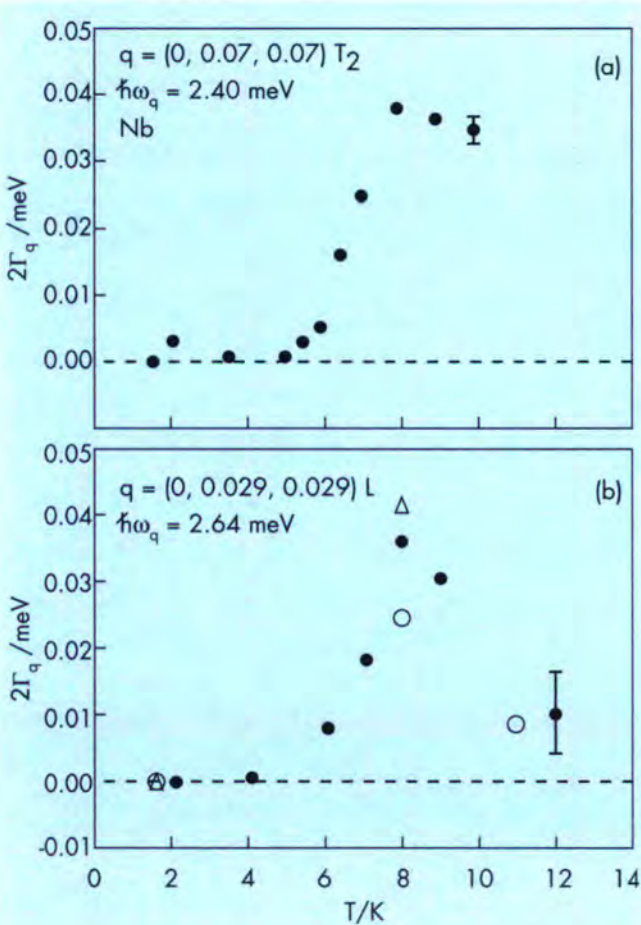

Fig. 2: Temperature dependence of the linewidth  $2\Gamma_q$  of phonons along  $[0\zeta\zeta]$ .

(a) the transverse mode with ( $\zeta = 0.07$ ,  $|\mathbf{Q}| = 1.88$  nm<sup>-1</sup>) from the  $T_2$  branch measured with PG (002) as monochromator and analyzer,

(b) the longitudinal mode with ( $\zeta = 0.029$ ,  $|\mathbf{Q}| = 0.78$  nm<sup>-1</sup>) measured with different monochromator/analyzer combinations.

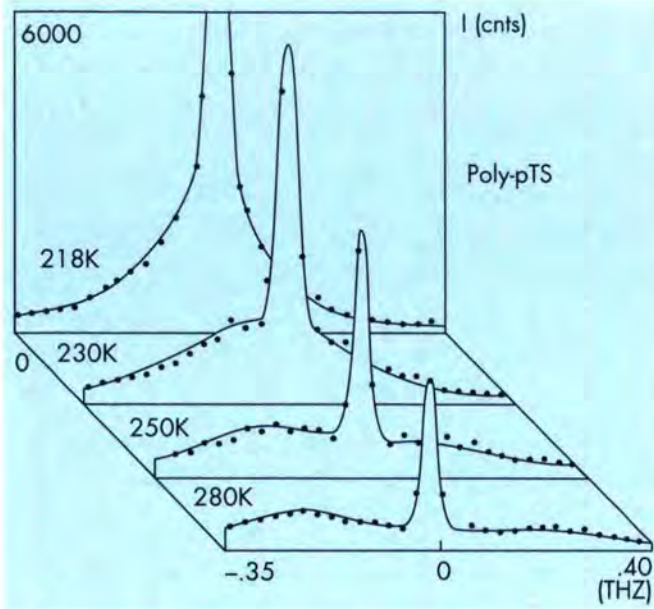

Fig. 3: Inelastic neutron scattering spectra in the high temperature phase of poly-pTS measured at  $Q = (2.5, 1, 0)$  with  $K_i = 1.54 \text{ \AA}^{-1}$ . A soft mode and a central peak are observed when approaching the transition temperature  $T_S = 218 \text{ K}$ .

is complete within experimental uncertainty. The observed splitting of the two  $\Sigma_1$  modes agrees with a lattice dynamics calculation based on a microscopic model taking into account the electron-phonon interaction. Nevertheless, there are still open questions on the low values of the  $\Sigma_1$  and  $\Sigma_2$  modes at room temperature and on the departure of their temperature dependence from the mean field behavior.

### Mode renormalization in $(\text{NbSe}_4)_3\text{I}$

Transition metal tetrachalcogenides have a marked 1D metallic character and generally exhibit metal-insulator transitions with the formation of incommensurate charge-density-waves [6]. Structurally, they are made up of  $\text{MX}_4$ -chains separated by strands of iodine atoms. The quasi-1D character of the compounds is also evidenced by the presence of low-lying transverse modes propagating perpendicular to the chains and polarized along the chains.  $(\text{NbSe}_4)_3\text{I}$  (and isomorphous  $(\text{TaSe}_4)_3\text{I}$ ) belong to this structural class, but unlike other compounds in the same class, such as  $(\text{NbSe}_4)_2\text{I}$  and  $(\text{NbSe}_4)_{10}\text{I}_3$ , which become Peierls insulators below room temperature,  $(\text{NbSe}_4)_3\text{I}$  exhibits a ferrodistorptive phase transition from  $P4/mnc$  to  $P4_2/c$ . Ultrasonic measurements in the distorted phase have detected a large renormalization of the sound velocity associated with the low-lying transverse modes, from 140 m/s at room temperature to 420 m/s at 10 K. Inelastic scattering experiments [7] on IN6 and IN12 with  $(\text{NbSe}_4)_3\text{I}$  powder and single-crystal samples, revealed that the mode-renormalization was not limited to long wavelengths but affected the entire dispersion sheet. Figure 4 shows the good consistency between the time-of-flight and three axis data, in spite of the coherent character of the scatterers. The flat,

Einstein-like  $\text{TA}_Z$  branch at 300 K gives rise to a hump around 0.5 meV in the Generalized Density of States (GDOS) spectrum, and the transition to a normal Debye-like behaviour at 100 K is seen with both techniques. The same type of flat, low-frequency branch is present in  $(\text{TaSe}_4)_2\text{I}$  at all temperatures and it is believed to be at the origin of the observed specific heat and thermal conductivity anomalies in the 1-2 K range.

### Phase transition in singlet groundstate system $\text{CsFeBr}_3$

The singlet groundstate systems of the type  $\text{AFeX}_3$  ( $A = \text{Cs, Rb, X} = \text{Cl, Br}$ ) are known to be prototype systems for 1-D-behaviour because their structure is built from chains of face sharing  $\text{FeX}_3$  octahedra being separated by the A-ions.  $\text{CsFeBr}_3$  (crystal structure  $P6_3/mmc$ ) has been studied by inelastic neutron scattering [8]. The  $\text{Fe}^{2+}$ -ion with the effective spin  $S = 1$  has a singlet groundstate ( $m = 0$ ) while the first excited state is a doublet ( $m = \pm 1$ ). This doublet undergoes a Zeeman splitting in an external magnetic field  $H_{\text{ex}}^z$  applied along the z-axis. An experimental intensity distribution in reciprocal space for various magnetic fields was derived from inelastic

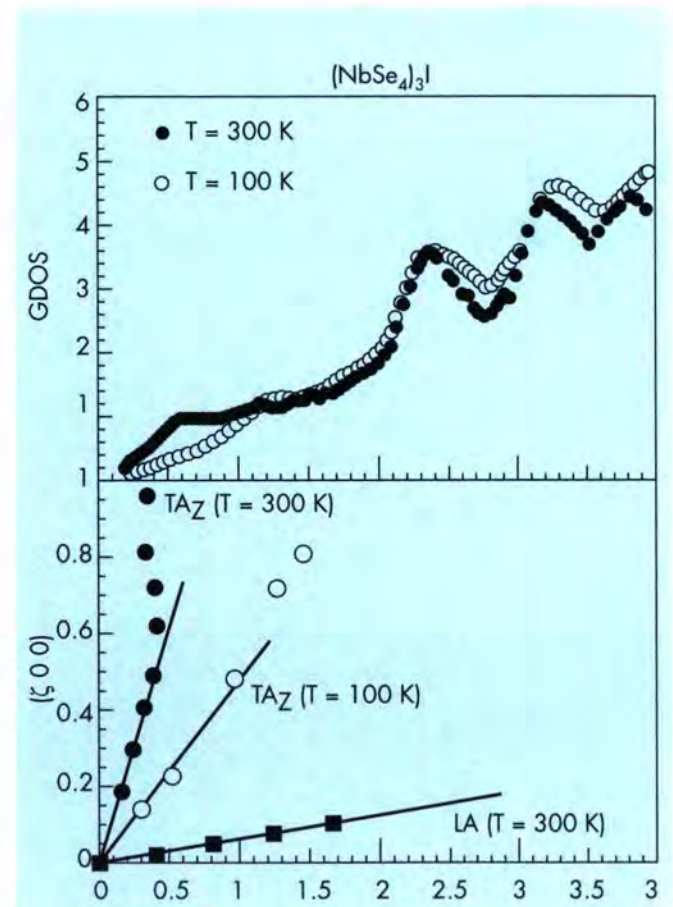

Fig. 4: Low lying branches in  $(\text{NbSe}_4)_3\text{I}$ : (Top) IN6 generalized density of states data at 300K and 100K; (Bottom) the corresponding acoustic dispersion curves measured on IN12 (note that axes are in reverse order [Energy transfer on X-axis,  $Q$  on vertical axis] compared to normal plots).

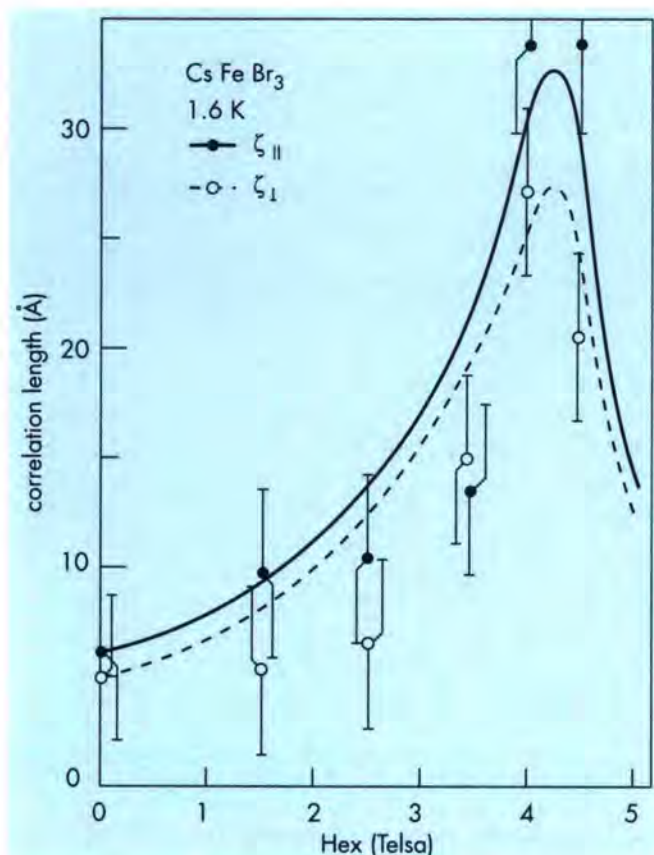

Fig. 5: Correlation lengths in  $\text{CsFeBr}_3$  as a function of applied magnetic field: Full and open symbols represent experimental observations parallel and perpendicular to the chains, respectively. The calculated values are given by the full (parallel) and the dashed (perpendicular) lines.

experiments. Correlation lengths in real space are deduced from these intensity distributions (Fig. 5). In parallel, newly derived values for exchange and anisotropy were used to calculate intensities and in turn correlation lengths [9]. Experimental and calculated correlation lengths both increase with increasing external magnetic field  $H_{\text{ex}}^z$  as one would expect for precursors approaching a phase transformation. But near the phase transition at  $H_{\text{ex}}^z = 4.1$  Tesla, the correlation lengths do not diverge. They exhibit a flat maximum around 4.1 Tesla and decrease again at higher fields. Looking at the appearing Bragg intensity [8], one can conclude that the phase transition is nearly of second order. However, the invisibility of critical phenomena may lead to the conclusion that it could be a first order transition.

## Magnetism

As for lattice dynamics, recent work in magnetism can be separated in three major domains: superconductors, heavy fermion systems, and critical dynamics in model compounds. In the past year, progress was made in these three domains but in this annual report we shall focus on examples drawn from the first two.

## Low energy magnetic response in $\text{UBe}_{13}$

The most notable characteristic of heavy fermion systems is their high value of  $\gamma$ , the coefficient of their electronic specific heat at low temperature (e.g., 1100 mJ/(mol K<sup>2</sup>) for  $\text{UBe}_{13}$ ). Simultaneously, the magnetic susceptibility is also large at low temperature, revealing magnetic fluctuations that may be the origin of the high specific heat. If the system does not order magnetically, the spectrum of these fluctuations is purely relaxational in form and can be characterized in simple systems by a unique inverse relaxational time  $\Gamma(\mathbf{Q})$ , which is inversely proportional to the coefficient  $\gamma$ . In Uranium-based heavy fermions like  $\text{UPt}_3$  or  $\text{UBe}_{13}$ , the situation is more complex and the magnetic response splits on two time scales (or energy scales in neutron scattering experiments), each with its own  $\mathbf{Q}$ -dependence. The low frequency response of  $\text{UBe}_{13}$  was examined on IN6 on polycrystalline samples. A quasi elastic response has been found, with a characteristic linewidth of 1.5 meV at  $T > 1$  K (Fig. 6). This response is almost independent of the  $\mathbf{Q}$  vector and it narrows and increases in intensity in the superconducting state below 0.6 K [10]. Its temperature dependence scales with the one of the bulk magnetic susceptibility. The strength of the response corresponds with 100% of the bulk susceptibility above 1.5 K and 60% below where a broader response (linewidth of 13 meV [11]) appears. The total response function for  $\text{UBe}_{13}$  thus contains two components, one with a linewidth of 1.5 meV and the other with a linewidth of 13 meV and the weight is approximately evenly divided between the two. These magnetic fluctuations, existing on two different energy scales like in  $\text{UPt}_3$ , differ from the behavior observed in other heavy fermions, like Ce-based systems, and are not yet fully understood.

## Spin fluctuations in Fe-doped or Co-doped $\text{YBa}_2\text{Cu}_3\text{O}_{6+x}$

The region of the phase diagram of  $\text{YBa}_2\text{Cu}_3\text{O}_{6+x}$  where superconductivity takes over antiferromagnetism could be of crucial interest in understanding the mechanism of superconductivity. Recent neutron and NMR experiments have shown the existence of antiferromagnetic fluctuations of the Cu spins in superconducting samples. The study of Iron-doped or Cobalt-doped superconducting compounds also can yield information about the Cu states. Inelastic neutron scattering studies were performed on IN6 on sample  $\text{YBa}_2(\text{Cu}_{1-x}\text{Co}_x)_3\text{O}_7$  with  $x = 0.06$  (for this concentration, Co occupies only the  $\text{Cu}_1$  site). The study of the Co spin dynamics [12] reveals the same kind of anomalous features already seen in Fe-doped compounds: a small effective moment at high temperature and a strong increase of this effective value at low temperature below 100 K. The reduction of the effective moment at high temperature has been interpreted by a coupling of the Fe spins with conduction holes. The high increase of the moment at low temperature could therefore suggest a suppression of this coupling due to the formation of Cu singlet pairs. In the present results, such pairing would take place well above the superconducting transition. This picture has been confirmed

by the disappearance of this effect in a non superconducting deoxygenated Fe-doped compound. However, for Co-doped non superconducting samples, the Co spins exhibit the same anomalous increase of the moment at low temperature. The coexistence of these dynamic Co spins with antiferromagnetic sheets remains to be understood.

### Incommensurate magnetic Correlations in $\text{La}_{1.8}\text{Sr}_{0.2}\text{NiO}_4$

Recent experiments at Risø National Laboratory and ILL have determined the wavevectors of the 2D incommensurate magnetic fluctuations in highly doped Lanthanum cuprate crystals  $\text{La}_{2-x}\text{Sr}_x\text{CuO}_4$ [13]. Using a square lattice notation in which the antiferromagnetic order for pure  $\text{La}_2\text{CuO}_4$  is at the position  $\mathbf{Q} = (1,1)$ , the incommensurate peaks are at the wavevectors  $\mathbf{Q} = (1,1\pm\delta)$  and  $(1\pm\delta,1)$ . With  $|\delta| = 0.14\pm 0.02$  for  $x = 0.075$  and  $|\delta| = 0.24\pm 0.01$  for  $x = 0.14$ . The scattering is reminiscent of the incommensurate itinerant antiferromagnet chromium and is a reflection of nesting in the Fermi surface. The magnetic fluctuations correspond to strongly nested wavevectors in the Fermi surface that give rise to peaks in the magnetic susceptibility  $\chi(\mathbf{Q})$ . The figure 7 shows a similar measurement on  $\text{La}_{1.8}\text{Sr}_{0.2}\text{NiO}_4$ [14] a compound with the same structure as  $\text{La}_{2-x}\text{Sr}_x\text{CuO}_4$ . Both  $\text{La}_2\text{CuO}_4$  and  $\text{La}_2\text{NiO}_4$  are antiferromagnetic insulators with similar magnetic structures. The only difference is the direction in which the ordered moments point. On doping, the cuprate becomes metallic (and superconducting), while the nickelate remains insulating up to high doping levels ( $x=1$ ). Incommensurate correlations are also seen in the nickelate. However, the wavevectors of the strongest scattering are different  $\mathbf{Q} = (1\pm\delta_1, 1\pm\delta_1)$  and  $(1\pm\delta_1, 1\pm\delta_2)$  with  $\delta_1 = -\delta_2 = 0.16$  for  $x = 0.2$ . The peaks are rotated  $45^\circ$  with respect to the cuprate. Despite the striking similarity, the mechanism behind the phenomenon may be different in the two systems.

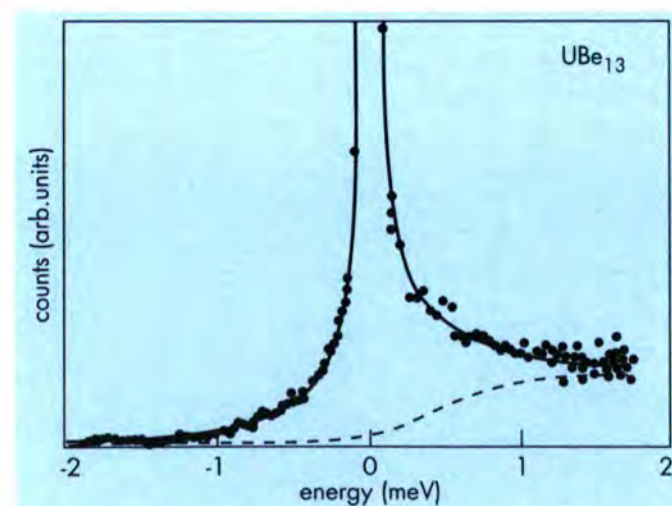

Fig. 6: Representative  $S(\mathbf{Q}, \omega)$  spectra for  $\text{UBe}_{13}$  at  $T = 1.5$  K and  $\mathbf{Q} = 0.95 \text{ \AA}^{-1}$ . The solid line is a fit to the total spectrum, whereas the dashed line shows the form of the magnetic response function.

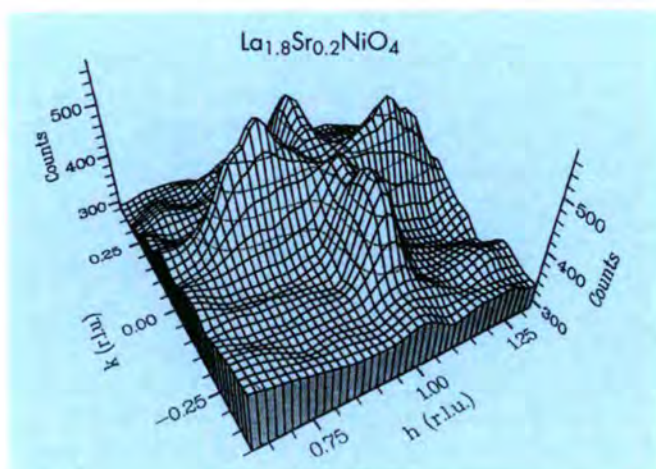

Fig. 7: The scattered intensity from  $\text{La}_{1.8}\text{Sr}_{0.2}\text{NiO}_4$  in the  $(hkl/2)$  plane around the  $(1,0,1/2)$  position for  $T = 2$  K measured on IN12. The spectrometer was set at the elastic  $\hbar\omega = 0$  position and collected neutrons within an energy window of width  $\Delta\hbar\omega = 82 \mu\text{eV}$ .

Among many possible models, the observed peaks in the nickelate may come from correlations in the positions of antiferromagnetic domain boundaries.

### References

- [1] H. Schober, D. Strauch, B. Dorner, to be published
- [2] A.T. Boothroyd, W.G. Stirling, R. Currat, N.R. Bernhoeft, D.McK. Paul, S.I. Shilub, ICNS'91 (Oxford 27-30 august 1991) [Physica B (to be published)].
- [3] V.M. Bobetic, Phys. Rev. 136 (1964) 1535.
- [4] J. Even, H. Cailleau, B. Toudic, M. Bertault, F. Moussa, R. Currat, ICNS'91 (Oxford 27-30 august 1991) [Physica B (to be published)].
- [5] C. Ayache, R. Currat, P. Molinié, (to be published).
- [6] P. Monceau, L. Bernard, R. Currat, F. Levy and J. Rouxel, Physica B136 (1986) 352
- [7] J.E. Lorenzo, R. Currat, P. Monceau, J.A. Dianoux and F. Levy, to be published
- [8] B. Dorner, D. Visser, M. Steiner, Z. Phys. B Condensed Matter 81, 75(1990)
- [9] B. Schmid, B. Dorner, D. Visser, M. Steiner, Z Phys. B. (in press)
- [10] S.M. Shapiro, G.H. Lander, C. Vettier, J. Dianoux, Submitted to Phys. Rev. B
- [11] A.I. Goldman, S.M. Shapiro, G. Shirane, J.L. Smith, Z. Fisk, Phys. Rev. B 33 (86) 1627
- [12] C. Bellouard, M. Hennion, I. Mirebeau, A.J. Dianoux, V. Caignaert, ICM91 (Edinburgh, 2-6 september 1991) (to be published)
- [13] S.W. Cheong, G. Aeppli, T.E. Mason, H. Mook, S.M. Hayden, P.C. Canfield, Z. Fisk, K.N. Clausen and J.L. Martinez, Phys. Rev. Lett. 67, 1791 (1991).
- [14] J. Brown, S.M. Hayden, G.L. Lander, J. Zarestky, C. Stassis, J. Metcalf, J.M. Honig, ICNS'91 (Oxford 27-30 august 1991) [Physica B (to be published)].

### Phase transformations and lattice instabilities in $\text{Pr}_2\text{NiO}_4$ .

M.T. Fernández-Díaz, J.L. Martínez and J. Rodríguez-Carvajal

The stoichiometric nickelates ( $\text{Ln}_2\text{NiO}_4$ , Ln = La, Pr and Nd) show two structural phase transformations in the temperature range from 1 to 2000 K [1-3]. At high temperatures the structure is tetragonal with space group  $I4/mmm$  (HTT). With decreasing temperature a continuous transformation into an orthorhombic structure (LTO) takes place. The space group of this new phase is  $Bmab$ . At lower temperatures a new tetragonal (LTT) phase is obtained showing a structure that can be described in the  $P4_2/nm$  space group. Such a sequence of transitions is quite peculiar because symmetry restoration is involved in the second transition to the low temperature phase LTT. This kind of transition has also been found in  $\text{La}_2\text{CoO}_4$  [4] and in the layered perovskites  $(\text{C}_n\text{H}_{2n+1}\text{NH}_3)_2\text{MX}_4$  with M = transition metal and X = halogen [5]. In  $\text{La}_2\text{CuO}_4$  only the first phase transformation is observed. However, a slight doping with Ba allows the presence of the second one in a limited range of Ba concentration [6]. Associated with the appearance of this new low temperature phase, the superconducting state is lost.

As shown in Fig. 1, the orientational relation between the HTT body centred unit cell, the B centred orthorhombic (LTO) unit cell and the primitive tetragonal (LTT) cell is given by the relations:

$$\begin{aligned} \mathbf{a}_{\text{LTO,LTT}} &= \mathbf{a}_{\text{HTT}} - \mathbf{b}_{\text{HTT}}; \\ \mathbf{b}_{\text{LTO,LTT}} &= \mathbf{a}_{\text{HTT}} + \mathbf{b}_{\text{HTT}}; \\ \mathbf{c}_{\text{LTO,LTT}} &= \mathbf{c}_{\text{HTT}}. \end{aligned} \quad (1)$$

The orthorhombic symmetry of the LTO phase appears as a consequence of the tilting of the  $\text{MO}_6$  (M = Cu, Ni or Co) octahedra around the  $[1\ 1\ 0]_{\text{HTT}}$  or  $[1\ -1\ 0]_{\text{HTT}}$  tetragonal axes, therefore giving rise to two types of domains. The critical temperature for this transition has been found to be 770 K for  $\text{La}_2\text{NiO}_4$ , while for  $\text{Pr}_2\text{NiO}_4$  the extrapolation of the temperature dependence of the orthorhombic strain indicates a value of  $T_{\text{C}2} = 1500$  K [3].

The second transition is related to a sudden change in direction of the tilt axis of the  $\text{MO}_6$  octahedra. In tetragonal  $P4_2/nm$ , the octahedra rotate around  $[1\ 1\ 0]_{\text{LTT}} = [1\ 0\ 0]_{\text{HTT}}$  in the  $z = 0$  plane and around  $[1\ -1\ 0]_{\text{LTT}}$  in the plane  $z = 1/2$ . For  $\text{Pr}_2\text{NiO}_4$  this transition has been observed for  $T_{\text{C}1} = 117$  K.

The atomic displacements involved in the  $\text{HTT} \rightarrow \text{LTO}$  transformation are characterized by the wave

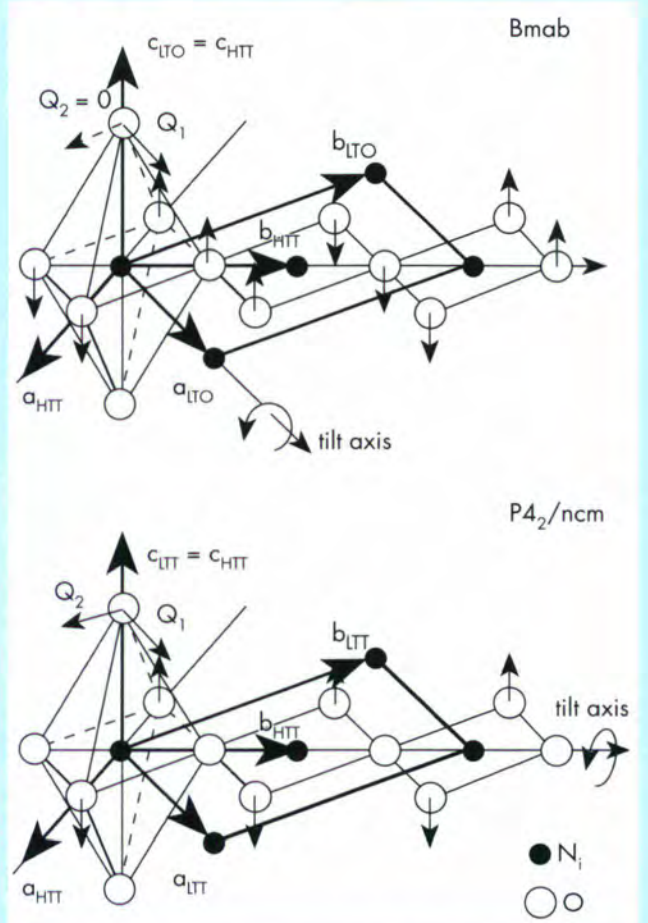

Fig. 1. Details of the oxygen atom displacements related to the HTT in the equatorial plane of  $\text{NiO}_6$  octahedra for a) orthorhombic  $Bmab$ , LTO and b)  $P4_2/nm$  phase, LTT. The  $Q_i$  indicate the order parameters which describe the different tilts.

vectors  $\mathbf{q}_1 = 1/2[1\ 1\ 0]$  and  $\mathbf{q}_2 = 1/2[1\ -1\ 0]$ , corresponding to a degenerated pair of soft mode phonons with amplitudes  $Q_1$  and  $Q_2$ .

This phase sequence can be interpreted phenomenologically by the sixth-order thermodynamic potential written in terms of  $Q_1$  and  $Q_2$  [7].

$$F = \frac{a}{2}(T - T_{\text{C}2})(Q_1^2 + Q_2^2) + u(Q_1^2 + Q_2^2)^2 + v(Q_1^4 + Q_2^4) + \frac{c}{2\eta^2} + \xi\eta(Q_1^2 - Q_2^2) \quad (2)$$

where  $\eta$  and  $\xi$  are related to the orthorhombic strain.

For HTT  $Q_1^2 = Q_2^2 = 0$  and both modes become unstable at  $T_{\text{C}2}$ . For the low temperature phases, the competition of the fourth order terms determines the appearance of one of the two low temperature phases (LTO or LTT).

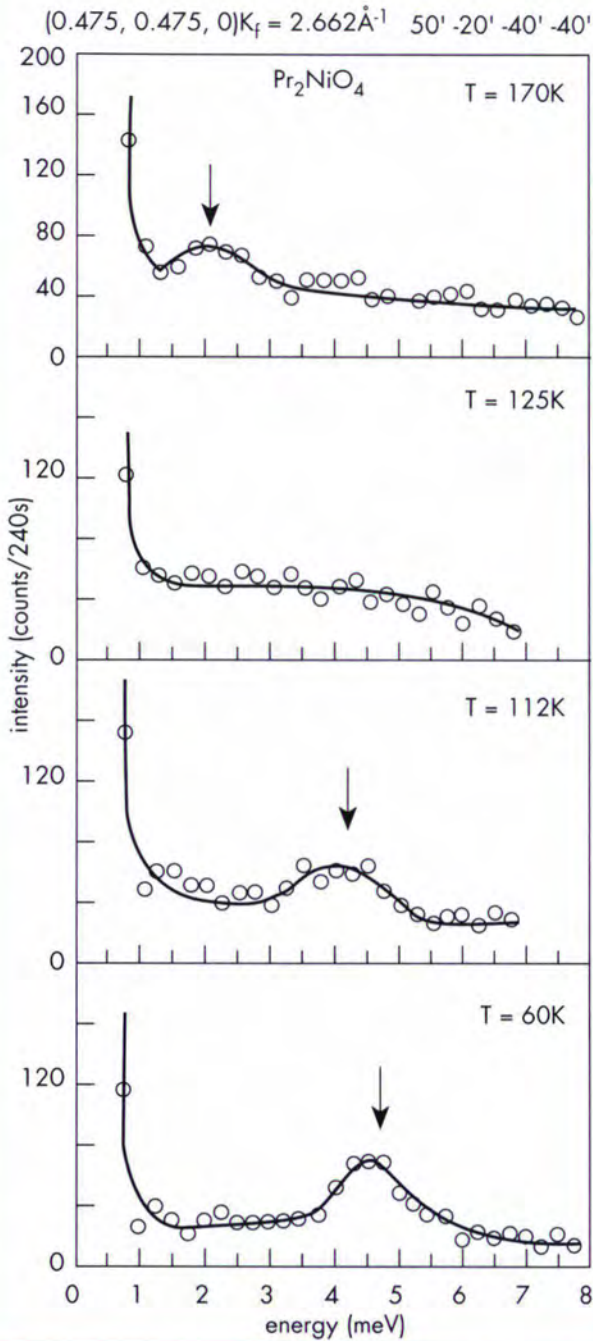

Fig. 2. Constant  $Q$ -scans at different temperatures around  $T_{C1} = 117$  K.

Minimization of the free-energy expansion yields two stable regions in the  $(u,v)$ -space.

1.  $v < 0$ ;  $(u+v) > 0$ , for which  $Q_1 \neq 0$  and  $Q_2 = 0$  (or  $Q_1 = 0$  and  $Q_2 \neq 0$ ), corresponds to the LTO structure.

2.  $v > 0$ ;  $(2u+v) > 0$ , for which  $Q_1 = Q_2 \neq 0$ , corresponding to the LTT structure.

In the LTO-phase the frequency  $\omega_1$  corresponding to the order parameter  $Q_1$  renormalizes rapidly with

decreasing temperature, while the frequency  $\omega_2$  corresponding to  $Q_2 (= 0)$  stays at lower frequencies.

To explain the LTO to LTT transformation one has to postulate the temperature dependence of the coefficient  $v$ , going from negative to positive values with decreasing temperature. This predicts that  $\omega_2$  behaves like a soft mode as a function of  $v$ :

$$\omega_2^2 = -4v Q_1^2 \quad (3)$$

By means of inelastic neutron scattering experiments performed on the triple-axis spectrometer IN8, we have observed the soft mode behaviour of  $\omega_2$  near  $T_{C1}$  for  $\text{Pr}_2\text{NiO}_4$ [7]. A region of reciprocal space suitable for the measurements of the soft TO phonon associated with the structural transition is along  $([0, 3-\zeta, 2]_{\text{LTO}})$  (near the  $(0\ 3\ 2)_{\text{LTO}}$  Bragg position). In spite of twinning, the reflection  $(0\ 3\ 2)$  cannot be mixed with its counterpart  $(3\ 0\ 2)$  as the latter reflection is forbidden in Bmab. The explored region in the reciprocal space referred to the HTT phase is therefore  $[1/2(3-\zeta), 1/2(3-\zeta), 2]_{\text{HTT}}$ ; i.e. along  $[\zeta\ \zeta\ 0]_{\text{HTT}}$ , near the zone boundary.

The inelastic spectra obtained at different temperatures around  $T_{C1}$ , near the  $(0\ 3\ 2)_{\text{LTO}}$  Bragg point, are presented in Fig. 2. The data show the  $\omega_2$  phonon at around 2 meV in the LTO phase. At low temperature (LTT) the phonon is clearly observed around 5 meV.

The temperature dependence of this phonon frequency near the zone boundary of the tetragonal setting (for three different values of  $\zeta$ ) is shown in Fig. 3. The low-lying optical mode of the LTO phase around 2 meV becomes slightly softer approaching  $T_{C1}$ , and suddenly becomes stiffer for  $T < T_{C1}$  with a discontinuous jump at the transition temperature.

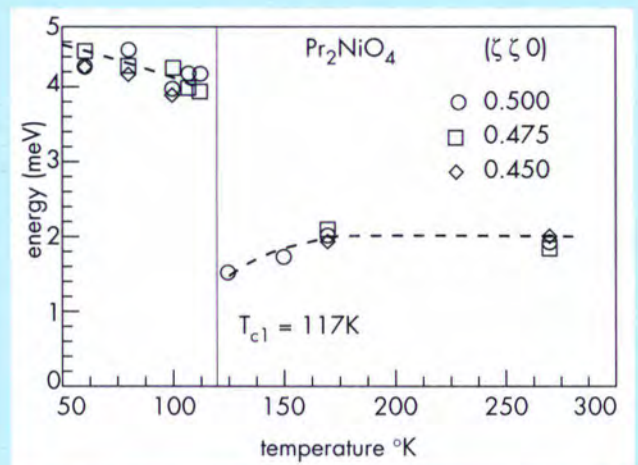

Fig. 3. Temperature dependence of the soft mode energy near the X-point.

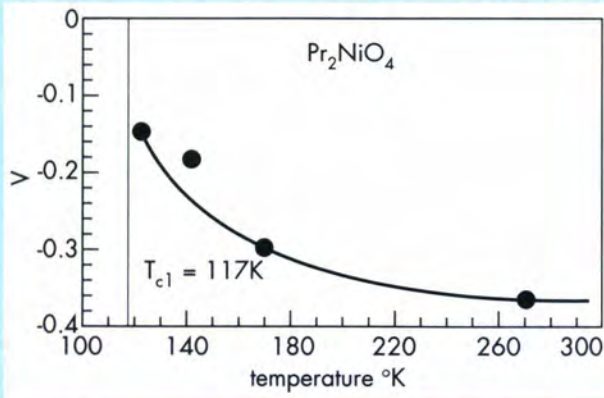

Fig. 4. Temperature dependence of the fourth order coefficient  $v$  in the Landau free energy expansion.

In LTO,  $v$  can be expressed by Eq. (3) in terms of the soft mode frequency  $\omega_2$  and the amplitude of the condensed order parameter  $Q_1$  as  $v = -\omega_2^2/4Q_1^2$ . The amplitude of the order parameter is related to the atomic displacements associated with the rotation of the octahedra. From our powder diffraction data we can calculate a quantity proportional to this amplitude. The temperature dependence of  $v$  is shown in Fig. 4, approaching  $T_{C1}$  the value of  $v$  gets closer to zero from the negative side, as expected from the Landau theory. Nevertheless a direct transformation from LTO to LTT can not be of second order, because the space groups are not related in such a way that one is a subgroup of the other. Both are different subgroups of the HTT space group.

It is worth comparing this oxide and isomorphous high  $T_C$  superconductor of  $\text{La}_2\text{CuO}_4$ -type. In general, magnetic and structural properties of layered nickelates differ little from those of copper oxides, except for the existence of the superconducting state. In particular the relation between this low temperature phase transformation (LTO  $\rightarrow$  LTT) and the suppression of superconductivity in  $\text{La}_{2-x}\text{Ba}_x\text{CuO}_4$  ( $x \approx 1/8$ ) have produced many theoretical models based on a collective electronic instability.

From the behaviour of the isomorphous insulator nickel oxides as well as the above mentioned layered perovskites [5], we can conclude that the transition must be mainly due to instabilities related to steric effects in this kind of structural type. Any effects on the electronic properties are therefore the consequence, and not the origin, of the structural instability.

### References

- [1] J. Rodríguez-Carvajal, M.T. Fernández-Díaz and J.L. Martínez, *J. Phys.: Condens. Matt.* **3**, 3215 (1991).
- [2] J. Rodríguez-Carvajal, M.T. Fernández-Díaz, J.L. Martínez, F. Fernández and R. Sáez-Puche, *Europhys. Lett.* **11**, 261 (1990).
- [3] M.T. Fernández-Díaz, J. Rodríguez-Carvajal, J.L. Martínez, G. Fillion, F. Fernández and R. Sáez-Puche, *Z. Phys. B* **82**, 275 (1991).
- [4] K. Yamada, M. Matsuda, Y. Endoh, B. Keimer, R.J. Birgeneau, S. Onodera, J. Mizusaki, T. Matsuura and G. Shirane, *Phys. Rev. B* **39**, 2336, (1989).
- [5] R. Geick and K. Strobel, *J. Phys. C* **10**, 4221 (1977).
- [6] J.D. Axe, A.H. Moudden, D. Hohlwein, D.E. Cox, K.E. Mohanty, A.R. Moodenbaugh and Youwen Xu, *Phys. Rev. Lett.* **62**, 2751 (1989).
- [7] J.L. Martínez, M.T. Fernández-Díaz, J. Rodríguez-Carvajal and P. Odier, *Phys. Rev. B* **43**, 13766 (1991).

## Crystal and Magnetic Structures

### Members of the College

M. Anne (CNRS)	S. Mason
J. Baruchel (ESRF)	G.J. McIntyre
R. Bateson	M.L. Medarde-Barragan
A. Boireau	H. Murphy
S. Bramwell	Z. Mursic
J. Brown	V. Nunez
T. Brückel	J. Pannetier
T. Chattopadhyay	A. Pearce
J.K. Cockcroft	H. Pillière
C. Cohen-Addad	M. Reehuis
P. Convert	C. Riekel (ESRF)
S. Dakin	C. Ritter
J.A. De Carvalho Paixao	V. Rodriguez
A. Filhol	J. Rodriguez-Carvajal
J.L. Garcia-Muñoz	J. Sandonis
A.W. Hewat	J. Schweizer (DRF CENG)
K. Hinrichs	J.L. Soubeyroux (CNRS)
R. Hock	F. Tasset
O. Isnard	P. Timmins
A. Kvik (ESRF)	C. Vettier (ESRF)
G. Lautenschläger	T. Vogt
M.S. Lehmann	M. Vrtis
M. Marezio (CNRS)	C. Wilkinson (EMBL)
J.C. Marmeggi (CNRS)	C. Zeyen

### Introduction

Even though the experimental activities of college 5 suffered from the reactor shutdown, 1991 has been a scientifically productive year. The over-demand on the instruments of the diffraction group showed the enormous interest and confidence of the user community in this particular scientific domain at the ILL. It is more than unfortunate that now as the work of the past was starting to pay off and new and interesting machines such as the quasi-Laue diffractometer (LADI) and D5B were about to take shape, a necessary repair of the reactor, with all its constraints and delays, brings the experimental activities to a sudden halt.

### Scientific Highlights in 1991

#### Crystallography

##### Anharmonicity and TDS in cobalt phthalocyanine

Cobalt phthalocyanine,  $\text{CoC}_{32}\text{N}_8\text{H}_{16}$  has interesting electronic properties with biological implications. It is a planar molecule of high symmetry (Fig. 1) for which charge and spin densities have been studied at high resolution by both polarized neutron and X-ray diffraction.

The 115 K charge-density X-ray study could not be interpreted in terms of a simple harmonic model for nuclear motion together with a valence electron density model. This raised the question of the extent of anharmonicity and the accuracy of the positional and thermal parameters derived from the X-ray data, considerations which are critical in any modelling of valence-electron density.

A neutron diffraction experiment at a wavelength of 0.75 Å was therefore carried out on the hot-source diffractometer D9, at the same temperature as the X-ray diffraction experiment, and extended further in reciprocal space than usual - up to the limit of the X-ray experiment. It allowed an examination of anharmonic effects and of the reliability of X-ray-defined thermal parameters.

After extensive least-squares refinement, the results were as follows: final  $R(F) = 0.018$ ,  $R(F^2) = 0.030$ ,  $S = 1.08$  for 2789 reflections, 1008 at  $\sin\theta/\lambda$  above  $7 \text{ nm}^{-1}$ , with anharmonic Gram-Charlier expansion refinement, and thermal diffuse-scattering (TDS) corrections derived from theoretical intermolecular potentials. The introduction of 715 cubic and quartic anharmonic parameters reduces  $R(F^2)$  by 0.011 and  $S$  by 0.11 from the values obtained in a harmonic refinement. Use of the local molecular approximate symmetry is not helpful in describing anharmonicity. Quartic parameters are more significant than cubic ones. Much of the anharmonic correction seems to result from intermolecular interaction affecting the relatively soft motion along  $b$ , resulting in one-particle potential wells with flat bottoms along  $b$ , but relatively harmonic potential in the  $ac$  plane. Agreement of positional parameters with the 115 K X-ray charge-density results is good, if similar

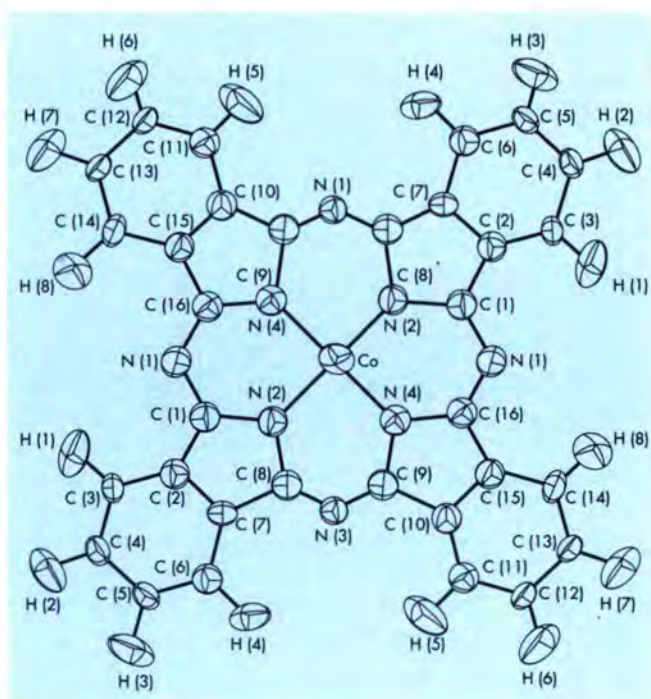

Figure 1: The harmonic thermal motion ellipsoids in cobalt phthalocyanine.

refinements are made. But the neutron thermal parameters are significantly lower than X-ray, 8% on average, probably reflecting a difference in the TDS correction in the two experiments.

The conclusion is that analysis of good quality X-ray and neutron data, even in quite harmonic crystals, even at low temperature, and only to  $10.8 \text{ nm}^{-1}$ , requires consideration of at least anisotropic TDS, anharmonicity, and valence deformation charge density. Up to  $7 \text{ nm}^{-1}$  anharmonicity and anisotropy (though not the isotropic component) in TDS may be neglected, without significantly affecting the deformation charge density or the positional parameters. (Collaboration with the University of Western Australia).

### Hydrogen Bonding and Disorder in Cyclodextrins

The torus-shaped cyclodextrins (CD's) are a family of cyclic oligosaccharides consisting of six ( $\alpha$ -CD), seven ( $\beta$ -CD), eight ( $\gamma$ -CD), or nine ( $\delta$ -CD) D-glucoses connected by  $\alpha(1-4)$  interglucose bonds. They readily form inclusion complexes with guest molecules of suitable size, which are of interest in the study of noncovalent interactions, and have many industrial applications. Many of the complexes crystallize so well that they can be studied by X-ray and neutron diffraction techniques. As each of the glucoses has three free hydroxyl groups and the crystal structures always contain several hydration solvent molecules, a large number of O-H...O hydrogen bonds are formed, which are interconnected into complicated three-dimensional networks. The guest molecules enclosed in the cyclodextrin cavities tend to be more or less disordered. Crystalline cyclodextrin complexes are excellent model systems to study ordered and disordered hydrogen-bonding networks which are of considerable biological interest.

Comparisons have now been published of well-refined neutron diffraction determinations of structures of  $\beta$ -CD.11D<sub>2</sub>O and  $\beta$ -CD.EtOD.8D<sub>2</sub>O at low temperature, and of  $\beta$ -CD.EtOD.8D<sub>2</sub>O at 295K and 15K. The structures of a 1:1 cyclopentanone:  $\alpha$ -CD inclusion complex at 20K (see 1987 Annual Report) of  $\alpha$ -CD.6H<sub>2</sub>O and of  $\beta$ -CD.11 D<sub>2</sub>O at room temperature, and of partially-deuterated  $\gamma$ -CD.15.7 D<sub>2</sub>O at 110K are available as well.

In the room-temperature crystal structure of  $\alpha$ -CD.6H<sub>2</sub>O, a well-ordered system of rings and chains of hydrogen bonds was observed. In  $\beta$ -CD.11H<sub>2</sub>O the situation is more complex. Neutron diffraction revealed that at room temperature the 11 water molecules per asymmetric unit are disordered over 16 positions, of which only three are fully occupied. Five water molecules and 15 (out of 21) hydroxyl groups of the  $\beta$ -CD molecule display orientational disorder, where the hydrogen (deuterium) atoms are found in partially occupied discrete sites.

Many of these disordered groups are interconnected to form structures of the type

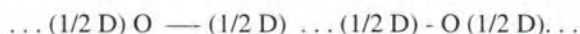

They were called "flip-flop" hydrogen bonds and interpreted as a dynamical equilibrium.

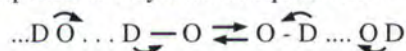

The dynamic nature of the disorder was confirmed by a neutron diffraction study at  $T = 120 \text{ K}$ , well below a phase transition observed at  $T = 227 \text{ K}$ . It showed that the water molecules and hydroxyl groups order upon cooling, which is unlikely for static disorder. Molecular dynamics computer simulations predicted water mobility in the  $\beta$ -CD cavity and changes in hydrogen bond orientation on a time scale of  $10^{-11} \text{ s}$ . This was experimentally supported by quasielastic neutron scattering experiments, which showed strong local diffusive motions of hydrogen atoms in a powder sample.

To check whether these properties are specific to  $\beta$ -CD.11H<sub>2</sub>O or are characteristic of other cyclodextrin complexes as well, neutron diffraction analyses were carried out for the related complex  $\beta$ -CD ethanol octahydrate ( $\text{C}_6\text{H}_7\text{D}_3\text{O}_5$ )<sub>7</sub>.C<sub>2</sub>D<sub>5</sub>OD.8D<sub>2</sub>O, at  $T = 295 \text{ K}$  and  $T = 15 \text{ K}$ , and an X-ray structure analysis of the same compound at room temperature. A calorimetric study (DTA and DSC) has shown an exothermic phase transition at  $T = 236 \text{ K}$  (in the

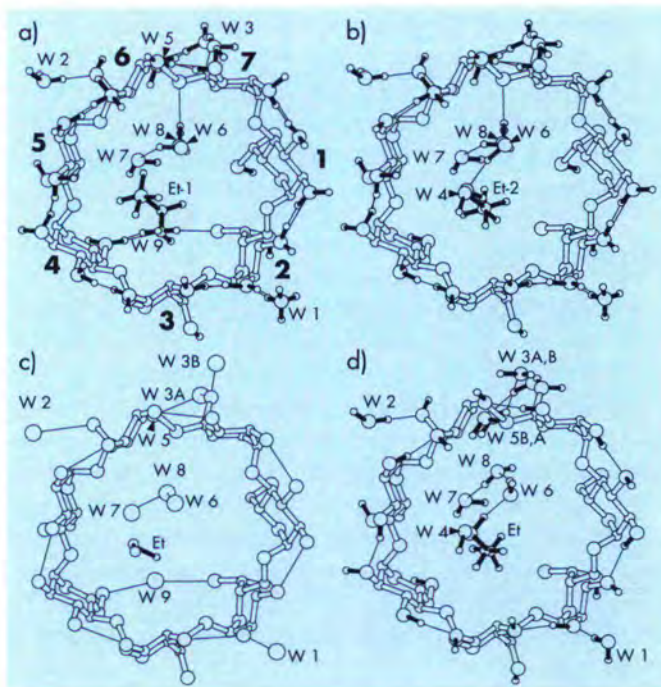

Figure 2: One asymmetric crystal unit of the inclusion complex  $\beta$ -CD-EtOD-8D<sub>2</sub>O, with projection along the  $\beta$ -CD molecular axis. C-H hydrogen atoms in the  $\beta$ -CD molecule are omitted for clarity, O-D and C-D bonds are drawn solid, and hydrogen bonds are shown as thin lines: (a) neutron structure,  $T = 295 \text{ K}$ , major site of the ethanol molecule ( $\text{occ} = 0.612$ ), all alternative sites are drawn for disordered groups outside the  $\beta$ -CD cavity; (b) as in (a), but minor site of the ethanol molecule ( $\text{occ} = 0.32$ ); (c) X-ray structure,  $T = 295 \text{ K}$ , the site of the ethanol molecule is fully occupied; and (d) neutron structure,  $T = 15 \text{ K}$ , the site of the ethanol molecule is fully occupied.

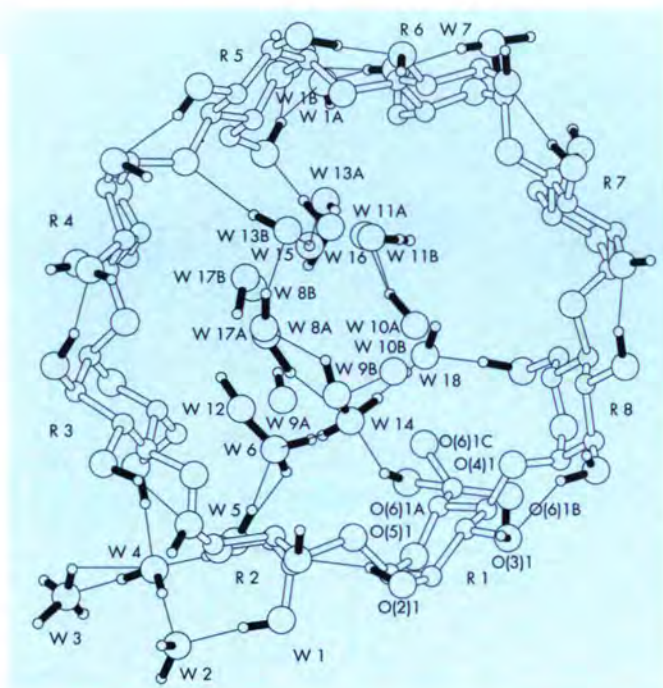

Figure 3: View of one asymmetric unit in the crystal structure of  $\gamma$ -CD.15.7D<sub>2</sub>O. Projection is along the  $\gamma$ -CD molecular axis; C-H hydrogen atoms of the  $\gamma$ -CD molecules are omitted for clarity; O-D bonds are drawn solid, and hydrogen bonds are indicated by thin lines.

nondeuterated compound). The neutron structure of  $\beta$ -CD.EtOD.8D<sub>2</sub>O at  $T = 15$  K, shows almost perfectly ordered solvent molecules and hydroxyl groups.

Fig. 2 summarizes some of results for the solvent molecules included in the  $\beta$ -CD moiety of the ethanol complex, and Fig. 3 shows an analogous view of the somewhat more complex situation in  $\gamma$ -CD.15.7 D<sub>2</sub>O at 110 K.

As well as providing a wealth of reasonably accurate geometrical data on CD's these studies have allowed some more general conclusions to be drawn e.g.:

(1) In  $\beta$ -CD . EtOD.8D<sub>2</sub>O, orientational disorder of the *flip-flop* type is observed for 16 of the 21  $\beta$ -CD hydroxyl groups and for seven of the nine water sites. Furthermore, two CH<sub>2</sub>(6)-O(6) groups are orientationally disordered. These different types of disorder parallel those found in  $\beta$ -CD undecahydrate. In both crystal structures, they almost completely disappear upon cooling.

(2) The analysis of six cyclodextrin neutron structures showed that simultaneous contacts  $<3.5$  Å of a hydroxyl or water oxygen atom to O(5) and O(6) of the same glucose are indicative of three-centre hydrogen bonding with  $\sim 90\%$  reliability. If in such a three-centre bond O(6) is the donor, O(5) accepts the minor component; if the contacting oxygen is the donor, O(5) can accept a major component as well as O(6). A substantial fraction of all the hydrogen bonds in the CD's are of the three-centre or even the four-centre type,

in which a donor forms hydrogen bonds to two or three acceptor atoms. If the van der Waals cutoff criterion  $d_{H...O} < 2.6$  Å is used,  $\sim 29\%$  of the hydrogen bonds are of the three-centre type, if the more permissive criterion  $d_{H...O} < 3.0$  Å and  $\alpha O-H...O > 90^\circ$  is applied,  $\sim 47\%$  are of the three-centre and  $\sim 7\%$  are of the four-centre type.

(3) Perhaps more surprisingly, significant differences were found between the neutron and the X-ray structures for  $\beta$ -CD . EtOD.8D<sub>2</sub>O, most likely because of differences between the crystals used in the two analyses. Similar observations were made for  $\beta$ -CD hydrate; and for Vitamin B<sub>12</sub> hydrate by other workers. (Collaboration with Free University of Berlin and Oak Ridge).

### High Temperature Structural Studies

In the past one and a half years we have become involved in the development of mirror furnaces for single crystal and powder diffraction. At the moment we are working with two types of furnaces :

1) a "classical" mirror furnace where the heating is provided by two 1000 W halogen lamps. Temperatures up to 2000 K can be reached in air, vacuum or a variety of other gases. The temperature measurements are carried out with Pt/Pt(Rh10%) thermocouples.

2) a mirror furnace based on an arc-lamp with which we hope to achieve 3000 K in air. Here the temperature measurements are carried out with a two-colour pyrometer. Both furnaces are controlled by a Eurotherm controller adapted to both types of temperature measurements .

The "classical" mirror furnace was tested on various occasions in both single crystal and powder experiments. The photograph (see page 88) shows the mirror furnace set up in the Eulerian cradle of D19. With this setup single crystal diffraction in air up to 2000 K was performed.

The mineral zircon (ZrSiO<sub>4</sub>) can substitute U and/or Th on the Zr positions in the lattice. The  $\alpha$ -particles emitted by these elements destroy the crystal lattice. This process is called metamictization. Single crystal and powder diffraction experiments at high temperature have been carried out on this compound. The results were briefly described in the Annual Report 1990.

In another powder diffraction experiment, the high-temperature phase of perovskite (CaTiO<sub>3</sub>) was studied. This material is an important model compound for the earth's most abundant mineral (Mg,Fe)SiO<sub>3</sub>. There have been indications that (Mg,Fe)SiO<sub>3</sub> undergoes a temperature-induced phase transition to a cubic phase before melting and that this phase is a solid electrolyte. This would be of major importance for all geophysical models since the thermodynamic, elastic and rheological properties of solid electrolytes differ considerably from normal salts. The isostructural CaTiO<sub>3</sub> has a smaller orthorhombic distortion from the cubic 'aristotype' than (Mg,Fe)SiO<sub>3</sub>. Experimental evidence suggests that the distortion increases with pressure

and decreases with temperature. Both compounds should undergo similar phase transitions on heating. Fig. 5 shows that there is a first order phase transition to a cubic perovskite between 1550 and 1600 K. The figure also demonstrates the good relative reproducibility with which the temperature of the furnace can be controlled. The sample was first heated up (full circles: 300 K, 675 K, 1050 K, 1250 K, 1550 K, 1650 K, 1875 K) afterwards cooled down (triangles: 1600 K, 1000 K, 750 K, 500 K) and then heated again to 875 K and 1400 K. If one examines the evolution of the equivalent atomic displacement parameters (a.d.p.'s) it seems as if the phase transition is due to the onset of ionic mobility in the oxygen sublattice. In the orthorhombic perovskite phase up to 1400 K the a.d.p.'s. of the two different oxygens are very similar as can be seen in Fig. 5. At 1550 K the oxygen in the *ab*-plane ( $\Delta$ ) indicates a very strong disorder whereas the one located along the *c*-axis ( $\blacksquare$ ) does not deviate noticeably from the expected linear temperature dependency. The diagrams also show strong diffuse scattering supporting the existence of a disordered liquid-like oxygen sublattice. The large a.d.p.'s. of the oxygens in the *ab*-plane at 1550 K can be understood by the tilts the  $\text{TiO}_6$  octahedra have to perform to transform into the cubic structure. The fact that they are of the same magnitude as those in the cubic phase suggests that the transformation into the high temperature phase is triggered by the sudden mobility increase of the oxygen. This also explains the fact that no tetragonal phase is observed since it is known that under normal circumstances there is no possibility of reaching a  $\text{Pbnm}$  orthorhombic structure from a  $\text{Pm}\bar{3}\text{m}$  cubic structure by a single symmetry reduction process.

### Dimorphism in $\text{Tm}_2\text{BaNiO}_5$

The new family of  $\text{R}_2\text{BaNiO}_5$  oxides (hereafter called R-BNO, R: rare earth) was first described by Schiffler and Müller-Buschbaum when they synthesized Nd-BNO as a single crystal and established that it crystallizes with an orthorhombic symmetry ( $\text{Immm}$ ). Subsequent studies reported the same structural type for the oxides with  $\text{R} = \text{Nd} \rightarrow \text{Tm}$ . The main structural feature of this new type of structure is the existence of one-dimensional chains of vertex-sharing ( $\text{NiO}_6$ ) flattened octahedra along the *a*-axis (see Fig. 6). As a result of this unusual distortion, the Ni-O(axial) distance is very short, 1.87 Å in the case of Y-BNO, suggesting very interesting physical properties due to an expected enhancement of the superexchange interaction Ni-O(axial)-Ni. In this sense, evidence for strong 1-D antiferromagnetic correlations from magnetic susceptibility data has been recently reported for Y-BNO. On the other hand, the oxides Yb-BNO and Lu-BNO are isostructural and crystallize in the well-known "green phase" structural type, with space group  $\text{Pnma}$ . This structure (Fig. 6) can be described as forming a framework built up from monocapped  $\text{RO}_7$  prisms while the nickel atoms show five-fold coordination giving rise to isolated and distorted  $\text{NiO}_5$  pyramids. Although  $\text{Tm}^{3+}$  and  $\text{Yb}^{3+}$  have a similar

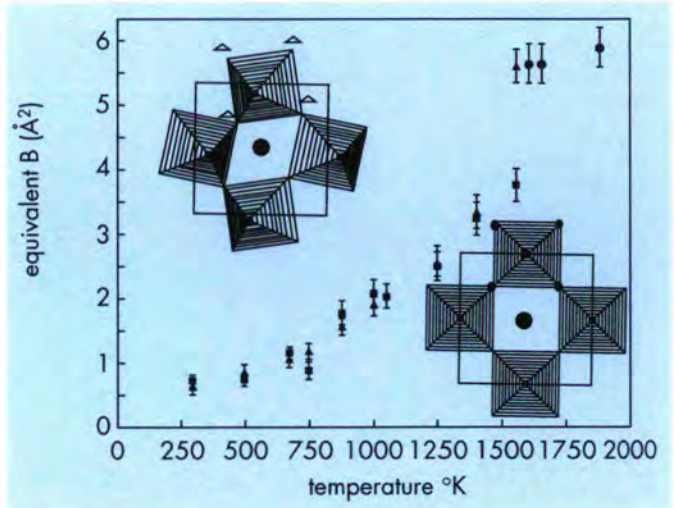

Figure 5: Thermal evolution of a.d.p.'s. and schema of the perovskite structure (see text).

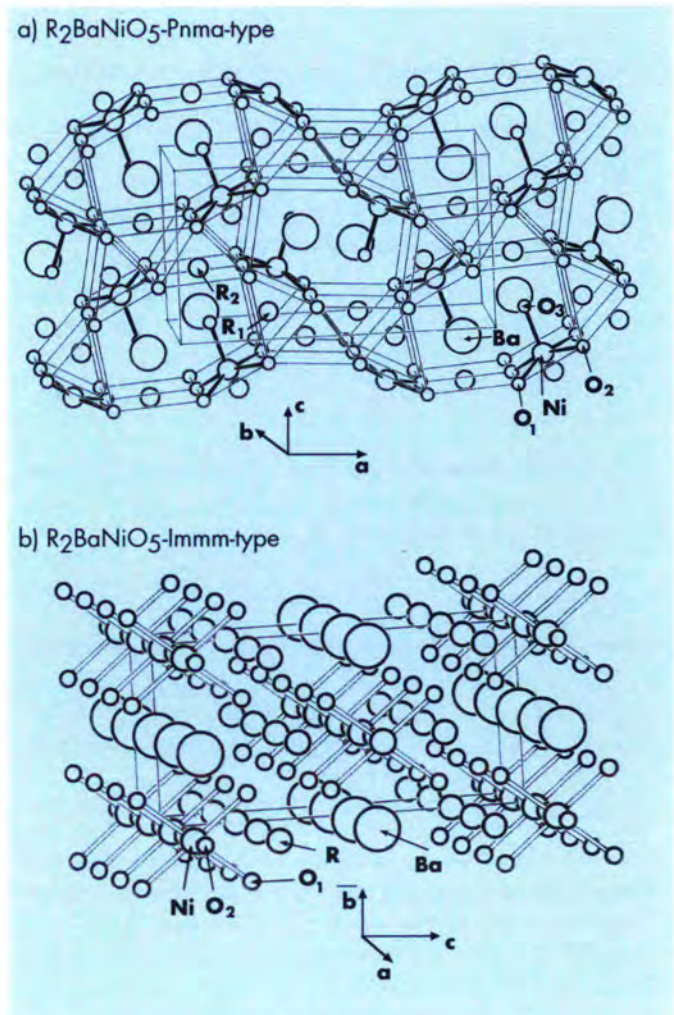
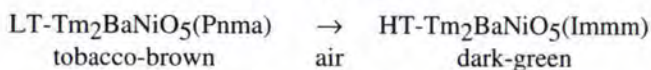

Figure 6: Structure of  $\text{Tm}_2\text{BaNiO}_5$ . a) Low temperature phase. b) High temperature phase.

size, the reported structures are very different. In fact Tm-BNO is a dimorphic compound. The new coloured low-temperature (LT) phase is isomorphous to Yb-BNO, space group Pnma (Z=4) with lattice parameters  $a \approx 12.20 \text{ \AA}$ ,  $b \approx 5.66 \text{ \AA}$ ,  $c \approx 6.97 \text{ \AA}$ . After heating this phase in air at 1600K for 24 hours the green coloured Tm-BNO described earlier is obtained. The space group is Immm with lattice parameters  $a \approx 3.75 \text{ \AA}$ ,  $b \approx 5.72 \text{ \AA}$ ,  $c \approx 11.25 \text{ \AA}$ . This implies the existence of a phase transition according to:

$$1500 < T_c < 1600 \text{ K}$$



No structural relation exists between the LT and HT forms of Tm-BNO. It can be observed that only the 7-coordination for thulium remains, the average Tm-O distance is 2.31 Å for the LT-form, while in the case of the HT-form it is slightly higher (2.33 Å). For barium and nickel different environments are observed for both phases. Moreover there is a very different three-dimensional packing arrangement of these polyhedra. This transition appears to involve strong displacements of the heavy atoms as can be observed by comparing the very different distances obtained for the Tm-Tm and Ni-Ni in both phases. It is worth noting that the shortest Ni-Ni distance  $\approx 3.75 \text{ \AA}$  obtained in the HT-form increases drastically for the LT-form to a value of  $\approx 5.04 \text{ \AA}$ .

### Intercalation of Li in Molybdenum Sulphide Chevrel Phases

Binary and ternary Chevrel phases with the composition Mo<sub>6</sub>X<sub>8</sub> and A<sub>x</sub>Mo<sub>6</sub>X<sub>8</sub> (X = S, Se, Te; A = main group or transition metal) are of great interest due to their superconducting properties and their large variety of chemical and physical properties depending on the guest cation. They are known to undergo reversible topotactic redox reactions at ambient temperature via electron/ion transfer according to :

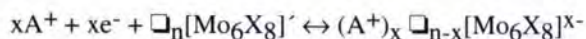

The electrons are accepted by appropriate levels of the host band and the resulting excess negative charge is compensated by the simultaneous uptake of mobile cations A<sup>+</sup> in empty lattice sites □. The binary phase has a rhombohedral structure (space group R $\bar{3}$ ) and can be described by a three dimensional arrangement of Mo<sub>6</sub>X<sub>8</sub> units, which themselves consist of X<sub>8</sub> cubes surrounding the distorted Mo<sub>6</sub> octahedra. Smaller cations such as Li<sup>+</sup>, Cu<sup>+</sup> or Ni<sup>2+</sup> form the so-called Chevrel phases of type II where the rhombohedral unit cell gets compressed in direction of the 3 fold symmetry axis. The squeezing of the X<sub>8</sub> cube leads to the formation of two groups of 6 potential lattice sites with distorted tetrahedral symmetry arranged on two concentric rings around the unit cell origin (inner and outer sites).

Four distinct rhombohedral Li<sub>x</sub>Mo<sub>6</sub>S<sub>8</sub> phases with x = 1, 3, 3.8 and 4 have been identified by electrochemical intercalation. <sup>7</sup>Li-NMR data determined line shifts of -15 ppm for x = 1 and  $\approx 5$  ppm for x = 4, while the presence of an extremely low Li NMR line shift in Li<sub>3</sub>Mo<sub>6</sub>S<sub>8</sub> ( $\approx 80$  ppm) was interpreted as the result of the formation of (Li<sub>3</sub>)<sup>2+</sup> clusters with electron deficient multicentre metal bonding. From the analysis of the second moment a Li-Li distance of about 2.7 Å within this hypothetical cluster was determined. High resolution neutron powder diffraction patterns were collected on D2B for the phases with x=1, 3 and 4. Rietveld refinement showed that in Li<sub>1</sub>Mo<sub>6</sub>S<sub>8</sub> the intercalated cations occupy exclusively sites on the inner concentric ring (Fig. 7a). The small diameter of this ring precludes the simultaneous occupation by 2 cations; a small Li-S distance ( $\approx 2 \text{ \AA}$ ) confirms here the ionic bonding as indicated by the NMR line shift. In the phase Li<sub>3</sub>Mo<sub>6</sub>S<sub>8</sub> the geometrical situation has completely changed. Inner and outer sites become occupied in a ratio 1 to 2 with the inner ring being strongly enlarged (Fig. 7b). The formation of (Li<sub>3</sub>)<sup>2+</sup> clusters on the inner ring is now possible and leads to a Li-Li separation of about 2.3 Å. An arrangement of the outer sites leads to an intracuster distance of 4 Å. The intracuster diffusion between outer and inner sites is made possible by short site separations ranging between 1.36 Å and 1.62 Å. Interpreting the relative occupancies of inner and outer sites as a static picture whose positions vary with time of symmetric (Li<sub>3</sub>)<sup>2+</sup> clusters the value of the NMR second moment and the extreme NMR Knightshift was well reproduced and explained. The intercalation of the fourth Li to form Li<sub>4</sub>Mo<sub>6</sub>S<sub>8</sub> results in the contraction of the inner ring and the expansion of the outer one (Fig. 7c). The relative occupation is now 1 to 3, the intracuster diffusion between inner and outer sites is strongly hindered by the enlarged separation.

### Desorption of Deuterium in Nd<sub>2</sub>Fe<sub>17</sub>D<sub>5</sub>.

The high value of magnetization reached in the rare earth compounds of formula R<sub>2</sub>Fe<sub>17</sub> compounds is due to the iron content, but the Curie temperature remains low. However, interstitial compounds having the formula R<sub>2</sub>Fe<sub>17</sub>X<sub>x</sub> (X=C, N) are among the most promising hard magnet materials. Hydrogen insertion yields spectacular changes in the magnetic properties: a rise of 60% in the Curie temperature and an increase of about 40% in the room temperature magnetization for Nd<sub>2</sub>Fe<sub>17</sub>H<sub>4.9</sub>.

The technological application of hydrogenation for making micro-magnetic particles (the so called "powder decrepitation method"), raised the interest in correlating the fundamental magnetic properties and hydrogen absorption.

Real time neutron diffraction using the diffractometer D1B, enabled the deuterium desorption process in Nd<sub>2</sub>Fe<sub>17</sub>D<sub>4.9</sub> to be investigated. This corresponds to the occupation of two different interstitial sites: D(1) (almost octahedral) takes up 3D/f.u., D(2) (tetrahedral) remains unsaturated at 1.9 D/f.u..

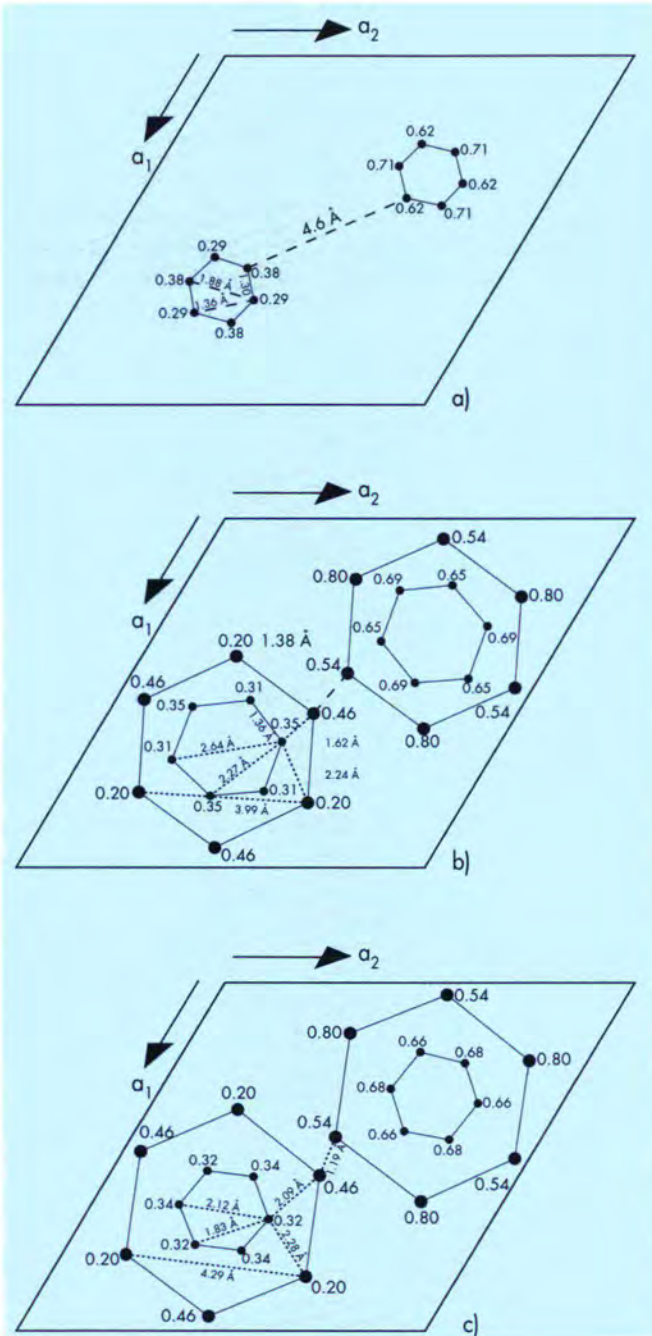

Figure 7: Geometrical arrangement of inner (•) and outer (•) sites in a)  $\text{Li}_1\text{Mo}_6\text{S}_8$ , b)  $\text{Li}_3\text{Mo}_6\text{S}_8$ , c)  $\text{Li}_4\text{Mo}_6\text{S}_8$ . The z-coordinates as well as selected intra and intercluster Li-Li distances are indicated.

The experiment was performed in vacuum. No effect is observed up to 400K. The D-site occupancies versus temperature are shown in Fig. 8. Both sites exhibit different behaviour : D(2) loses deuterium at a lower temperature than D(1), which seems thermally more stable.

At about  $T_1=400\text{K}$  the occupancy of the D(2) site decreases upon heating and at  $T_3=500\text{K}$ , this site becomes empty. The curve describing this desorption resembles a thermally activated process. The linear shape, between  $T_1$  and  $T_3$ , indicates a regular loss of hydrogen.

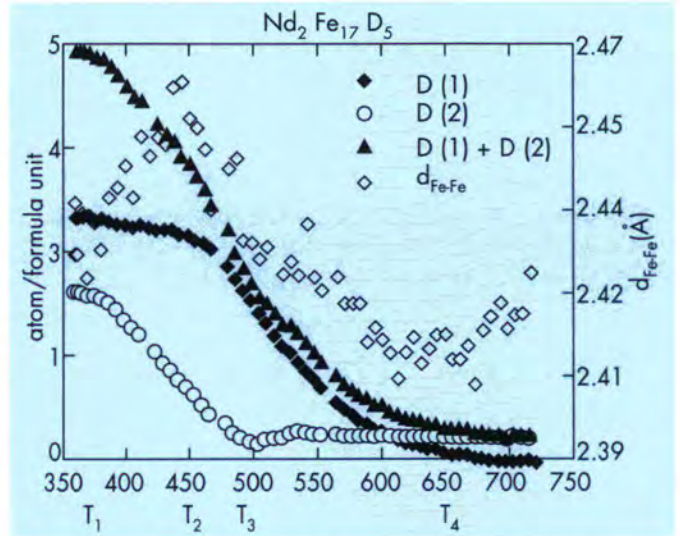

Figure 8: Deuterium content per interstitial site as a function of the temperature in  $\text{Nd}_2\text{Fe}_{17}\text{D}_5$  (in atoms per formula unit). The variation of the shortest Fe-Fe distance is shown.

On the D(1) site, the deuterium begins to escape at higher temperature  $T_2=470\text{K}$ . The desorption from D(1) ends at about  $T_4=670\text{K}$ . The slope of D(1) site is larger than that of D(2) site. This means the removal of deuterium from D(1) is faster.

It has been observed that hydrogen insertion in  $\text{Nd}_2\text{Fe}_{17}$  is fully reversible and desorption leads to the original  $\text{Nd}_2\text{Fe}_{17}$  alloy, at temperatures higher than  $T_4$ .

The lattice parameters plotted in Fig. 9 reveal that both  $a$  and  $c$  are affected by desorption. The change in  $c$  seems to be closely related to the occupancy of the D(2) site, and can be described in the same three stages:

- from RT to  $T_1$  there are no significant changes in  $c$  other than the normal thermal expansion.
- between  $T_1$  and  $T_3$ ,  $c$  decreases regularly as D(2) loses its charge. Between  $T_3$  and  $T_4$  only a small decrease of  $c$  is observed during the D(1) desorption, indicating that  $c$  is mainly affected by the filling of the D(2) site.
- for  $T > T_4$ , the  $c$  parameter of  $\text{Nd}_2\text{Fe}_{17}$  increases due to the thermal expansion of the lattice.

The behaviour of the  $a$  parameter is more complex and exhibits two different stages. A first decrease occurs during D(2) desorption; a change of slope is observed after  $T_2$  and then the decrease ends when D(1) is definitively empty.

The shortest interatomic distances between iron atoms are plotted also in Fig 8. This distance is well known to play a major role in the magnetic interactions: in  $\text{Nd}_2\text{Fe}_{17}$ , Fe-Fe very short distances lead to negative exchange interactions according to the Néel-Slater curves. The low Curie temperature of these alloys is attributed to the anomalously short Fe-Fe distances.

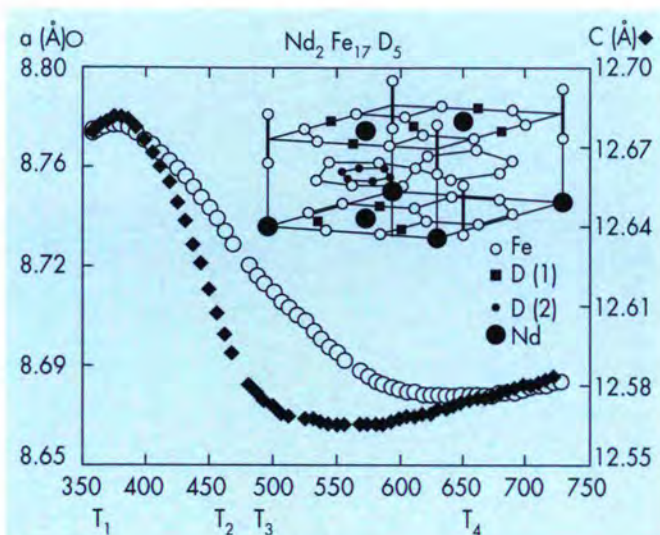

Figure 9: Variation of the lattice parameters as a function of the temperature during the desorption process of  $Nd_2Fe_{17}D_5$ . The two deuterium sites are shown in the structure.

The inset in Fig.9 reveals how the insertion of the D into the D(1) site relaxes the iron pairs and favours a positive exchange interaction between two Fe atoms, leading to a higher Curie temperature and magnetization.

This work has shown that the two interstitial sites have different affinity towards hydrogen. D(1) is more stable than D(2). The anisotropic cell expansion observed upon deuterium insertion and the behaviour of the shortest Fe-Fe distances are both influenced by the insertion-desorption process. Thus, the results of this experiment have allowed a better understanding of the magnetic properties of these interesting materials.

## Crystallography and Magnetism

### 3D Magnetic Behaviour of $RMn_2$ compounds.

Rare earth (R) - transition metal (M) intermetallics based on the formula  $RM_2$  and collectively known as Laves phase compounds are ideal model systems for studying the interplay between structural, electronic and magnetic properties. The class of  $RMn_2$  compounds shows exceptional properties, since depending on the rare earth, different magnetic structures can be found.  $RMn_2$  compounds crystallize either in the cubic C15 or the hexagonal C14 structure with the Mn atoms lying at the vertices of regular tetrahedra. It was pointed out that antiferromagnetic ordering of Mn must always be highly frustrated. Unusual magnetic structures due to topological frustration were found for  $PrMn_2$  and  $NdMn_2$ .  $YMn_2$  is a further example in this series; here the onset of the Mn moment ( $\mu_{Mn}=2.8\mu_B$ ) is accompanied by a huge magnetovolume anomaly ( $\Delta V/V=5\%$ ). Until now it seemed that the Mn-Mn interatomic distance played a crucial role in allowing the formation of an inherent Mn moment: below a

critical distance of about  $d_c=2.67\text{\AA}$  no volume anomaly was observed and the Mn site was thought nonmagnetic. Powder diffraction on D1B showed, however, that in  $DyMn_2$  ( $d_{Mn-Mn}=2.66\text{\AA}$ ) a spin canted ferromagnetic arrangement of the rare earth sublattices ( $k=[1/2, 1/2, 1/2]$ ) leads to an induced moment on one of the four chemically equivalent sites ( $\mu_{Mn}=1.4\mu_B$ ). These magnetic Mn atoms are located on sites with a strongly polarizing magnetic environment resulting from a near-neighbour configuration of ferromagnetically coupled Dy spins. The cancellation of a moment on the other Mn sites can be interpreted as a signature of the instability of Mn moments in a very highly frustrated lattice. A similar study on  $HoMn_2$  (here  $d_{Mn-Mn}=2.63\text{\AA}$ ) revealed a magnetic structure identical to that of  $DyMn_2$ ;  $\mu_{Mn}=0.6\mu_B$ .

$TbMn_2$  ( $d_{Mn-Mn}=2.73\text{\AA}$ ) is an ideal candidate to test the response of the 3d-magnetism to external parameters such as applied field, pressure or alloying. Neutron diffraction experiments on a single crystal have been performed on D15 using a cryomagnet giving a vertical field up to 6.5T [6]. On cooling in zero field  $TbMn_2$  undergoes a transition to an antiferromagnetic phase which is accompanied by a magnetovolume anomaly of  $\Delta V/V=1.5\%$ . Ignoring smaller magnetic satellites (a second incommensurate propagation vector not yet determined) the magnetic structure (S1) is generated by a propagation vector  $k_1=[2/3, 2/3, 0]$ . Applying the field a second set of lines (S2) corresponding to  $k_2=[1/2, 1/2, 1/2]$  appears. Fig.10 shows the intensity variation of the antiferromagnetic peaks characteristic of  $k_1$  and  $k_2$  as a function of applied field at 25K. The intensity of a line indicating a ferromagnetic component on the Mn lattice is

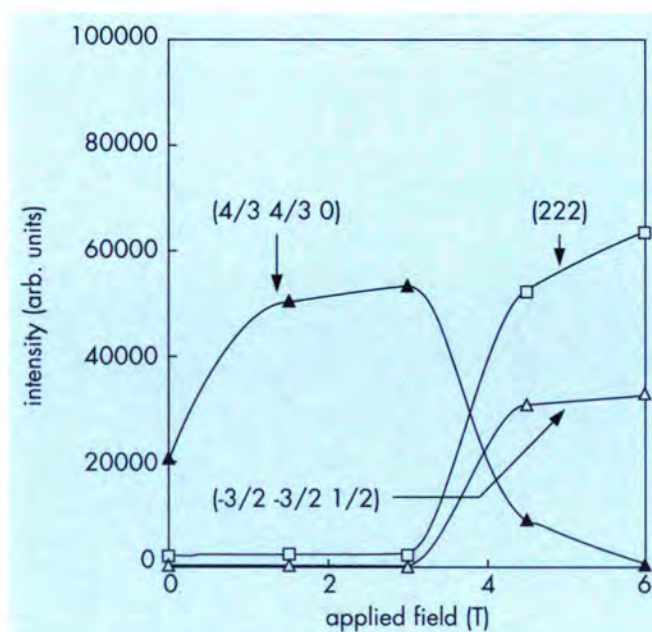

Figure 10: Field dependence of the  $(4/3\ 4/3\ 0)$  and  $(-3/2\ -3/2\ 1/2)$  peaks of  $TbMn_2$  characteristic of the S1 and S2 structure respectively. The  $(2\ 2\ 2)$  peak is characteristic of the ferromagnetic component of the Mn sublattice.

also shown. The relative stability of the two magnetic structures is seen to depend strongly on H, at a critical field of 4.5T a transition from S1 to S2 is observed. This critical field increases with decreasing temperature. Apart from the additional ferromagnetic component on the Mn sublattice the S2 and the DyMn<sub>2</sub> structure are identical.

A transition from S1 to S2 was observed as well when applying external pressure: reducing the lattice parameter of TbMn<sub>2</sub> at a rate of 0.009Å/kbar the localised moment at the Mn site becomes unstable and at P=2kbar only the DyMn<sub>2</sub> type structure persists at low temperature.

Alloying - that means exerting an internal or chemical pressure - has been used to study more closely the S2 structure in Tb(Mn<sub>0.96</sub>Fe<sub>0.04</sub>)<sub>2</sub>. High resolution data on D2B permitted the detection of a rhombohedral distortion at the onset of magnetic order. The 16d Mn site of the cubic structure (Fd3m) splits into two non-equivalent sites 1b and 3d in the rhombohedral structure (R3). One finds that the 1b site is magnetic (1.4μ<sub>B</sub>) while the 3d site remains non-magnetic.

A very sensitive test to determine the crossover between inherent Mn moment (PrMn<sub>2</sub>,NdMn<sub>2</sub>,TbMn<sub>2</sub>,YMn<sub>2</sub>) and induced Mn moment (DyMn<sub>2</sub>,HoMn<sub>2</sub>,TbMn<sub>2</sub> under applied field or pressure, Tb(Mn<sub>0.96</sub>Fe<sub>0.04</sub>)<sub>2</sub>) is the study of the pseudobinary system Dy<sub>x</sub>Y<sub>1-x</sub>Mn<sub>2</sub>. The phase diagram can be seen in Fig. 11. For x<0.2 the magnetic behaviour is similar to that of YMn<sub>2</sub> with an antiferromagnetic ordering of the first kind (AF1) for the FCC lattice of Mn tetrahedra. Dy<sub>0.2</sub>Y<sub>0.8</sub>Mn<sub>2</sub> undergoes a first phase transition into the AF1 structure at 70K which is accompanied by a volume anomaly of ΔV/V=5.4%. The inherent moment amounts to 2.7μ<sub>B</sub>. At lower temperatures, however, the system undergoes a second reentrant type phase transition where the

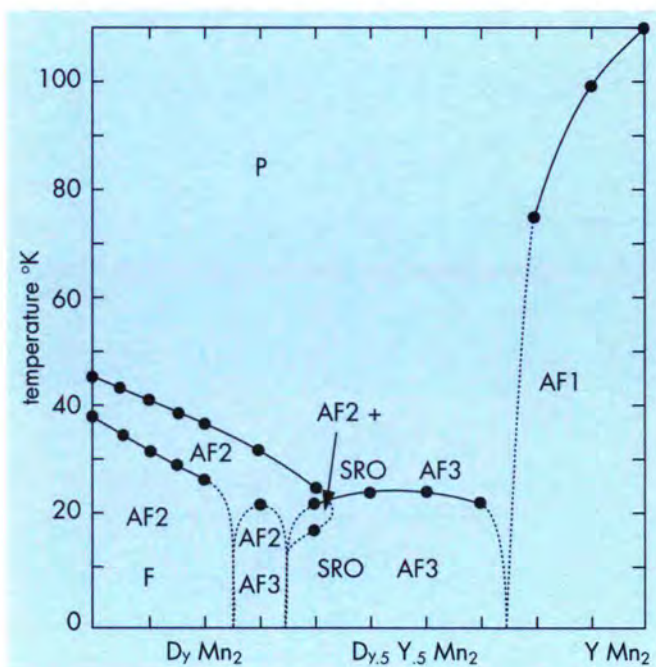

Figure 11: Magnetic phase diagram of Dy<sub>x</sub>Y<sub>1-x</sub>Mn<sub>2</sub>.

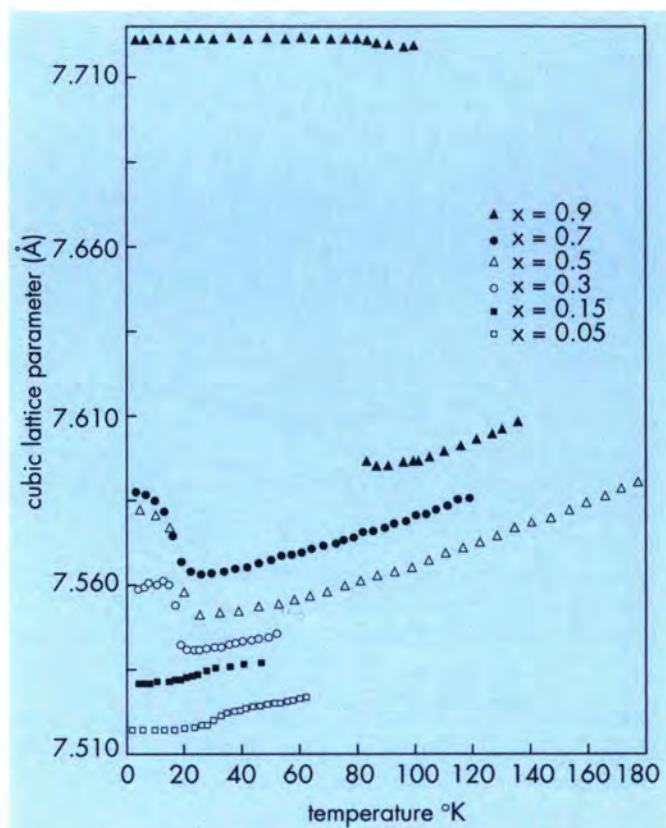

Figure 12 : Thermal expansion behaviour of the pseudobinary system Dy<sub>x</sub>Y<sub>1-x</sub>Mn<sub>2</sub>. A volume anomaly exists down to x=0.3

decrease of the Mn moment to now 2.0μ<sub>B</sub> is accompanied by a volume contraction of ΔV/V=-1%. For x>0.8 the DyMn<sub>2</sub> structure is found, Dy<sub>0.7</sub>Y<sub>0.3</sub>Mn<sub>2</sub> sees the ferromagnetic coupling (F) replaced by a second antiferromagnetic one (AF3). This coupling persists as short range correlations (SRO-AF3) into a wide range of intermediate concentrations. Despite the absence of any long range order the presence of a residual inherent Mn moment could be inferred from the thermal expansion behaviour of the system: Fig.12 shows clearly how the volume anomalies accompanying the onset of local moment formation persist in a reduced form down to x=0.3.

Doping YMn<sub>2</sub> with a small amount of Ce results in a decrease of the cubic lattice parameter and therefore of d<sub>Mn-Mn</sub>. This is surprising as Ce<sup>3+</sup> has a larger ionic radius than Y<sup>3+</sup>; we attribute this to the existence of a strong hybridisation of the Ce 4f and Mn 3d bands. The volume fraction of material which undergoes the transition to the antiferromagnetic state diminishes rapidly from 70% for Ce<sub>0.01</sub>Y<sub>0.99</sub>Mn<sub>2</sub> to 13% in Ce<sub>0.03</sub>Y<sub>0.97</sub>Mn<sub>2</sub>. The volume expansion decreases at the same time from 4.7% to 4.2% with the ordered moment decreasing from 2.7μ<sub>B</sub> to about 1.5μ<sub>B</sub>. Contrary to Tb(Mn<sub>0.96</sub>Fe<sub>0.04</sub>)<sub>2</sub> and Dy<sub>x</sub>Y<sub>1-x</sub>Mn<sub>2</sub> there is no crossover to the S2 or the DyMn<sub>2</sub> type magnetic structure: in Ce<sub>x</sub>Y<sub>1-x</sub>Mn<sub>2</sub> the rare earth sublattice is nonmagnetic and cannot induce any magnetic moment on the Mn sites.

### Temperature-induced movement of chirality-domain walls in helimagnets.

When working with ferromagnetic materials it is possible to modify the domain distribution just by applying a magnetic field. That is not the case with chirality domains where only the use of special properties of the crystals allows a modification of the domain structure. It had been observed by polarized neutron topography on S20 that the Average Chirality-Domain Size, ACDS, increases in Tb when the helimagnetic phase is reached from a ferromagnetic one, and when the temperature is modified within the helimagnetic phase.

An investigation performed on a high quality MnP crystal shows similar results from magnetic diffracted intensity measurements in the helimagnetic phase ( $T < 47\text{K}$ ). Its crystalline perfection was used to infer, through extinction effects, the evolution of the ACDS when cycling in temperature within the helimagnetic phase. A given type of chirality domains only diffracts at a given neutron polarization. Consequently, neighbouring chirality domains are optically incoherent, and the magnetic perfection of the crystal is thus related with the ACDS. The smaller the ACDS the stronger the magnetic diffracted intensity due to a reduction of extinction. Fig. 13 shows a decreasing magnetic intensity when cycling the sample inside the helimagnetic phase, the nuclear intensity remaining constant. This means that the magnetic perfection of our sample is increasing thus also the ACDS. All these experimental results imply a movement of the chirality domain walls.

The model proposed to explain this movement is based on the temperature variation of the pitch of the helix. A simple geometrical argument shows that this requires domain walls to move in order to preserve the helimagnetic structure if the wall position, or the orientation of moments inside the walls, are not completely free but constrained by energy terms. Fig. 14 shows the evolution of the domain pattern predicted for the model in the simple case.

Equations governing the evolution of the system are reversible, thus cycling in temperature one expects a reversible shift of domain walls, provided the irreversible process of annihilation of domain walls does not take place. If, in the course of displacement, two neighbouring walls meet they vanish. The reverse process of creating new domain walls is not possible. Hence the ACDS can increase but never decrease. Further cycling can lead to the possibility of losing more domains.

### Antiferromagnetic ordering in $\text{Gd}_2\text{CuO}_4$

The recent discovery of a family of superconductors  $\text{R}_{2-x}\text{A}_x\text{CuO}_4$  ( $\text{R} = \text{Pr, Nd, Sm, Eu}$ ;  $\text{A} = \text{Ce, Th}$ ) has stimulated numerous investigations on these compounds. In contrast to other high-temperature superconductors the charge carriers involved in the superconductivity of this series are electrons, rather than holes. These compounds

have interesting magnetic properties including the coexistence of antiferromagnetism and superconductivity. The copper sublattice orders antiferromagnetically in the temperature range 250 - 275 K, whereas the rare earth sublattice orders only at very low temperatures. Amongst the  $\text{CuO}_4$  family  $\text{Gd}_2\text{CuO}_4$  seems to be especially interesting for several reasons. Although  $\text{Gd}_2\text{CuO}_4$  is as easily doped with Ce or Th as the other members of the family, it does

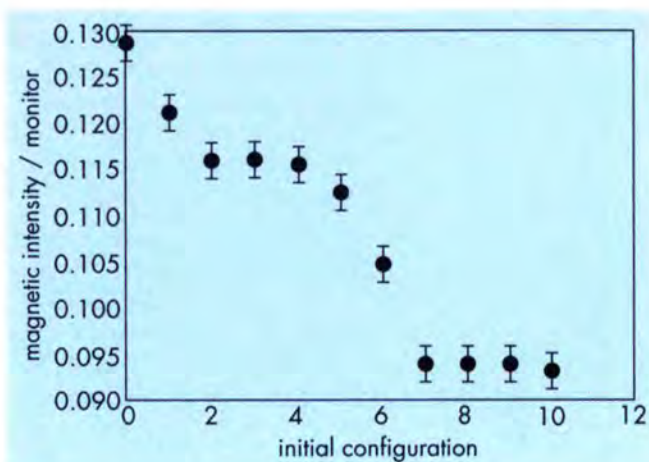

Figure 13: Dependence of the magnetic diffracted intensity on the number of thermal cycles for one satellite of the (200) Bragg reflection of MnP. The sample was cooled from an initial temperature of 250K to 15K and then it was cycled inside the helimagnetic phase between  $T=45\text{K}$  and  $T=15\text{K}$ . Intensity measurements were always taken at  $T=15\text{K}$ .

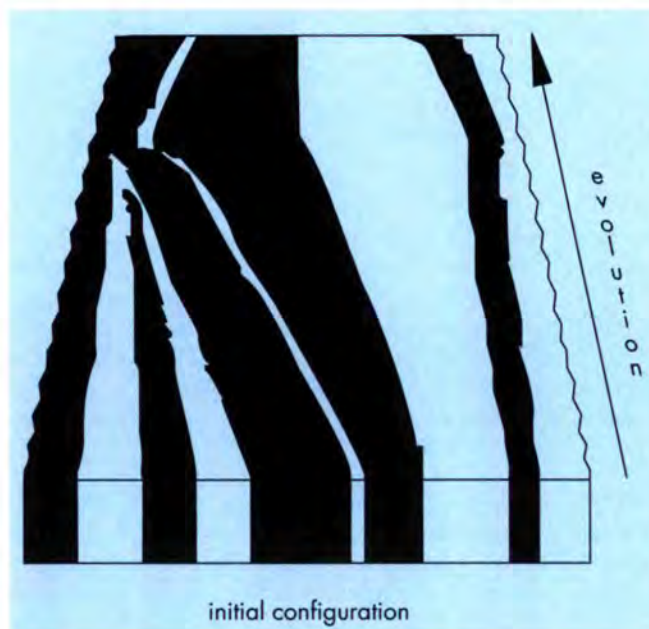

Figure 14: Evolution of a chirality-domain structure for a simple case: the propagation vector of the helix was just varied from 0.1 to  $0.06 \text{ \AA}^{-1}$ , (half a thermal cycle), with just an anisotropic energy term for the moments inside the domain walls, in a sample of 1mm size.

not, as they do, become superconducting. There have been several suggestions to explain the absence of superconductivity in this compound, but no clear explanation has yet been given. The antiferromagnetic ordering of the  $\text{CuO}_2$  layers is reported to be accompanied by the appearance of a weak ferromagnetic moment, the magnitude of which is inversely proportional to the temperature, although an intrinsic weak ferromagnetism moment is forbidden by the crystal symmetry  $I4/mmm$  of  $\text{Gd}_2\text{CuO}_4$ . The weak ferromagnetism may be due to the presence of impurities, but this needs to be proved by experiment. In contrast to  $\text{La}_2\text{CuO}_4$  and  $\text{YBa}_2\text{Cu}_3\text{O}_{6+x}$ , the doped as well as the undoped  $\text{R}_2\text{CuO}_4$  compounds preserve their tetragonal symmetry down to the lowest temperatures investigated. Because of the tetragonal symmetry a non-collinear double-k magnetic structure may exist in this system and this possibility has been investigated by neutron diffraction.

Neutron diffraction investigations were made on a crystal ( $4.0 \times 4.0 \times 0.4 \text{ mm}^3$ ) using the diffractometer D15 with wavelength  $1.176 \text{ \AA}$ . Between  $6.4$  and  $2.5 \text{ K}$  the intensity of the fundamental reflections increased markedly but no extra reflections of magnetic origin could be found. This indicates that the Gd sublattice orders with a propagation vector  $\mathbf{k} = (0,0,0)$ . Since magnetization measurements on our samples show no ferromagnetic moment, the two Gd atoms related by the centre of symmetry must have oppositely directed moments. The observation of magnetic intensity in the  $004$  and  $006$  reflections excludes the possibility that the magnetic moments are parallel to  $[001]$  but because of strong absorption in the plate-like crystal the quality of the intensity measurements was not sufficient to show whether or not the moments are confined to the  $a$ - $b$  plane. The magnetic structure consists of ferromagnetic  $(001)$  planes antiferromagnetically stacked along  $[001]$ .

Fig. 15 shows the field dependence of the antiferromagnetic resonance frequency for magnetic fields parallel to  $[100]$  and  $[110]$ . The behaviour for the two field directions is very different and can be well understood if the antiferromagnetic moment direction is  $\langle 110 \rangle$ . When a magnetic field is applied parallel to  $[100]$  or  $[010]$ , the magnetic moments in the ferromagnetic layers start to rotate from the  $\langle 110 \rangle$  directions to the direction perpendicular to the magnetic field leading to a spin-reorientation transition at the critical field  $H_c = 0.88 \text{ T}$ . For  $H // [110]$  the field dependence of the resonance frequency is typical of a spin system without degeneracy and with no ferromagnetic moment.

Fig. 16 shows the variation of the sublattice magnetization derived from the intensity of the  $(112)$  reflection as a function of  $T/T_N$ , where  $T_N$  is the temperature at which the Gd sublattice orders. The continuous curve is the least squares fit of the expression  $F = F_0(1-T/T_N)^\beta$  to the data. The fit gives  $F_0 = 134(2)$ ,  $T_N = 6.370(5) \text{ K}$  and  $\beta = 0.234(9)$ . The critical exponent  $\beta$  obtained is much less than the three-dimensional Heisenberg or Ising value, but greater than the two-dimensional Ising value  $0.125$ . The quasi-two-dimensional behaviour is not unexpected because of the layer structure of  $\text{Gd}_2\text{CuO}_4$ .

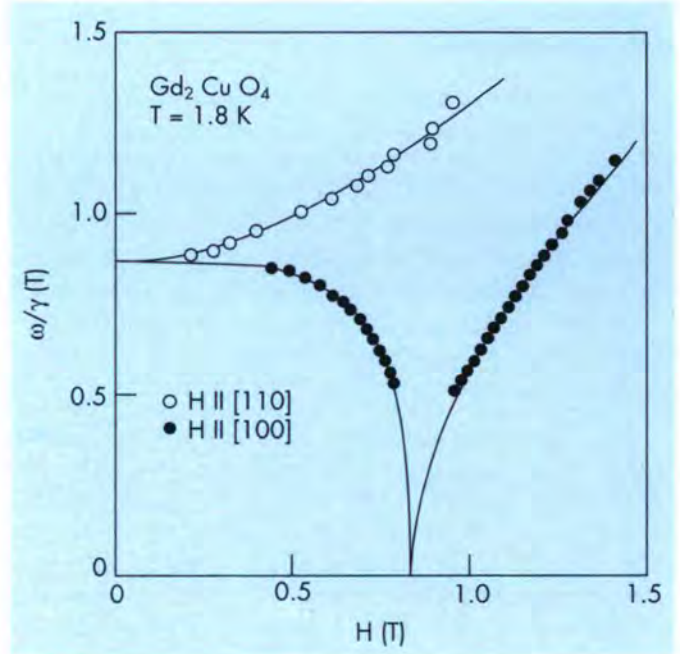

Figure 15: Magnetic field dependence of the antiferromagnetic resonance frequency of  $\text{Gd}_2\text{CuO}_4$  with magnetic fields applied parallel to  $[100]$  and  $[110]$ .

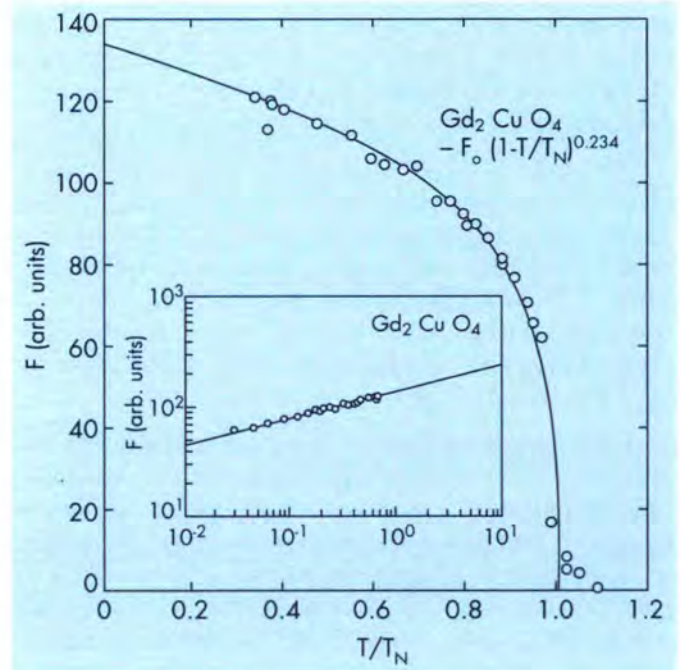

Figure 16: Temperature variation of the square root of the magnetic intensity of the  $(112)$  reflection as a function of the reduced temperature  $T/T_N$ . The continuous curve is the least squares fit of the data to the expression  $F = F_0(1-T/T_N)^\beta$  ( $\beta = 0.234$ ). The inset shows the corresponding log-log plot.

In conclusion neutron diffraction measurements have established the three dimensional magnetic ordering of Gd in  $\text{Gd}_2\text{CuO}_4$  below  $T_N = 6.4$  K and show unambiguously that the structure consists of ferromagnetic (001) planes stacked antiferromagnetically along [001]. Antiferromagnetic resonance measurements supplement these conclusions by showing that the magnetic moments of Gd ions are parallel to  $\langle 110 \rangle$ .

### Magnetic Phase Transitions in $\text{MnWO}_4$

Neutron powder diffraction data, collected on D1B and single crystal data collected on D10, show that  $\text{MnWO}_4$  (space group  $P2_1/c$ ) undergoes three magnetic phase transitions below 14K. The transition temperatures are 13.7K, 12.5 K and 6.8 K respectively.

The periodicity of the spin configurations is found to be identical for the two upper phases. These phases are incommensurate and can be described by a propagation vector  $\mathbf{k} = (-0.214, 1/2, 0.457)$ . The corresponding magnetic structures can be both described by a sinusoidal variation of the magnetic moments of the  $\text{Mn}^{2+}$  ions differing in their direction. Between 13.7 and 12.5 K the magnetic moments are in the a-c plane; below 12.5 K a component along [010] develops.

The third magnetic phase exists below 6.8 K. The structure is commensurate with a propagation vector  $\mathbf{k} = (1/4, 1/2, 1/2)$ . The magnetic moments are again collinear in the a-c plane. Fig. 17 shows the observed and calculated patterns of the three magnetic phases and a scheme of the commensurate spin configuration.

Though the complex magnetic behaviour of  $\text{MnWO}_4$  is not yet fully understood, it is probably due to the delicate balance between the super-exchange interactions along the edge-sharing octahedra chains and the super super-exchange interactions between chains.

### Unusual Magnetic Structure in the Insulator Regime of $\text{RNiO}_3$ (R=Pr,Nd) Perovskites.

The discovery of a Metal-Insulator (M-I) transition in perovskites  $\text{RNiO}_3$  (R=Pr,Nd) has triggered off much research activity on these compounds. Whereas rhombohedral  $\text{LaNiO}_3$  remains a metallic Pauli paramagnet at low temperature, orthorhombic  $\text{PrNiO}_3$  and  $\text{NdNiO}_3$  become insulators below 135K and 200K respectively. High resolution powder diffraction has been used to determine the possible structural changes accompanying the M-I transition. The results indicate that no further distortion with respect to the metallic phase exists in the insulating phase. Both phases have the same space group  $Pbnm$ . The only structural change, on going from the metallic ( $T > T_c$ ) to the insulator ( $T < T_c$ ) regime, is a sudden lattice expansion related to an increase of the Ni-O distances, and concomitant tilt of  $\text{NiO}$  octahedra, which enhances slightly the orthorhombic distortion.

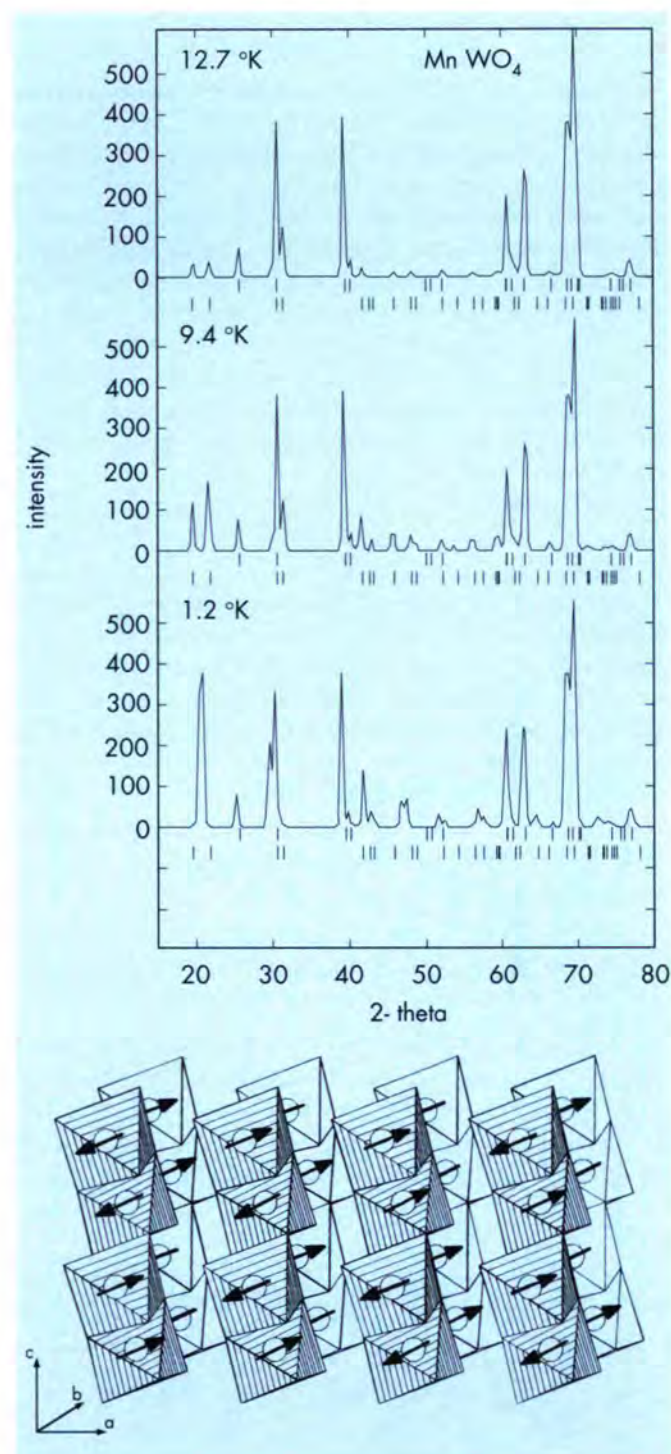

Figure 17: Observed and calculated patterns of the three magnetic phases of  $\text{MnWO}_4$ . The magnetic structure of the commensurate phase is also depicted.

In addition, small reflections appeared below  $T_c$  which can be indexed with a propagation vector  $\mathbf{k} = (1/2, 0, 1/2)$  with respect to the orthorhombic  $Pbnm$  cell ( $a \approx b = a_c \sqrt{2} < c \approx 2a_c$ ,  $a_c$  being the pseudo-cubic cell parameter). Polarization analysis performed on IN20 demonstrated the pure magnetic origin of these reflections. The observed propagation vector

is unprecedented in a perovskite oxide. The magnetic periodicity involves four Ni-Ni distances ( $\approx a_c$ ) along the three spatial directions: the propagation vector with respect to the pseudo-cubic cell is  $(1/4, 1/4, 1/4)$ . The magnetic structure corresponds to a ferromagnetic alignment of the four equivalent Ni along  $[100]$  in the  $Pbnm$  cell, which propagates according to  $\mathbf{k}$ . The refined magnetic moment of Ni, using the spherical form factor of  $Ni^{3+}$ , is  $0.90(3)\mu_B$ . The overall antiferromagnetic structure implies the existence of an equal number of ferromagnetic (F) and antiferromagnetic (AF) interactions between crystallographically equivalent Ni ions. The explanation of this peculiar spin arrangement was found in the breakdown of the nearly degenerate  $Ni(III)-t_{2g}^6 e_g^1$  electronic configuration and the setting up of an orbital superlattice. In Fig. 18 a scheme of the magnetic structure and the orbital superlattice is shown: different shaded squares represent the different occupied orbitals ( $d_{z^2}$  or  $d_{x^2-y^2}$ ). If two adjacent squares are of the same (different) type, the same (different) orbital is occupied, the interaction is AF (F). As no additional distortion appears, this could be the first experimental evidence of an orbital superlattice whose origin is not the Jahn-Teller effect. A theoretical model for the orbital superlattice was developed some years ago by Cyrot and Lyon-Caen in the framework of the Hubbard model with a degenerated upper  $E_g$ -band. The breakdown of the degeneracy, and the subsequent orbital superlattice, is due to pure correlation-exchange effects.

#### Extinction in mixed magnetic and nuclear reflections : a study of the magnetic structure of $TbAlO_3$ .

As part of a programme to determine the absolute magnetic configurations in magneto-electric crystals single crystals of  $TbAlO_3$  have been studied with zero field neutron polarimetry using CRYOPAD installed on IN20 and neutron integrated intensity measurements carried out on

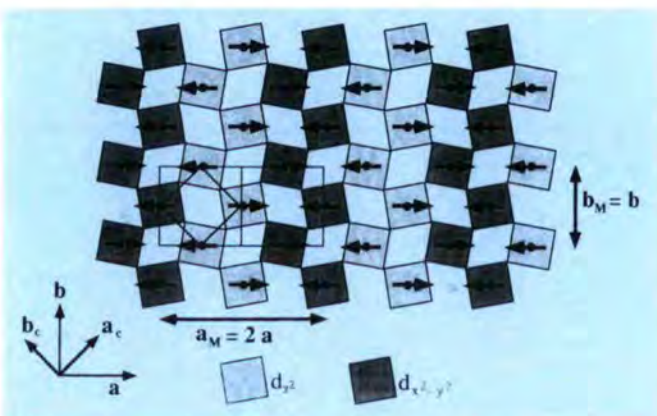

Figure 18: Scheme of the basal layer (001), representing the magnetic ordering of the Ni ions in the structure of  $RNiO_3$  ( $R=Pr, Nd$ ). The magnetic structure is obtained by stacking the layers in the sequence  $AA(AA)AA(AA)\dots$  where  $(AA)$  represent a bilayer with spins opposite to  $AA$ .

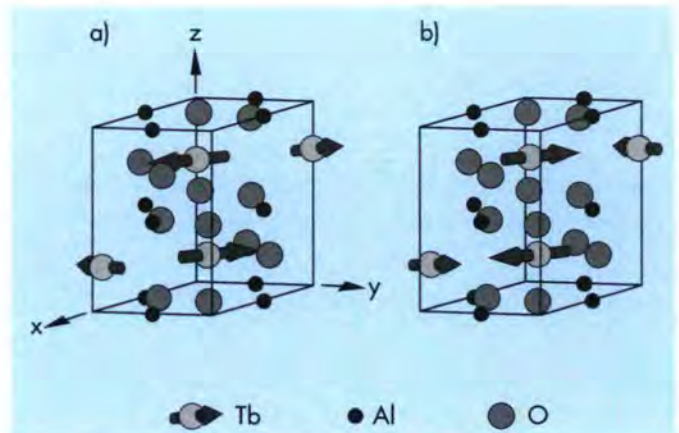

Figure 19: The magnetic structure of  $TbAlO_3$ . (a) and (b) represent the two different  $180^\circ$  domains.

D15. In magneto-electric crystals the two  $180^\circ$  domains are distinguishable by the directions of the magnetic moments with respect to the centres of symmetry and for  $TbAlO_3$  the two configurations are shown in Fig. 19. It was found that the results of neither the integrated intensity nor the polarimetry measurements could be understood using a simple model for extinction in the rather good untwinned crystals that were used. To explain the results the Becker-Coppens extinction model has been extended to the case where several magnetic domains occur within one block of the nuclear structure. In this case different mosaic block sizes determine the extinction for nuclear and magnetic scattering and hence different extinction parameters must be used to describe the nuclear, the magnetic, and the interference scattering. Using a rather simplified model the expressions giving both the integrated intensities and the scattered polarizations have been calculated and introduced into least squares refinement procedures. It has been shown that the model can provide a consistent interpretation of both sets of measurements. The results for the magnetic structure are in good agreement with a previous powder diffraction study. The polarization analysis results indicate an essentially equal population of  $180^\circ$  domains showing that any difference in energy between the two structures illustrated in Fig. 19 must be less than about  $2 \times 10^{-5}$  eV. The relative magnitudes found for the domain radii for nuclear and magnetic scattering ( $r_N/r_M \sim 16$ ) suggest that there are about 4000 magnetic domains within each relatively perfect "mosaic block". Given equal energies for the  $180^\circ$  domains this large number accounts for the equality of the domain populations, since the statistical fluctuations with such large numbers will be small. The large number also shows that the energy of the magnetic defects associated with the  $180^\circ$  domain wall must also be small, since many such domain walls must be present.

This extinction model could apply to any magnetic structure in which magnetic domains can be formed at a magnetic phase transition when such formation is not accompanied by a significant lattice distortion. It is particularly applicable to magnetic structures with zero propagation vector, since it allows the extinction in the nuclear-magnetic interference term to be calculated, which cruder models, with separate nuclear and magnetic extinction, do not. It could be applicable to unmagnetized ferromagnets; but unfortunately ferromagnetic domain walls cause neutron depolarization, so only integrated intensity measurements could be used to obtain the parameters in this case. The present measurements have shown that integrated intensity measurements at a single wavelength were not able to determine all the parameters of the extinction model independently. The results of the polarization analysis, on the other hand, did enable all the parameters to be determined, which illustrates once again the power of neutron polarimetry.

### Magnetic excitations and spin correlations in CuO

The magnetic properties of CuO resemble to a large extent those of undoped  $\text{La}_2\text{CuO}_4$  and  $\text{YBa}_2\text{Cu}_3\text{O}_6$ . Unlike the latter compounds, CuO does not have two-dimensional  $\text{CuO}_2$  layers but has approximate square planar coordination with four oxygen atoms. Zigzag O-Cu-O chains exist which are parallel to  $[1,0,-1]$ . The magnetic susceptibility shows only minute anomalies at the Néel temperature and continues to increase above  $T_N$  showing a broad maximum at about 600 K and finally decreases at higher temperatures. The 1990 ILL report described quasielastic neutron scattering investigations on CuO which showed the existence of anisotropic spin correlations above  $T_N$ . The correlation length along  $(1,0,-1)$  was observed to be resolution limited but is certainly larger than that along the approximately perpendicular direction, parallel to  $(1,0,1)$ . These measurements have been repeated with much improved resolution, and the magnetic excitations of the low temperature antiferromagnetic phase investigated. The new measurements show that at 230 K the correlation length parallel to  $(1,0,-1)$  is about 700 Å, which is much larger than the correlation length of 200 Å parallel to  $(1,0,1)$ . The correlation lengths along both these directions decrease continuously with increasing temperature, being reduced by a factor of three at 235 K. Least squares fits of the observed inverse correlation lengths  $\kappa$  to the expression:  $\kappa = \kappa_0 (T/T_N - 1)^\nu$ , gave  $T_N = 229.0(1)$  K and  $\nu = 0.62(3)$  for  $\kappa_{//}$  which is parallel to  $(1,0,-1)$  and  $T_N = 229.3(2)$  K and  $\nu = 0.45(3)$  for  $\kappa_{\perp}$ . Fig. 20 shows the corresponding log-log plots. The critical exponents for  $\kappa_{//}$  and  $\kappa_{\perp}$  only differ by about three standard deviations. The average value of  $\nu$  is 0.53 which is only slightly smaller than the theoretical three-dimensional Ising value  $\nu = 0.640$  but much smaller than the three-dimensional Heisenberg value  $\nu = 0.702$ . It is to be noted that the theoretical value of  $\nu$  for the two-dimensional

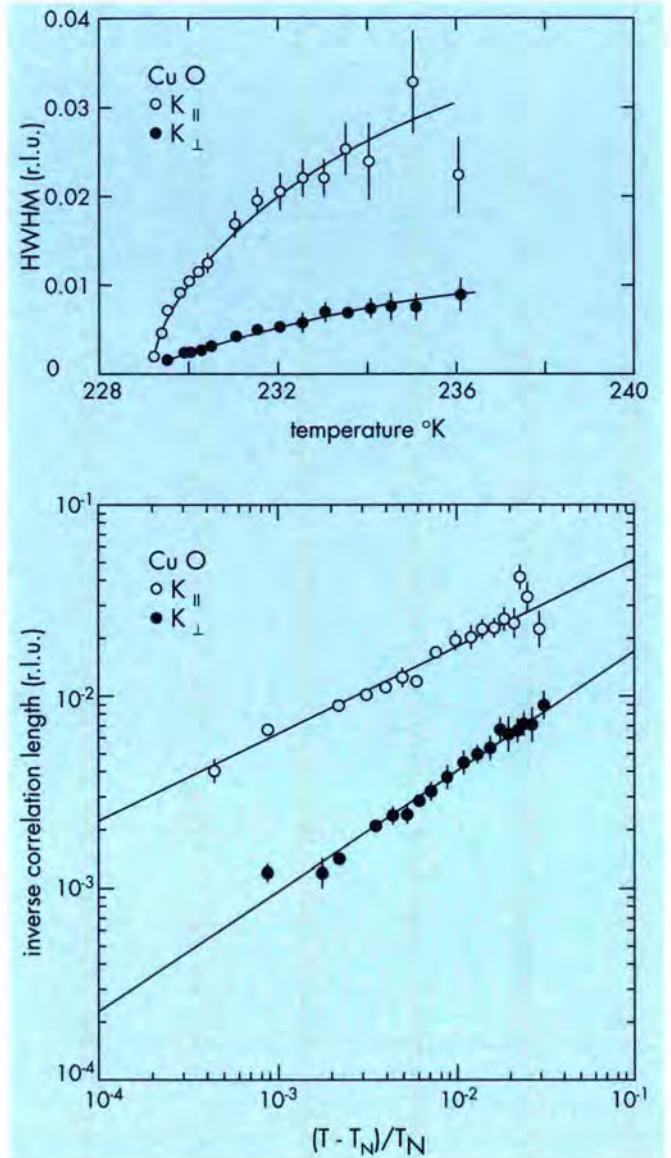

Fig. 20 Log-log plot of the inverse correlation lengths  $\kappa_{//}$  and  $\kappa_{\perp}$  of CuO along  $(1,0,-1)$  and  $(1,0,1)$ , respectively versus reduced temperature  $t = (T - T_N)/T_N$ .

Ising system is 1.0. Therefore, although the spin correlations in CuO are highly anisotropic, the critical exponent obtained from the inverse correlation lengths suggests that CuO is actually a three-dimensional magnetic system.

Fig. 21 shows the spin wave spectra of CuO along  $(\xi,0,-\xi)$  and  $(\xi,0,\xi)$  at  $T = 130$  K. The slopes of the acoustic branches are about  $600 \text{ meV}\text{\AA}$  and  $170 \text{ meV}\text{\AA}$  along  $(\xi,0,-\xi)$  and  $(\xi,0,\xi)$ , respectively. There exists a gap of about 1 meV in the excitation spectra at the zone centre. The spin wave spectra of CuO also indicate that CuO approximates more closely a three-dimensional system than to one of lower dimension. The large spin wave velocity along  $(\xi,0,-\xi)$

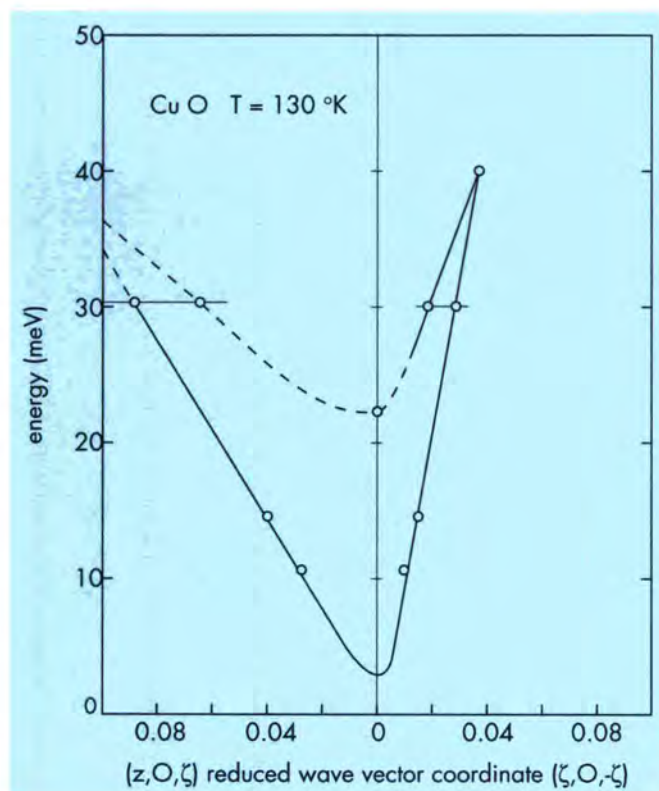

Figure 21: Magnetic excitation spectra of CuO along  $(\xi, 0, -\xi)$  and  $(\xi, 0, \xi)$  at  $T = 130$  K.

suggests a very strong magnetic interaction in the zig-zag O-Cu-O chain approximately parallel to this direction. It is this very strong magnetic interaction along  $(\xi, 0, -\xi)$  which must give rise to the long correlation lengths parallel to this direction above the Néel temperature and also the anomalous high temperature susceptibility.

Secretaries: T. Vogt

J. Rodriguez-Carvajal

## High Temperature Magnetisation in nickel

P.J. Brown

The exact nature of the magnetic carriers in the paramagnetic phases of ferromagnetic metals is still not completely understood. Precise measurements of magnetic neutron scattering by ferromagnets enable the spatial variation of the periodic magnetic moment to be determined with good accuracy. Such measurements provide an important check on electronic band structure calculations. At the present time the best self-consistent band structure calculations can give a good account of the ground state properties of the ferromagnetic 3d transition metals, but the same is not true for the finite temperature properties. Inelastic and quasi-elastic magnetic neutron scattering measurements show that strong correlations between nickel moments persist over distances of 20-30 Å well above the Curie temperature [2,3,4] indicating the existence in the paramagnetic phase of a local field direction, coherent over such distances, with respect to which the band-splitting takes place. At the higher temperatures there is evidence for longitudinal magnetic fluctuations in addition to the transverse fluctuations of the spin-waves. The magnetisation distribution is sensitive to changes in the band splitting both through the radial dependence of the form factor and its anisotropy. A recent study [5] of the variation of the elastic magnetic scattering and bulk magnetisation in nickel through the transition from ferromagnetism to paramagnetism has enabled changes in this distribution which take place as the magnetic fluctuations grow with temperature to be revealed.

The magnetisation distribution in nickel at room temperature was determined by Mook [1] using the polarised neutron technique. He found that the distribution in the metal could be modelled extremely accurately from a superposition of free atom magnetisations appropriate to  $\text{Ni}^{2+}$  ions superposed on a small uniform magnetisation of the opposite polarity. He obtained the best fit to his data with the magnetic form factor for  $\text{Ni}^{2+}$  ions obtained in the unrestricted Hartree Fock calculation of Watson and Freeman [6] with a spin moment of  $0.656 \mu_B$ , and a diffuse moment of  $-0.105 \mu_B$  per atom. The anisotropy of the form factor indicated that 81% of the 3d magnetisation had  $T_{2g}$  symmetry. The diffuse moment of opposite polarity to the magnetisation has been the subject of some controversy, it is most simply interpreted as a reverse polarisation of the 4s conduction band but this was not found in band structure calculations [7]. However, whatever the nature of the electrons which give rise to this feature, the experimental evidence shows that in ferromagnetic nickel the long wavelength fourier components of the magnetisation density have a polarization which is opposite to the applied field.

The new magnetisation and polarized neutron measurements [5] made at temperatures in the range 300 to 700K have been fitted to the same model. They show that there is very little change in the form factor as a function of temperature. This made it possible to use the measurements of the magnetic scattering in the 111 reflections, which were taken at 7° intervals in the temperature range 440-710K to obtain the total 3d moment as a function of temperature. Fig. 1 shows the temperature variation of the total 3d moment compared with the magnetic moment per nickel atom obtained from the bulk magnetisation in the same applied field (4.6T). The difference between these two values, which is the diffuse magnetisation  $\alpha$ , is negative at the lower temperatures, and its absolute magnitude falls with temperature reaching zero around the Curie point. This effect can be seen more clearly in Fig. 2 where the difference  $\alpha$  is plotted against temperature.  $\alpha$  can be seen to vary rapidly in the vicinity of the Curie temperature in a manner similar, but of opposite sign, to the spontaneous moment whose variation with temperature is shown in Fig. 3.

The observation that the form factor of nickel is almost independent of temperature is not unexpected. According to the UHF calculation [8] the spatial distribution of the majority and minority electrons is different, but this difference is not very great and taking it into account leads to a maximum difference in the form factor for  $\text{Ni}^{2+}$  of only some 2% which occurs at  $\sin\theta/\lambda=0.3 \text{ \AA}^{-1}$ . Although this difference would increase if the polarisation of the wave-functions remained the same while the numbers of majority and minority electrons became more equal as the result of longitudinal

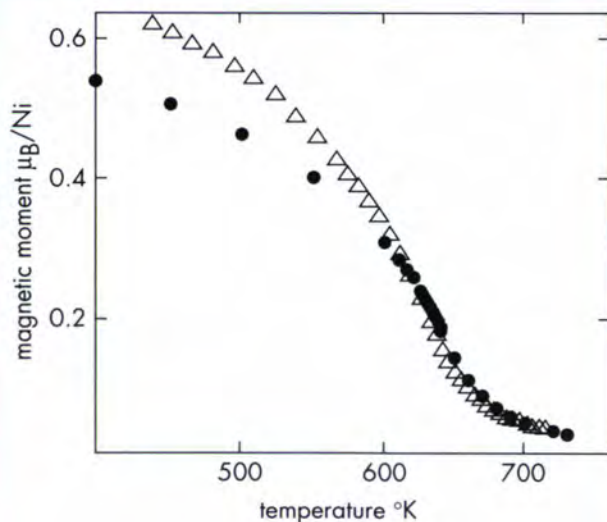

Figure 1: Temperature dependence of the magnetisation of nickel in an applied field of 4.6T. The circles show the bulk magnetisation and the triangles the 3d magnetisation deduced from the magnetic scattering in the 111 reflection.

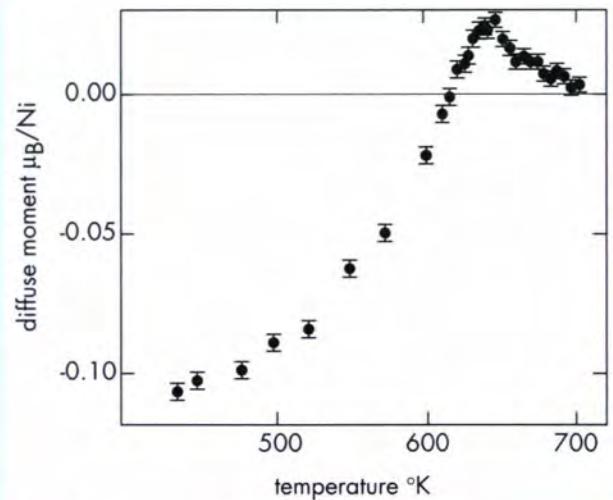

Figure 2: Temperature dependence of the diffuse magnetisation in nickel in an applied field of 4.6T in the vicinity of the Curie temperature.

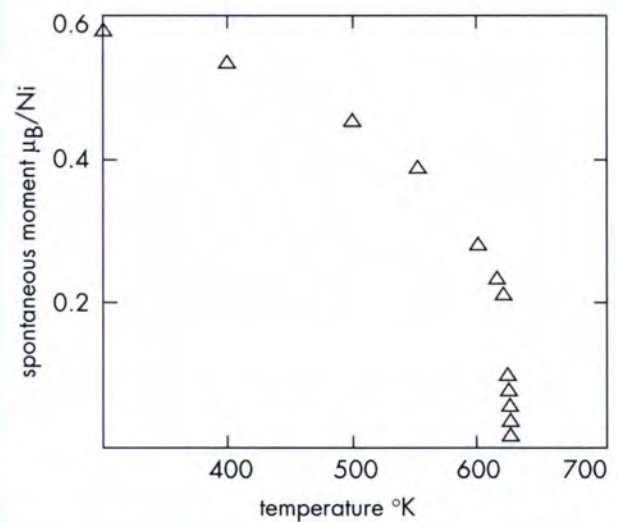

Figure 3: Temperature dependence of the spontaneous magnetisation in nickel derived from bulk magnetometry.

spin-fluctuations, it is much more likely that the polarisation decreases in proportion to the magnetic moment leaving the form-factor essentially unchanged. Much more significant is the observation that the negative diffuse moment disappears at the Curie temperature. This shows that such polarisation is the result of long range magnetic order and can not be induced either by an applied field or by the short range fluctuating local fields occurring in the paramagnetic state [4]. One may also speculate as to whether the small expansion of the form factor observed in the highest temperature data may not have its origin in the same process. The conclusion which is obtained from these measurements is that the magnetisation which can be aligned by an external field

in the paramagnetic state is spatially more compact than the spontaneous magnetisation: suggesting that the longer wavelength components of the magnetisation are less stable to thermally induced spin fluctuations than are those more closely localised on individual atoms.

#### *References*

- [1] Mook H.A., Phys. Rev. **148** (1966) 495
- [2] Mook H.A. and Lynn J.W.,  
Phys. Rev. B **23** (1981) 198
- [3] Steinsvoll O., Majkrzak C.F., Shirane G.  
and Wicksted J., Phys. Rev. B **30** (1984) 2377
- [4] Brown P.J., Capellman H., Deportes J., Givord D.,  
Johnson S.M. and Ziebeck K.R.A.,  
Journal de Physique **47** (1986) 491
- [5] Brown P.J., Deportes J. and Ziebeck K.R.A.,  
J. Phys. I France **1** (1991) 1529
- [6] Watson R.E. and Freeman A.J.,  
Acta Cryst. **14**, (1961) 27
- [7] Hodges L., Ehrenreich H. and Lang N.D.,  
Phys. Rev. **152** (1966) 505
- [8] Watson R.E. and Freeman A.J.,  
Phys. Rev. **120**, (1960) 1125

## Liquids, Disordered Materials and Metal Physics

### Members of the College

K. Al Usta	C. Janot
E. Amalric	G. Kearley
L. Andersen	C. Lartigue
I. Anderson	H.J. Lauter
T. Baumbach	J.F. Legrand
J.P. Beaufiles	A. Lied
M. Bée	P. Lindner
M. Boudard	A. Magerl
P. Chieux	J.L. Martinez
J. Cook	H. Mutka
E. Davies	L. Needham
J. Desplat	R. Oeser
A.J. Dianoux	W. Petry
D. Dubos	O. Randl
B. Fåk	F. Rieutord
B. Farago	C. Ritter
B. Frick	O. Schaerpf
F. Güthoff	J.-B. Suck
A. Heidemann	J. Trampenau
A. Heiming	J. Wuttke
I. Howell	

### Summary

For obvious reasons the activities of the College have concentrated in 1991 mainly on data evaluation. The contributions to a number of international conferences held in 1991 show the outstanding possibilities of the ILL, as well as the scientific efforts of both users and College members. Several conferences concerning College 6 were held in 1991 e.g.: ICNS'91, and conferences concerning special subjects, like aerogels, relaxation in disordered systems, structure and dynamics of non-crystalline materials, metal physics or hydrogen in metals. The following report gives a short insight into the manifold activities and hopefully can show that for many of these experiments high quality data were necessary. Often high resolution in energy and/or  $Q$  were required, with excellent background conditions. We all know that these requirements usually result in a reduced neutron flux and thus many of these experiments could only have been carried out at the ILL.

### Scientific Trends and Highlights in 1991

#### Gases

Three-body effects in gaseous Argon were investigated on D4 (Magli, Fredrikze, Chieux, Barocchi). One of the best ways to understand the nature and behaviour of three-body forces is to observe the virial expansion of microscopic quantities in experiments on low density gases. An accurate study of the density dependence of the static structure factor

in low density  $^{36}\text{Ar}$  gas at 140 K has given the three-body contribution in the linear density expansion of  $C(k)$  (Fourier transform of the direct correlation function). For  $3 < k < 100 \text{ nm}^{-1}$  the experimental results agree with theoretical calculations based on a pair potential and the Axibrod-Teller three-body potential, in some cases modified for short range effects; for  $k < 3 \text{ nm}^{-1}$  the neutron diffraction data show a behaviour significantly different with respect to theoretical predictions (see Fig. 1).

#### Liquids - from the quantum liquid $^4\text{He}$ to polymeric sulphur

**Liquid Helium 4** is the only fluid which exhibits a really sharp excitation above a momentum transfer of  $1 \text{ \AA}^{-1}$  and only below the  $\lambda$  temperature  $T_\lambda = 2.14 \text{ K}$  (see Fig. 2). At this temperature a macroscopic fraction of the atoms condenses into the zero momentum state, suggesting that these excitations might be connected to the Bose broken symmetry, an assumption which still remains unproven. At low temperatures the  $S(Q, \omega)$  for liquid  $^4\text{He}$  shows below  $Q = 3 \text{ \AA}^{-1}$  a single sharp peak, which follows the well-known phonon-maxon-rotor dispersion curve and a broad excitation spectrum in energy, usually attributed to multiphonon excitations. In a recent interpretation by Glyde and Griffin the low  $Q$ -phonon and the maxon-rotor excitation are ascribed to different excitation branches, which are coupled through the presence of the Bose condensate into a single dispersion curve, as is observed. In this picture the phonon is a zero sound mode as observed in classic liquids and it does not change qualitatively when passing  $T_\lambda$ . The intensity of the maxon-rotor excitation, however, should depend on the Bose condensate fraction and therefore vanish at  $T_\lambda$ . The temperature dependence should then be very dependent on  $Q$ .

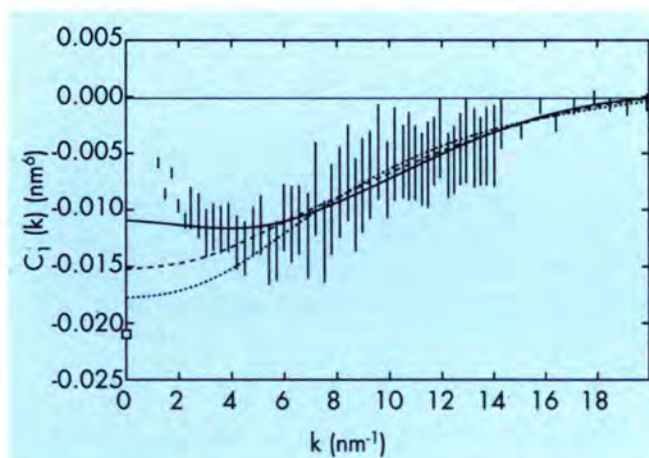

Fig. 1:  $C_1(k)$  from linear density expansion of  $C(k)$  (error bars) and as calculated from Barker-Fisher-Watts pair potential alone (full line) or including the Axibrod-Teller three-body potential (dotted line) or its modification by Loubeyre (dashed line). The  $k = 0$  value (square) has been calculated by means of the equation of state for Argon.

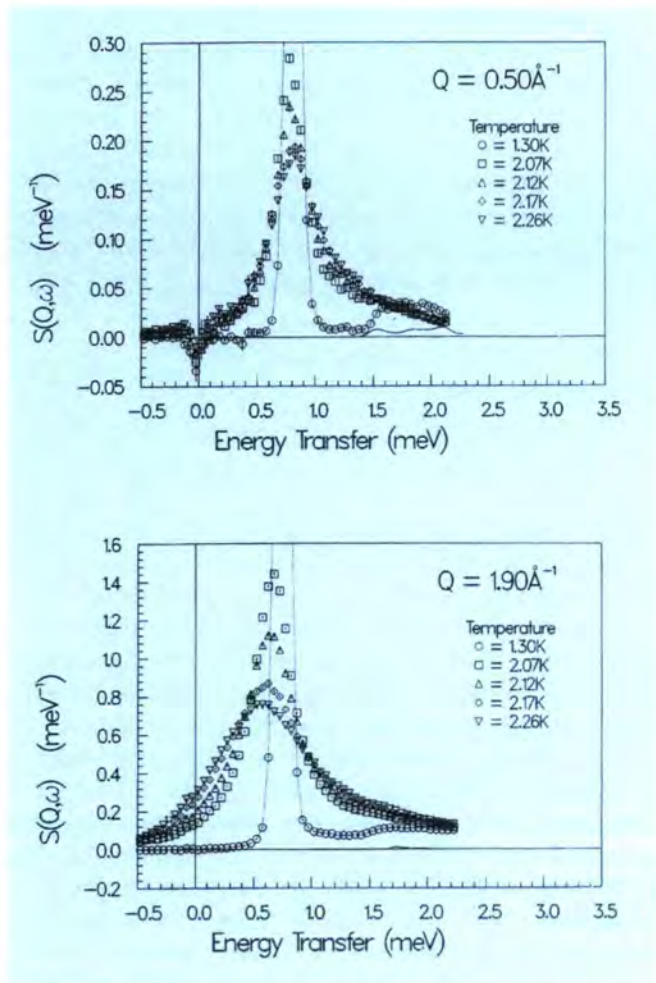

Fig. 2 : Temperature dependence of  $S(Q, \omega)$  for liquid  $^4\text{He}$  near  $T_\lambda$  and two different  $Q$ -values : a) at  $Q = 0.5 \text{ \AA}^{-1}$  in the phonon region, b) at  $Q = 1.9 \text{ \AA}^{-1}$  at the roton minimum. The solid curve presents the calculated multiple scattering contribution. (IN6-data).

The aim of a measuring series, recently started on IN6 (Andersen, Stirling, Scherm, Stunault, Fåk, Godfrin, Dianoux) around  $T_\lambda$  in liquid  $^4\text{He}$  is an overall examination of these excitations with high precision. The experiment was carried out with good energy resolution ( $\text{FWHM} = 125 \text{ \mu eV}$ ) in the  $Q$ -range between  $0.3 \text{ \AA}^{-1}$  and  $2.1 \text{ \AA}^{-1}$ . The sophisticated experiment, only possible with the high flux on IN6, did indeed show that the temperature dependence is changing sensitively with  $Q$ , the phonon remaining a well defined excitation above  $T_\lambda$ , while the maxon-roton excitations change abruptly at  $T_\lambda$ . Fig. 3 shows a comparison of the dynamic structure factors, measured at two different  $Q$ -values.

In liquid deuterium, half a degree above the melting temperature, collective excitations were found, up to a momentum transfer of  $3.8 \text{ \AA}^{-1}$  (Bermejo, Martinez, Martin-Marero, Mompean, Garcia-Hernandez, Chahid). Remarkably, the dispersion curves of this simple non-quantum liquid show similarity to the dispersion curve of liquid  $^4\text{He}$  in the normal liquid phase, showing up a well defined minimum at  $Q_{\text{min}} = 2.08 \text{ \AA}^{-1}$ . Model calculations based on damped harmonic oscillator behaviour can reproduce the observed spectra and the minimum in the dispersion curve can be explained by  $\Omega_q = \hbar^2(Q - Q_{\text{min}})^2 / 2M_{\text{eff}} + \Delta$ , by analogy to the dispersion curve minimum in normal liquid  $^4\text{He}$ . ( $Q_{\text{min}} = 2.085 \text{ \AA}^{-1}$ , gap  $\Delta = 30.06 \text{ K}$ , eff. mass  $= 0.0054 M_{\text{D}_2}$ ). The calculated phonon phase velocities show up a positive anomalous dispersion with a maximum near  $0.5 \text{ \AA}^{-1}$ , corresponding to a 30% deviation from the adiabatic sound velocity. This remarkable analogy to normal liquid  $^4\text{He}$  calls for a further systematic study as a function of temperature and pressure.

Evidence for magnetic excitations in liquid oxygen is found (Martinez, Bermejo, Garcia-Hernandez, Mompean) by new experiments on IN8. Liquid oxygen, measured at a pressure of 2bars and at 55 K ( $T_m = 54.4 \text{ K}$ ) gets its magnetic properties from exchange interaction due to a direct overlap of orbitals, and thus a strong coupling of structural, orientational and magnetic properties is expected. Solid oxygen exhibits three different crystalline phases: an antiferromagnetic low temperature  $\alpha$ -phase, and two phases ( $\beta, \gamma$ ), with probably antiferromagnetic short range order. In the liquid, earlier experiments on D5 (Deraman, Dore, Schweizer) using polarized neutrons but integrating in energy led already to the assumption, that the spins of neighbouring molecules have the tendency to align antiparallel even at  $T = 4 * T_{\text{NeeI}}$ . The new IN8 results, using unpolarized neutrons, but a much better energy resolution of  $0.5 \text{ THz}$  reveal for the dynamic structure factor a peak near the main peak of the static structure factor, but also a second weaker peak at about half the  $Q$ -value, indicative of antiferromagnetic ordering. From the width of the curves a correlation length of only  $5 \text{ \AA}$  is deduced. The persistence of the antiferromagnetic correlations even in the liquid presents another hint at the non random short range order in liquids.

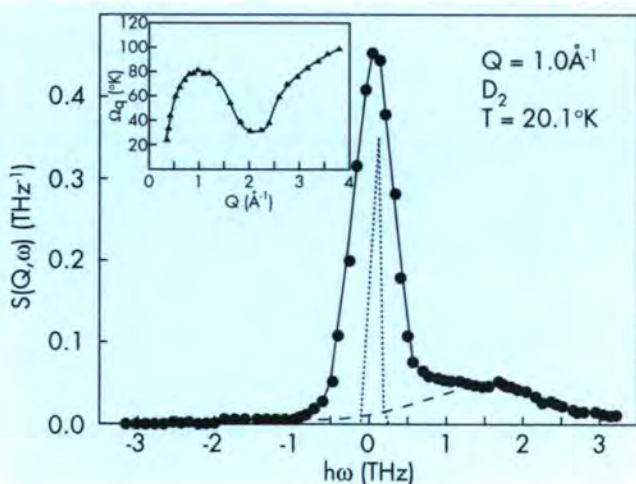

Fig. 3: Dynamical structure factor of liquid deuterium measured on IN8. The observed inelastic excitation shows a dispersion behaviour similar to normal liquid  $^4\text{He}$  (see insert).

**The icosahedral order in quasi-crystal forming liquids** was investigated using D4 (Maret, Chieux, Dubois, Pasturel). The discovery of quasicrystalline phases in AlMn alloys has generated a renewal of interest in the possible occurrence of icosahedral order in liquid alloys. During the last few years, topological and chemical short range orders have been investigated in  $\text{Al}_{80}\text{Mn}_{20}$  and  $\text{Al}_{80}\text{Ni}_{20}$  liquid alloys through the accurate determination of the partial pair correlation functions by Neutron Diffraction using either isomorphous substitution (between Mn atoms and the  $\sigma$ -FeCr mixture) or Ni isotopic substitution. Several  $\text{Al}_{1-x}\text{M}_x$  ( $M = \text{Mn}$  or  $\sigma$ -FeCr) liquid alloys were investigated at compositions around  $x = 0.20$ , i.e. in the quasi-crystal forming range or outside it ( $x = 0.4$ ). Although it is still difficult to draw firm conclusions, the results point out traces of icosahedral order in the  $S_{NN}$  functions of  $\text{Al}_x\text{M}_{1-x}$  which are absent from liquid  $\text{Al}_{80}\text{Ni}_{20}$  which does not form quasi-crystals. Despite the fact that the alloy composition of  $\text{Al}_{60}\text{M}_{40}$  falls outside the quasi-crystal forming composition range, this alloy exhibits a tendency towards icosahedral ordering as  $\text{Al}_{80}\text{M}_{20}$ , the strength of the heteroatomic interactions being similar at both concentrations but the homoatomic first distances being shortened in  $\text{Al}_{60}\text{M}_{40}$ . Molecular dynamics simulation using partial pair potentials extracted from the data is confirming these findings.

An example of a quite complex liquid, which is not yet well understood is **liquid sulphur**. It exhibits a polymerisation transition at  $T=160^\circ\text{C}$ , with a drastic increase in viscosity by several orders of magnitude. Sulphur is thought to present a molecular liquid between  $120^\circ\text{C}$  and  $160^\circ\text{C}$ , forming mainly  $S_8$  rings. Above  $T=160^\circ\text{C}$  sulphur changes to a polymeric liquid, as the  $S_8$  rings open and form long polymer chains. Following structural investigations the dynamical behaviour of sulphur between  $125^\circ\text{C}$  and  $400^\circ\text{C}$  was studied on IN6 (Bellissent, Dianoux). The preliminary data evaluation shows that quasi-elastic intensity exists, which is composed of two components. A fast relaxation component (about  $400\mu\text{eV}$  width  $\sim 100\text{GHz}$ ), which is probably due to a reorientation of the  $S_8$  molecules and a slower ( $10\text{-}100\mu\text{eV} \sim 2.5\text{-}25\text{GHz}$ ) centre of mass diffusion of the  $S_8$  rings. The slower component shows up "de Gennes narrowing" and is dependent on temperature. Furthermore, the vibrational density of states of liquid sulphur is well structured and not too much different from the sulphur powder spectrum, indicating that the local structures are probably similar.

### The structure of glasses

The structure of **silicate glass** of approximately calcium metasilicate composition having been established with considerable precision, including the Ca-Ca distribution, the effects of replacing half of the Ca in the metasilicate glass by Mg and of adding Ca to the Lithium disilicate were now examined (D4, Gaskell, Eckersley, Barnes, Chieux). In the latter case, the number of nearest neighbour oxygens

decreases from four in the undoped Lithium disilicate to three in the mixed cation glass. On the other hand, when Mg is added to the calcium metasilicate, no changes are found in the environment of Ca which is contrary to what occurs in the crystalline phase. These results are currently discussed in terms of models for the structure of glasses and the mixed alkali effect.

The prepeak discovered in the Q-range  $0.5\text{-}0.9\text{\AA}^{-1}$  from  $S(Q)$  measurements of the **phosphate glass  $\text{AgPO}_3\text{-AgX}$**  ( $X = \text{I, Br, Cl}$ ) has been studied using Cl isotopic substitution (D4, Rousselot, Tachez, Malugani, Chieux). The intensity of the prepeak is correlated to the scattering contrast between  $\text{AgPO}_3$  and  $\text{AgX}$ , suggesting an intermediate ordering of  $\text{AgPO}_3$  and  $\text{AgX}$  microdomains with a repeating distance  $\sim 10\text{\AA}$ . One of the models proposed is made of  $\text{PO}_3$  chains separated by a "connective tissue" of disordered  $\text{AgX}$ .

The local environment of a metallic atom in amorphous  **$\text{Pr}_{16.7}\text{Ni}_{83.3}$**  was tested using **crystal electric field excitations as a local probe**. In trying to describe the measured spectrum of magnetically scattered neutrons from amorphous  $\text{Pr}_{16.7}\text{Ni}_{83.3}$ , a model of a strongly distorted crystal has been devised, where the randomization of the atomic positions was achieved by introducing a distribution of bond lengths and of bond angles (tetragonal distortion of the hexagonal local symmetry) for the atoms around the  $\text{Pr}^{3+}$  ions. This model describes reasonably well the observed magnetic dynamic structure factor, which is smoothly decreasing with increasing energy transfer. However, this model predicts the existence of a broad crystal field peak near  $1\text{meV}$  in the strongly distorted crystal, which was not resolved in the first experiment done on IN4 (see Ann. Rep. 90). In the meantime, a broad peak was in

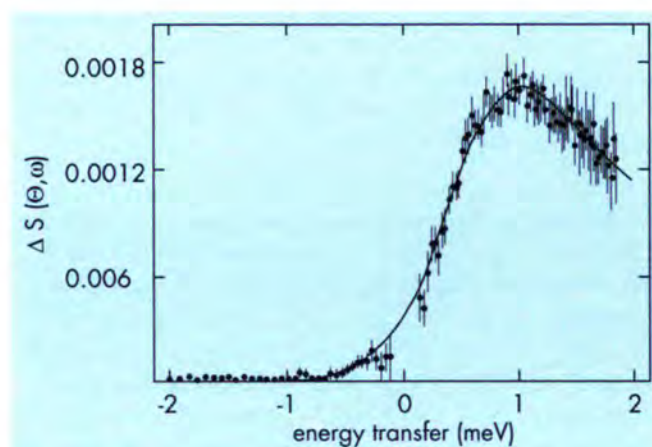

Fig. 4 : Difference of the dynamic structure factors  $S(Q, \omega)$  measured at 2 K and fixed scattering angle  $\theta$  on IN6 of amorphous  $\text{Pr}_{16.7}\text{Ni}_{83.3}$  and of amorphous (non-magnetic)  $\text{La}_{16.7}\text{Ni}_{83.3}$ . The values in the centre of the elastic peak have been omitted due to their huge error bars. The line corresponds to a fit of the experimental data by a Lorentzian (including the temperature factor) centred near  $0.6\text{meV}$ .

fact found next to the elastic line in a most recent experiment done on IN6 with a resolution of 125  $\mu\text{eV}$ , comparing  $\text{Pr}_{16.7}\text{Ni}_{83.3}$  and the non-magnetic counterpart  $\text{La}_{16.7}\text{Ni}_{83.3}$  (Alekseev, Suck, Lazuhov, Orlov). After subtraction of the phonon part, the remaining magnetic dynamic structure factor  $S(Q, \omega)$  (see Fig. 4) was fitted with different model functions (inelastic peak, quasi-elastic peak shifted by the temperature factor, inelastic peak plus quasi-elastic peak). It was concluded that this peak in fact represents an inelastic excitation centred near 1 meV. According to the distorted crystal model this "crystal" field peak is caused directly by the tetragonal distortion of the crystalline symmetry (local geometry or bond angles), which removes the J-multiplet degeneracy and allows the transitions between ground and low lying singlet levels with a high transition probability.

### Vibrational properties of glasses

Glasses are known to show unusual vibrational behaviour at low frequencies. The study of the vibrational properties of glasses requires not only time-of-flight instruments, which are the usual spectrometers for this type of study, but increasingly also complementary information from triple-axis spectrometers or even from backscattering spectrometers.

Collective excitations in the **molecular glass of deuterated methanol** ( $\text{CD}_3\text{OD}-6\%\text{D}_2\text{O}$ ) have been studied on the triple axis spectrometer IN8 and on the time-of-flight instrument IN6 (Bermejo, Martinez, Garcia-Hernandez, Martin, Mompean, Alonso, Howells). The measurements reveal well defined inelastic peaks with a dispersion behaviour similar to metallic glasses. The authors deduce from their data that the observed low frequency excitations around 6meV are not purely of acoustic nature, but coupled to a broad band of additional modes around 22 meV. The calculated vibrational density of states shows an abrupt change above a temperature of  $T=10\text{K}$ , which again might be explained by a coupling between sound waves and localized excitations.

The vibrational density of states (VDOS) of **chalcogenide glasses**  $\text{Se}_x\text{Te}_{1-x}$  has been investigated on IN6 and IN4 (Needham, Rosenberg, Dianoux, Murani) in the temperature range from 70 K to 300 K. It was found that the VDOS for chalcogenide glasses shows up a similar low frequency behaviour as observed in a number of amorphous materials of different type, it breaks away from a  $g(\omega) \propto \omega^2$  dependence above about 1meV, changing to a higher  $\omega$ -dependence. This was confirmed by comparing the amorphous and crystalline form of  $\text{Se}_x\text{Te}_{1-x}$  thus supporting the view that the break-away is indeed a property of the amorphous material. In addition to gaining information about the low-energy behaviour of the density of states, the IN6 data revealed the presence of excitations up to 35 meV in both the amorphous and crystalline forms of the samples. These excitations have been identified in terms of the

torsional, librational, bending and stretching modes predicted for crystalline Se and are very similar for both the amorphous and crystalline forms of the samples. The contribution to the total density of states for each mode is in good agreement with the predictions for the Se model. The interpretation of the data in this way has been supported by measurements on IN4, using an incident energy of 115 meV, where no excitational modes between 35 meV and 100 meV were found.

An ongoing and very interesting subject presents the vibrational properties of **silica aerogels**. These fascinating materials, which may become of technological importance (e.g. for insulating materials due to their unusual thermal properties) owe their extraordinary physical properties to their porous structure. Fantastically low densities can be achieved by supercritical drying of the gels (down to about 100  $\text{kg/m}^3$ ) From SANS a self-similar or fractal structure may then be observed over more than one decade in  $Q$ . Theories predict for these systems a scaling behaviour of the vibrational density of states  $g(\omega) \propto \omega^{d-1}$ , above  $\omega_c$ , the crossover frequency from phonon to fracton behaviour,  $d$  being the so-called spectral dimension. Neutron scattering and especially the instruments for highest energy resolution at the ILL have proved to be an ideal tool for the study of these phenomena. Without going into detail it must be mentioned that neutron scattering experiments could find a fracton-phonon crossover (Vacher, Courtens et al; Reichenauer, Conrad, Buchenau et al). The recent experiments then mainly aimed to investigate structurally modified aerogels, being either prepared with different densities or being densified by heat treatments. A change of the fractal persistence length is thus expected to change the vibrational properties in the low frequency range (Vacher, Courtens, Coddens, Heidemann, on IN13 and IN10). On densified silica aerogels glassy soft vibrational modes (Reichenauer, Buchenau, Monkenbusch, Sosnowska, Frick on IN6) above 10 GHz were found and identified as coupled  $\text{SiO}_4$  tetrahedra librations, similar to those observed earlier in amorphous silica.

### The liquid-glass transition

Experiments investigating the liquid-glass transition were still numerous, in the focus of interest being the comparison with mode-coupling (MC-) theory. Having shown that qualitatively neutron scattering experiments are in agreement with predictions of the MC-theory (see Annual Report '90), the experiments have become now more difficult. A quantitative comparison of the critical exponents of the  $\alpha$ - and  $\beta$ -relaxation has to be investigated. This asks for high accuracy data and a wide dynamical range. Furthermore, a connection to NMR and dielectric experiments must be tried.

Neutron backscattering and spin-echo experiments on the van-der-Waals glass **orthoterphenyl (OTP)** had shown agreement with several predictions of the MC-theory

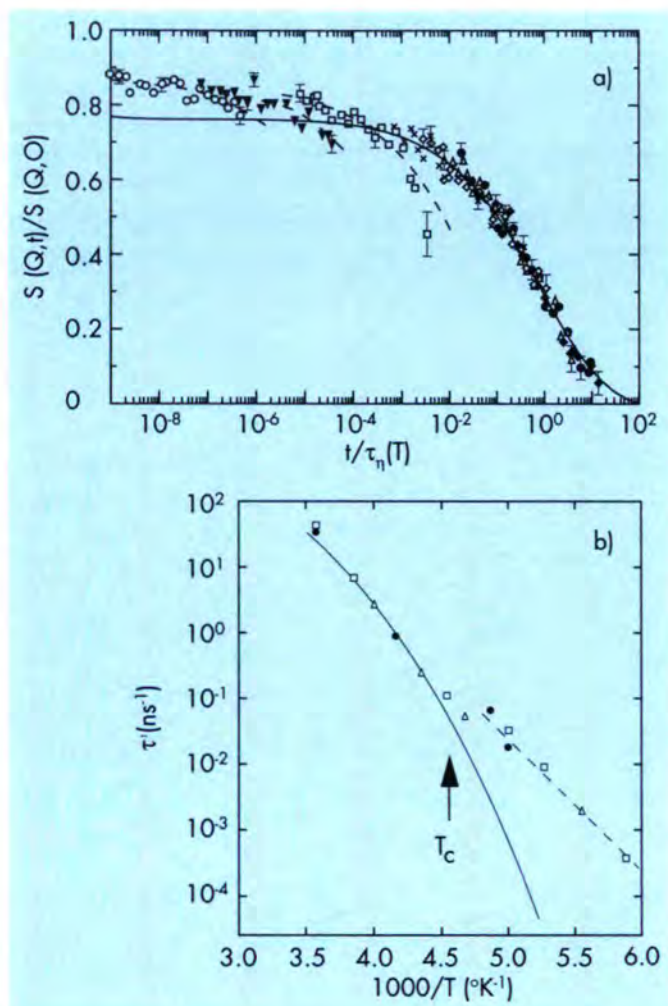

Fig. 5a: Intermediate scattering function of polybutadiene plotted on a rescaled time axis  $t/\tau_{\eta}(T)$ .  $\tau_{\eta}(T)$  represents the temperature dependent relaxation time deduced from viscosity measurements. The data are taken on IN11 at  $Q = 1.88 \text{ \AA}^{-1}$  and at different temperatures (  $\blacklozenge$  280 K,  $\bullet$  260 K,  $\Delta$  250 K,  $\diamond$  240 K,  $\times$  230 K,  $\square$  205 K,  $\blacktriangledown$  190 K,  $\circ$  180 K  $\approx T_g$ ;  $T_c = 216$  K). the continuous line is the resulting master function above  $T = 220$  K, dashed line is the fit result for stretched exponential with exponent 0.37.

Fig. 5b: Arrhenius representation of the relaxation rates. The continuous line corresponds to the time scale as given by the viscosity. The dashed line indicates the measured low temperature Arrhenius behaviour.

(see Annual Report 1990). The inspection of elastic scans on IN13 using isotopically substituted OTP confirmed that the a priori assumption was justified, that intramolecular dynamics is negligible for OTP. (Debus, Zimmermann, Bartsch, Fujara, Kiebel, Petry, Sillescu).

A decoupling of macroscopic and microscopic time scales was observed by spin-echo experiments on **amorphous polybutadiene** (Richter, Zorn, Farago, Frick, Fetters) at a  $Q$ -value above the first structure factor peak. Whereas at higher temperatures the intermediate scattering function scales with viscosity data, at lower temperatures

drastic deviations from scaling occur (see Fig. 5). The shape of the relaxation curves in the temperature range where the deviations are observed is different from what one would expect for the  $\beta$ -relaxation. Furthermore, the temperature dependent spectral weight of the observed relaxation agrees with predictions of the mode coupling theory for the  $\alpha$ -relaxation. The authors attribute the observed deviation from scaling to the  $\alpha$ -process, persisting via the onset of hopping processes below  $T_c$  and thus removing the ideally sharp glass transition. This poses the question as to the relation between the observed behaviour and the dielectric  $\beta$ -relaxation.

The phase diagram of the **glass-forming solutions LiCl $\cdot$ R $\cdot$ H $_2$ O** has been widely investigated using neutron scattering as well as other classical techniques. For the solutions with  $R=6$  (and  $R=4$ ), there is no crystallization of stable hydrates upon cooling, but the viscosity diverges around 142 K. The structural relaxation of this glass-forming system has been analyzed using neutron spin-echo at the first maximum of the structure factor ( $Q_1=1.9 \text{ \AA}^{-1}$ ) and in the temperature range from 257 K to 167 K. For each temperature  $T$  the intermediate scattering function displays a Kohlrausch-type behaviour:  $S(Q_1,t)_T = S(Q_1,0)_T \exp[-(t/\tau(T))^b]$  with a mean relaxation time  $\tau(T)$  which is confirmed to be proportional to the (hydrodynamic) viscosity of the solution  $\eta(T)$ . However, contrary to what was observed previously in other glass-forming systems, the NSE data do not merge into a single "master-curve" after rescaling by the viscosity. The authors explain this by the  $\beta$  exponent of the Kohlrausch law which appears to decrease from 257 K ( $b = 0.8$ ) to 188 K ( $b = 0.55$ ). This might be interpreted by a significant broadening of the distribution of relaxation times when the system approaches the glass transition.

Contrary to the later observations, incoherent quasi-elastic neutron scattering experiments on IN10 and IN13 on **polyvinylchloride, polyvinylmethylether and Phenoxy** in the  $\alpha$ -relaxation range could be explained by a temperature- and  $Q$ -independent spectral shape, the relaxation being of stretched exponential type. (Colmenero, Alegria, Arbe, Frick). The relaxation times show a dependence on temperature and  $Q$ . Whereas the temperature dependence is found to be close to Vogel-Fulcher type, the  $Q$ -dependence follows approximately power laws ( $\tau(Q,T) \sim Q^n$ ). The authors observe that an extreme deviation from simple exponential relaxation is connected to an extreme power in  $Q$ , the product  $n\beta \approx 2$  being roughly constant. Dielectric and NMR data support these observations.

### Metal Physics

The local displacement field around **Co and Nb solutes** in the  $\omega$ -phase forming **bcc-Zr** was investigated on D7 (Heiming, Petry, Vogl, Trampenau, Schober, Chevrier, Schärpf) using in situ grown single crystals, which have to be kept at high temperatures for the experiment (see earlier annual reports). The motivation for this work was to find out

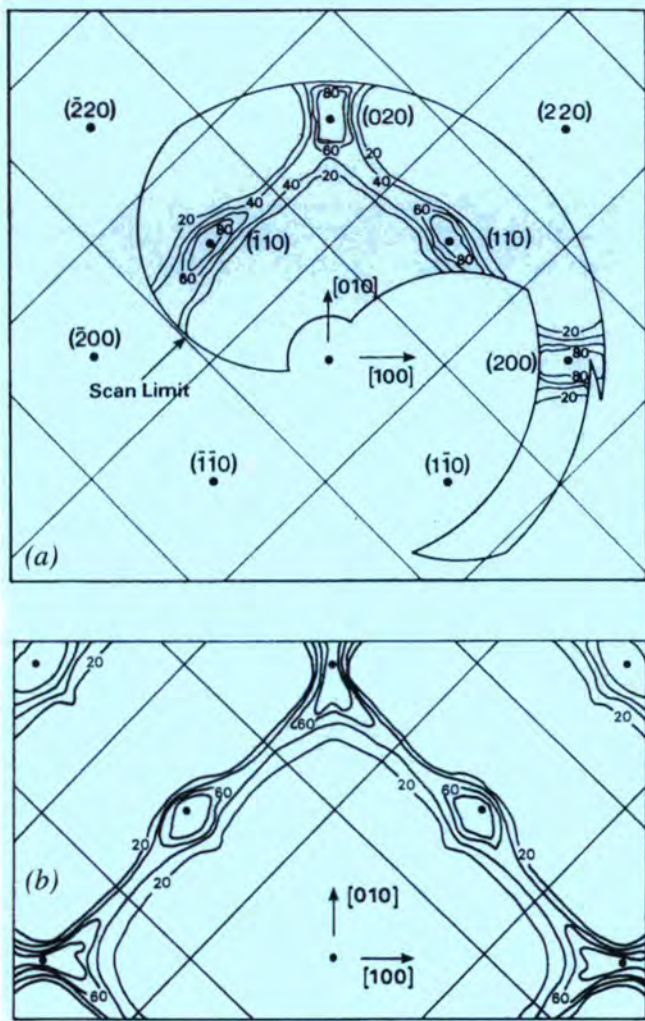

Fig. 6:  $Zr_{0.985}Co_{0.015}$ : a - Diffuse elastic intensity distribution in the (001) plane at  $1000^{\circ}C$  in  $mbarn/sterad$ . Measurements on TOF spectrometer D7. The increasingly strong intensities close to the Bragg reflexions are not shown. b - Results of Kanzaki model calculations.

whether, localized around the solute atoms, precursors of new phases exist in thermodynamical equilibrium. The small size of the Co-atoms in comparison to Zr causes a large perturbation of the matrix. The alloy  $Zr_{0.985}Co_{0.015}$  was therefore chosen. The system  $Zr_{0.92}Nb_{0.08}$  was taken as a reference. Special emphasis has been put on the correct separation of the thermal diffuse scattering and of the scattering of inelastic origin reaching down to zero energy transfer. This is the first time that diffuse intensity distribution has been investigated in different reciprocal planes at high temperatures in bcc-Zr alloys. The comparison of the experimental results with model calculation shows that Co as well as Nb atoms cause radial symmetric displacement fields (see Fig. 6). The authors conclude that major differences in the origin of diffuse intensities between quenched Zr alloys and samples held at high temperatures exist. A considerable volume fraction of

the  $\omega$ -phase will be obtained by quenching, due to the creation of internal strains. But keeping the sample at high temperatures no preferred direction for the displacements around the solute atom in the bcc-lattice is found. These results allow those models to be discarded for the very fast diffusion of Co in  $\beta$ -Zr, which are based on the assumption that a majority of Cobalt atoms resides on the interstitial lattice.

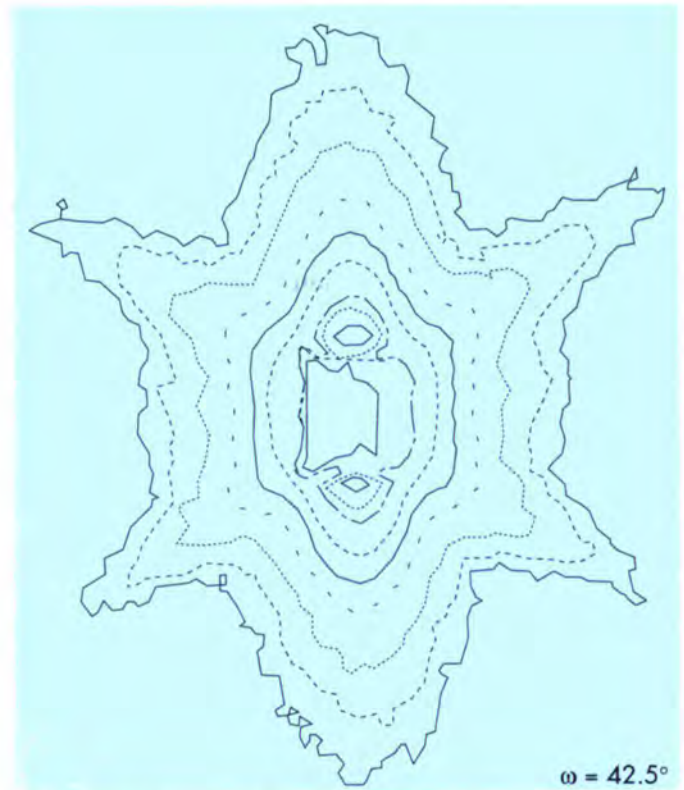

Fig. 7a: SANS pattern (D11) from a AM1 crystal annealed for 128 hours at  $1050^{\circ}C$ . The 110 axis of a crystal is set parallel to the incoming beam.

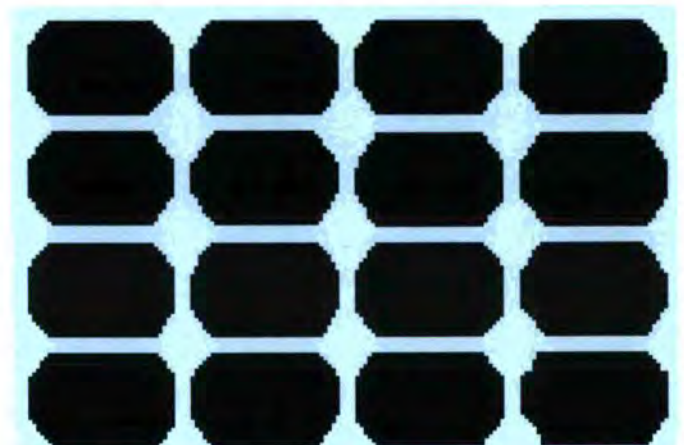

Fig. 7b: Part of the model image. Here precipitate shape is rectangular since we are considering the 110 plane.

The structures of **nanocrystalline materials** are unique since grain boundaries comprise a significant fraction of the total volume. Therefore it is expected that some physical properties are different from those in polycrystalline samples due to the smaller grain sizes in nanocrystalline materials. Moreover the residual porosity will influence the mechanical properties. Wagner, Averbach, Hahn, Petry and Wiedenmann have employed SANS for a quantitative measurement of the pore size distribution, taking into account that grain boundaries and surface roughness contribute considerably to the measured background. They have investigated the nanophase of  $\text{TiO}_2$  ceramics compacted at different temperatures. The pore size distribution of the samples, which were compacted at room temperature ranged from 3 to 30 nm, and the pores comprise 38% of the sample. Compaction at higher temperatures (up to  $550^\circ\text{C}$ ) reduces the pore volume to 8% and narrows the size distribution of pores.

**Magnetic properties in nanophase iron (n-Fe)** were studied by SANS on D11 (Wagner, Wiedenmann, Böni, Birringer, Geibel, Petry). Anisotropic evaluation of the 2 dim.- SANS data allowed separation of nuclear and magnetic scattering contributions and the quantitative evaluation of the magnetic correlation lengths and their relation to the microstructure of grains and grain boundaries. The measurements support the microstructural model of ferromagnetic grains and of weakly, or non-magnetic interfaces in n-Fe, the interfaces being occupied by about 40% with respect to the bulk density. In the absence of an external magnetic field the magnetic correlations extend much further than these interfaces and up to about several hundred grains. They have an average preferential orientation, which results in an additional magnetic small angle scattering intensity. This intensity is reduced by 70 - 90 % in a weak external field of 1.5 KOe, being insufficient to align the grains collectively, but to disturb considerably the long range magnetic correlations.

A morphological study of precipitates of single crystals of **AM1 Ni based super alloys** has been undertaken, analysing small angle neutron scattering patterns obtained on D11 (Bellet, Royer, Bastie). Supplementary transmission electron microscope photographs show that the precipitates are in a cuboidal shape. To interpret the SANS data the Fourier transforms of the electron microscope photographs and Fourier transforms of model images have been performed with the help of *Optilab*, an image processing software for Macintosh. This made it possible to study the influence of the precipitate shape and of their disorder in shape, orientation or size onto the SANS patterns. For example, the star shape of some D11 patterns (Fig. 7a) is found to be due to facets in the edges of the precipitate cubes as shown in figures 7b and 7c.

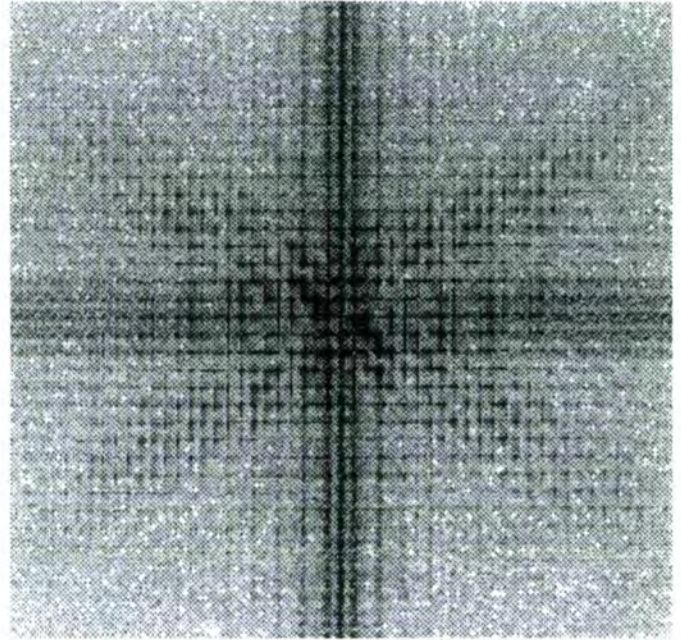

Fig. 7c: Fourier pattern of the model image as obtained with the help of *Optilab*.

**LAWRIE:**

**Low angle well resolved inelastic experiments**

**Jens-Boie Suck**

Periodic crystals have a reciprocal lattice with well defined Brillouin zones up to any order in each of which, in principle, the dispersion of collective density fluctuations (phonons in the harmonic approximation) can be measured. For topologically disordered matter like fluids (compressed gases and liquids) and amorphous solids the idea of pseudo-Brillouin zones of lowest order can be introduced in a vague analogy to periodic crystals, and the dispersion of collective density fluctuations can be measured at low momentum transfers  $\hbar Q$ , where the damping  $\Gamma$  of the modes is still acceptably small ( $\Gamma \sim Q^2$  in the hydrodynamic approximation). At low momentum transfers these inelastic peaks can therefore be separated from the dominant quasielastic or elastic line centered at zero energy transfer  $\hbar\omega$ , and the shape of the inelastic lines and their width can be determined precisely, if the resolution of the spectrometer is good enough.  $\Gamma$  and the line shape are the key-information for the understanding of the physical processes which lead to the decay of the collective atomic movements in disordered systems. Via a fit of appropriate models (which fulfil at least the frequency moments up to the second) one can obtain thermodynamic parameters and, in the extension from the hydrodynamic limit of these models, also their dependence on  $Q$  and/or  $\omega$  which are difficult to measure or even inaccessible by other experimental techniques. A further argument for the investigation of the dynamics of disordered matter at low momentum transfers is given by the fact that at  $Q$  well above  $Q_p$  ( $Q_p$  is the  $Q$  value corresponding to the principal peak in the static structure factor  $S(Q)$ ) the dynamics of simple fluids is well described by mean field theories, which give no information about the nature of the interaction potential, and the dynamic structure factor of amorphous solids most often strongly reflects the vibrational density of states (VDOS), which is determined by the single-particle motion.

In spite of all these arguments in favour of the investigation of the atomic dynamics of disordered matter at low  $Q$ -values, experiments of this kind have been carried out only occasionally in the past, because of the extreme difficulties one has to overcome in experiments aiming to cover a sufficiently large energy range at low momentum transfers with good resolution in  $\omega$  and  $Q$  [1].

The combination of energy and momentum conservation in the scattering process from isotropic samples

$$\hbar\omega = E_0 - E \quad (1)$$

$$\hbar^2 Q^2 = [E_0 + (E_0 - \hbar\omega) - 2\sqrt{E_0(E_0 - \hbar\omega)} \cos\theta] 2m \quad (2)$$

with a linear dispersion leads to the condition that the velocity  $v_0$  of the incident neutrons has to exceed the velocity of the excitation  $v_e = \omega\lambda_e/2\pi$  to be measured by about a factor of 1.4 in order to fully cover the dispersion under investigation (sufficient dynamical range). According to equation (2) low  $Q$  values can be obtained at large incident energies only at lowest scattering angles (typically 1-6 degrees) and the large range of e.g. sound velocities requires LAWRIE spectrometers at very different neutron beams ranging from cold and thermal neutrons at reactors to epithermal neutrons at spallation sources.

For cold neutrons most recently a spectrometer has been assembled to meet the extreme requirements of LAWRIE-Experiments and to permit their routine execution. This was achieved by combining the primary spectrometer of a good resolution time-of-flight spectrometer with a well collimated incident beam (here the cold neutron chopper spectrometer IN5) with the secondary spectrometer of a small angle neutron diffractometer, i.e., an evacuated flight path and a (D11 type) x-y detector which after appropriate programming (e.g. rings for isotropic scatterers) collects all scattered intensity without deterioration of the good resolution in  $\omega$  and  $Q$  [2]. As LAWRIE-Experiments become considerably more difficult with increasing incident energy because of dominating multiple scattering and multiphonon processes a first test experiment was carried out with epithermal neutrons on the High-Energy-Transfer (HET) spectrometer at the spallation source ISIS in order to gain experience for the construction of a dedicated LAWRIE spectrometer at a spallation source.

As scattering angles below 1 degree are difficult to access in inelastic neutron scattering (NIS) experiments, the three energy regions of the incident neutrons (cold, thermal and epithermal) lead to rather different ranges of  $Q$  and  $\omega$  values covered in the experiment. With cold neutrons one nearly bridges the gap between NIS and light-scattering experiments for a small region of  $\omega$  values (see Fig. 1), while epithermal neutrons still cover a large part of the first Brillouin zone of crystals with a not too large elementary cell (and of the pseudo-Brillouin zone of disordered materials at  $0 < Q \leq Q_p/2$ ) in a large  $\omega$  range. Thus in the latter case the dispersion of modes with high velocity can be investigated within the first Brillouin zone (Brillouin scattering with neutrons (NBS)).

The LAWRIE option on IN5 was used to investigate in a systematic manner the transition from pure hydrodynamic behaviour as described by linearized hydrodynamic theory or alternatively by the hydrodynamic limits of kinetic or

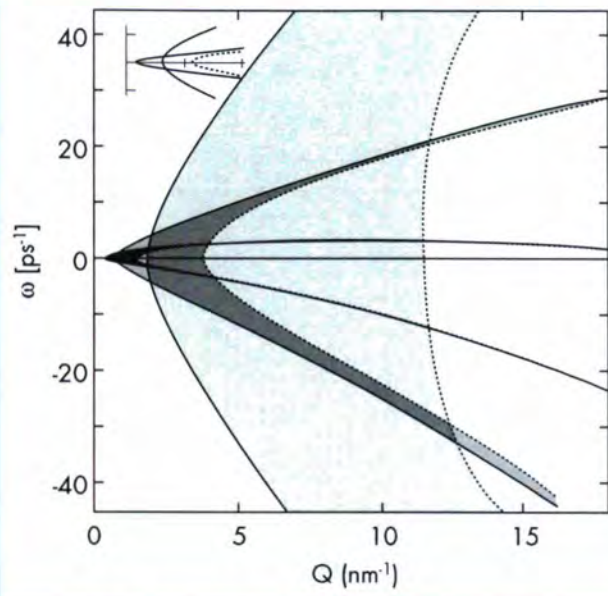

Figure 1 :  $\omega$ - $Q$  space covered in time-of-flight experiments with scattering angles between  $1$  and  $6^\circ$  and three different incident energies :  $2.5$  meV (cold neutrons, black region),  $25$  meV (thermal neutrons, dark grey region), and  $250$  meV (epithermal neutrons, light grey region). In the inset the lowest accessible  $Q$ -region is augmented by a factor of two.

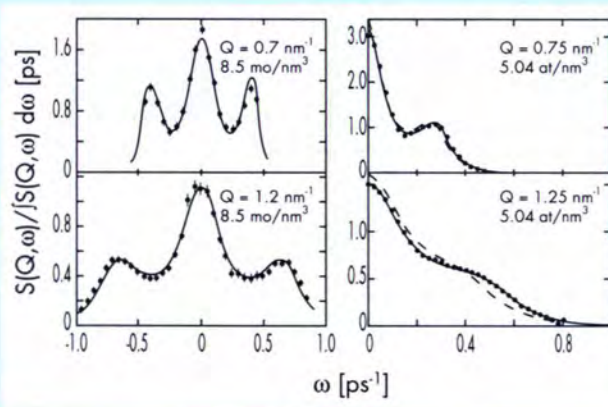

Figure 2 : Two sections at  $Q = 0.7$  and  $1.2$  nm $^{-1}$  through the symmetrized dynamic structure factor  $S(Q, \omega)$  (normalized by the zeroth moment  $S(Q)$ ) for fluid  $N_2$  measured at a density of  $8.5$  mol/nm $^3$  (left-hand side) and at  $Q = 0.75$  and  $1.25$  nm $^{-1}$  for fluid  $^{36}\text{Ar}$  with  $5.04$  atoms/nm $^3$  (r.h.s.) both measured at  $300$  K. The experimental results are compared with the memory-function theory in the hydrodynamic limit ( $S(Q) = S(0)$  in  $\omega_0$  and  $\tau_M = 0$ ) (broken curve for Ar, continuous curve for  $N_2$ ) and with generalized hydrodynamic theory ( $S(Q) \neq S(0)$  in  $\omega_0$  and  $\tau_M \neq 0$ ) (continuous curve for  $^{36}\text{Ar}$ ).

memory function theories [1] to generalized hydrodynamics for compressed  $N_2$  [2] and  $^{36}\text{Ar}$  gases [3] at room temperature. As an example of this type of investigations Fig. 2 shows the observed Rayleigh-Brillouin spectra of fluid  $N_2$  ( $n = 8.5$  mol/nm $^3$ ) and for fluid  $^{36}\text{Ar}$  ( $n = 5.04$  at./nm $^3$ ) which are very well described by hydrodynamic theories (with parameters obtained from macroscopic measurements) at the higher densities and at low  $Q$ -values, and which leave the region of pure hydrodynamics at lower densities and larger momentum transfers, necessitating generalization of hydrodynamic theories. A consistent view of these different results, all measured essentially in the same range of  $Q$  values ( $0.4 < Q < 1.3$  nm $^{-1}$ ), can be obtained if one combines the essential parameters of the system, the occupied volume  $n\sigma^3$  and the Enskog mean free path

$$\ell_E = 1/(\pi\sqrt{2} n\sigma^2g(\sigma)),$$

with that of the experiment, the momentum transfer  $\hbar Q$ . Here  $n$  is the number density,  $\sigma$  the hard-core diameter and  $g(\sigma)$  the radial-distribution function for hard spheres at contact. In this framework (see Fig. 3), because  $n$  enters in ordinate and abscissa, the experiments performed with different fluids follow approximately the diagonal and an approximate common limit for the applicability of hydrodynamic theory to the experimental results obtained for molecular  $N_2$  and atomic  $^{36}\text{Ar}$  was found for  $Q\ell_E$  between  $0.25$  and  $0.3$  [1,3,4]. This limit is about 3 times higher than predicted by revised Enskog theory for hard-sphere fluids. It can be interpreted in such a way that about 20 collisions are needed to restore hydrodynamic conditions during the time needed by the excitation to propagate by one wavelength  $\lambda_e$  [1].

Fig. 3 also shows that fluid  $^{36}\text{Ar}$  has been investigated at 10 times lower density, i.e., in the two-particle collision or Boltzmann limit (free particle limit here reached at low  $Q$  values !). In this case the linear term of the density expansion of the dynamic structure factor  $S(Q, \omega)$  was determined for the first time [5]. Predictions of the revised Enskog theory are in rather rough qualitative agreement with the experimental results only for  $Q < 0.95$  nm $^{-1}$  and in contrast to the theoretical predictions, the linear term of  $S(Q, \omega)$  shows considerable dependence on momentum transfer. Thus it was concluded that this linear term is rather sensitive to the two-particle interaction potential in dilute gases [5].

Finally, Fig. 4 shows the results of a test experiment carried out on HET (ISIS) with an incident energy of  $180$  meV where the dispersion of collective density fluctuations in the metallic glass  $\text{Mg}_{70}\text{Zn}_{30}$  was studied

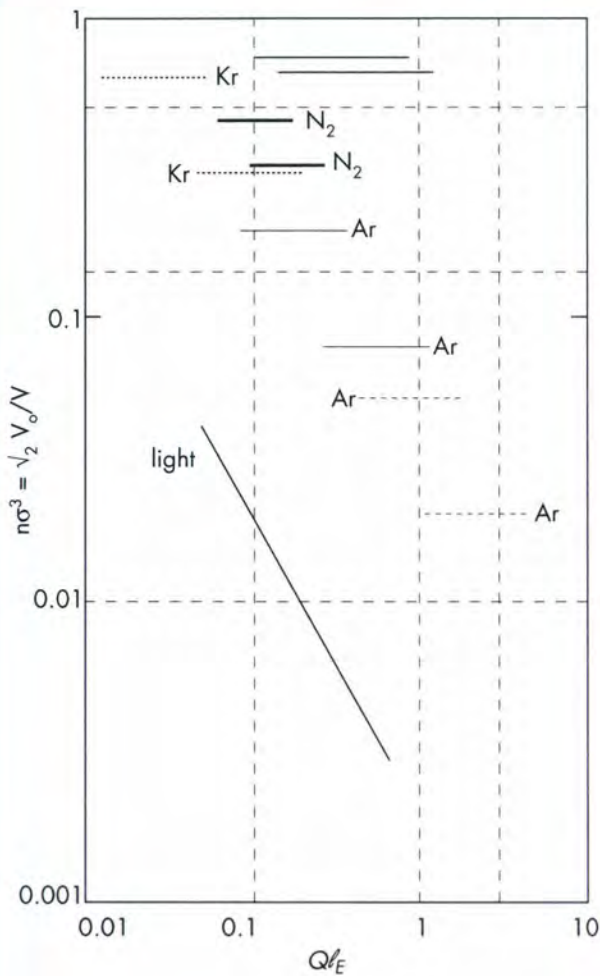

Figure 3: The 'phase diagram' for hard-sphere fluids (upper left corner: hydrodynamic limit, lower right corner: free particle limit) applied to the NBSE done on Ar at 303 K and densities of 5.04, 2 (full lines), 1.43 and 0.49 atoms nm<sup>-3</sup> (broken lines) and on N<sub>2</sub> at densities of 8.5 and 5.9 molecules nm<sup>-3</sup> (bold continuous lines). For both systems a common transition region from the hydrodynamic to the generalized hydrodynamic description of the dynamics of these fluids can be defined for  $Q/E$  between 0.25 and 0.3. For comparison the location of normal NIS experiments on liquid Ar (highest values of  $n\sigma^3$ ), of future investigations of Kr (dotted lines) and of a light scattering experiment are also indicated in the 'phase diagram'.

[6]. With thermal neutrons only the downsloping part of this dispersion just below and around  $Q_p$  can be studied [7]. Now the dispersion was determined across its maximum near  $Q_p/2$  (13 nm<sup>-1</sup>) down to  $Q = 12$  nm<sup>-1</sup>. Good agreement was found with the results of the earlier investigation in the overlapping Q-range and the experimental results now also agree with the results of recent computer simulations of the same glass.

Here only those experiments were discussed which were partly finished before the reactor shutdown. First test experiments had been done on the LAWRIE spectrometer option of IN5 by J. Kjems and D. Richter with the aim of measuring Brillouin scattering in aerogels, by R. McGreevy and collaborators in order to study the critical exponents via the Q-dependence of the critical narrowing reflected in the central line of  $S_{cc}(Q, \omega)$  in molten Li<sub>62</sub>Na<sub>38</sub> near the critical point of demixing, and by C. Pappas and collaborators on the critical exponents near the ferromagnetic to paramagnetic transition in re-entrant Au<sub>1-x</sub>Fe<sub>x</sub>. All these experiments were not completed before the reactor shutdown of the HFR and they will have to be continued after improvements of the LAWRIE spectrometer.

Considering the full range of incident energies, i.e. the LAWRIE option on IN5 (or at NEAT of HMI in future), a similar set up on a thermal beam and a dedicated instrument with lower scattering angles than provided by HET on a spallation source, one could imagine a rather broad application of LAWRIE spectrometers. Besides critical scattering and magnetic scattering mentioned above, the vibrational dynamics in soft materials like polymers, colloids, and emulsions, the faster parts of the relaxational and diffusive motions in colloids and emulsions, which cannot be studied at low momentum transfers on a spin-echo spectrometer or in real time SANS experiments, the dynamics of other macromolecular systems such as biological substances,

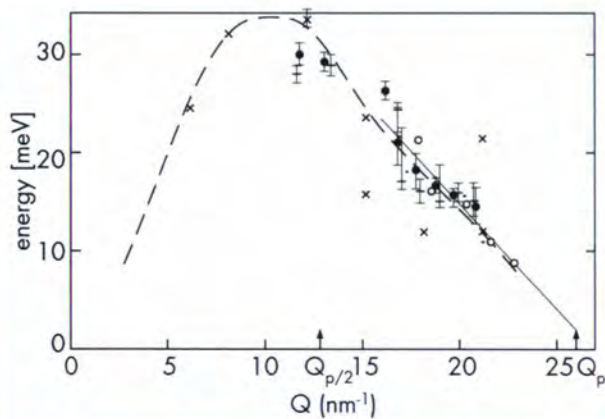

Figure 4: Dispersion of longitudinal modes as obtained from the total dynamic structure factor of the metallic glass Mg<sub>70</sub>Zn<sub>30</sub>. ○: previous results from the thermal neutron time-of-flight spectrometer (IN4) ●, —: results from neutron energy loss and gain spectra measured on HET (ISIS). x: from calculated total dynamic structure factor. The broken line is a guide to the eye through these latter results.

the density of state of all incoherent scatterers with large Debye-Waller factors or considerable anharmonicities are only some examples of future applications.

### **References**

- [1] J.-B. Suck, *J. Phys.: Condensed Matter* **3**, F73 (1991)
- [2] P.A. Egelstaff, G. Kearley, J.-B. Suck, J.P.A. Youden, *Europhysics Letters* **10**, 37 (1989)
- [3] U. Bafile, P. Verkerk, F. Barocchi, L.A. de Graaf, J.-B. Suck, H. Mutka, *Phys. Rev. Lett.* **65**, 2394 (1990)
- [4] J.P.A. Yonden, P.A. Egelstaff, H. Mutka, J.-B. Suck, submitted to *Phys. Rev. A*
- [5] P. Verkerk, U. Pafile, F. Barocchi, L.A. de Graaf, J.-B. Suck, H. Mutka, *Phys. Rev. Lett.* **67**, 1262 (1991)
- [6] J.-B. Suck, P.A. Egelstaff, R.A. Robinson, D.S. Sivia, A.D. Taylor, *J. NonCryst. Solids*, in press.
- [7] J.-B. Suck, H. Rudin, H.-J. Güntherodt, H. Beck, *J. Phys. C: Solid State Phys.* **13**, L 1045 (1980), and *Phys. Rev. Lett.* **50**, 49 (1983)

## Biological Structures and Dynamics

### Members of the College

#### At ILL

F. Baud	M.S. Lehmann
F. Bonneté	P. Lindner
V. Bracchi	N. Louis
P. Chenavas	S.A. Mason
J. Chroboczek	R.P. May
C. Cohen-Addad	E. Pébay-Peyroula
A. De Geyer d'Orth	V. Rodriguez
A.J. Dianoux	F. Samatey
A.M. Di Guilmi	V. Schaffhauser
C. Ebel	P. Terech
M. Ferrand	P.A. Timmins
K. Ibel	L. Vuillard
B. Jacrot	G. Zaccai

#### At EMBL

A. Barge	T. Kamashima
E. Bates	U. Kapp
F. Baudin	W. Kremer
H. Belrhali	J. Langowski
C. Berthet	R. Leberman
V. Biou	D. Madern
F. Borel	N. Nassar
W. Burmeister	S. Price
S. Cusack	R. Ruigrok
M.T. Dauvergne	A. Thompson
E. Di Capua	T. Thüne
M.L. Ferri	C. Wilkinson
M. Fujinaga	J. Willison
M. Härtlein	

#### At ESRF

A. Kvik  
A. Miller

#### At Faculté de Pharmacie

M. Cussac

#### At DIEP

M. Roth

## Introduction

Neutron scattering can yield unique information for our understanding of biological structures and dynamics where it is applicable. More and more sophisticated techniques are being employed to enhance the information content of the scattering data; as for X-ray crystallography, genetic engineering comes into play for obtaining molecules of the required amounts and with selective deuteration. But high-performance computers also add their power to the

interpretation of biologically relevant processes, such as the molecular dynamics of molecules which can be studied by inelastic neutron scattering.

More emphasis will be put on sample preparation and characterization by biochemical and biophysical methods such as FPLC and circular dichroism at the ILL, IBS and EMBL.

The replacement of the collimation system of D11 in spring 1991 reduced the time allocation on this instrument considerably. This had a particular impact on biological applications of neutron scattering, because a major part of them concerns small-angle scattering.

The unexpected reactor shutdown has consequences which are probably even more severe for our college than for others: less flux offered at other neutron centres also implies longer measuring times. In the case of biological samples this may not be an alternative because of their limited stability.

The agreement on collaboration between the European Molecular Biology Laboratory (EMBL), which runs an outstation at the ILL, and the ESRF concluded recently, increases our hope that a solution to the space problem on the second floor of the ILL20 building can be found when the ILL is able to contribute a share for the extension of the building. The collaboration with our colleagues at the EMBL is a continuous source of mutual stimulation.

In the following paragraphs some of the main activities of the ILL scientists, visitors and students of College 8 in 1991 are presented.

## Scientific Trends and Highlights in 1991

### Protein structures

#### Lipovitellin

Lipovitellin is a lipid storage protein found in the oocytes of egg-laying vertebrates. It is in part related to the protein components of the serum lipoproteins apo A and apo B which are found in LDL and VLDL (low and very low density lipoprotein) particles, respectively. Lipovitellin may therefore be able to provide us with clues to the binding of lipid or recognition by, for example, the LDL receptor in these metabolically important systems. The structure of the protein component of lipovitellin has been solved to near atomic resolution by the group of L. Banaszak in Minneapolis using X-ray crystallography, but the stored lipid proved to be invisible to X-rays due to the very low contrast between water and lipid. Neutron scattering on single crystals of the complex, using H<sub>2</sub>O/D<sub>2</sub>O contrast variation has located the lipid in a large cavity within the complex (Minneapolis, ILL). The acyl chains of the lipid appear to be in contact with the walls of the cavity, presumably through hydrophobic interactions, whilst the polar heads interact with the solvent at the entrance to the cavity and perhaps with charged amino acids at the base of the cavity. Work is now continuing on the interpretation of the X-ray structure to elucidate further details of these interactions.

### Hydrophobic protein from soy-bean

During the year, work has continued on the solution of the structure of hydrophobic protein from soy-bean (UJF, CNRS and ILL) using X-ray crystallography. Later it is the plan to follow up this work by neutron diffraction studies to locate the water molecules. The protein is well suited for this kind of work having only 80 residues, and it will be interesting to see how the water molecules can arrange themselves taking into account the hydrophobicity of the protein.

The structure analysis followed the standard pattern, where eventually the electron density map was phased using two main heavy atom derivatives. It was, however, very hard to interpret the map, and it was only when the four sulphur bridges were located using the anomalous scattering from sulphur together with the native data, that the peptide chain was traced. At present the crystallographic R-factor is 18.5 % for data to 1.9 Å resolution.

The structure is rather tightly knotted with about 50 %  $\alpha$ -helices. It has the overall shape of a doughnut, leaving a hole in the middle. Its function is not known, but other proteins of the same size and an identical pattern of sulphur bridges are known to be phospholipid transporters, and if they have a similar form one could then speculate that this hole is important for their function.

Consequently, work has therefore been undertaken on the phospholipid transfer protein from wheat. Crystals were grown in the presence of phospholipid, and this had led to crystals where the asymmetric unit is probably a tetramer. Whether this is related to its function as transfer protein will hopefully be clear when the structure is solved, and could at this stage be accompanied by neutron small-angle scattering studies.

### Extracellular matrix

The extracellular matrix is defined as the environment surrounding cells within tissues. This environment is made of proteins and proteoglycans. The matrix is involved in processes such as embryogenesis, wound healing and cancer. The adhesion of cells to tissues is mediated by matrix glycoproteins. Low-resolution studies as well as crystallization attempts of cell adhesion glycoproteins: fibronectin, osteonectin and thrombospondin are in progress (in collaboration with teams in Grenoble, Lyon, London, Manchester, Edinburgh and Geneva).

### Influence of glycosylation on the structure of glycoproteins

Most extracellular proteins bear carbohydrate side-chains. Recent studies have started to show the role of glycosylation on the protein function but there is at present little data on the influence of glycosylation on the biophysical properties of proteins. Chemical and enzymatic deglycosylation is being developed in our biochemistry lab in order to prepare deglycosylated glycoproteins for physical studies.

### Membranes and membrane components

#### Porin

Porin is a protein which permits the selective passage through the outer bacterial membrane of polar molecules up to a cut-off value of molecular weight of about 600. The X-ray structure of Porin from the bacterium *Rhodobacter capsulatus*, has recently been solved to 1.8 Å resolution by the groups of W. Welte and G. Schultz in Freiburg, revealing a secondary structure composed mainly of  $\beta$ -sheet. The crystals were produced after solubilisation of the protein in detergent which is believed to mimic the membrane lipid in its interaction with hydrophobic parts of the protein. Thus studies of the protein-detergent interaction in the crystals could shed light on the protein-lipid interactions *in vivo*. In the x-ray studies to date, however, no detergent structure has been observed, probably due to disorder. A neutron diffraction study has now been undertaken on the crystals of Porin (Freiburg, ILL) to locate the detergent in these crystals. Data have been collected from crystals soaked in four different H<sub>2</sub>O/D<sub>2</sub>O mixtures and interpretation is currently under way using the protein coordinates from the x-ray structure.

#### Dynamics of Bacteriorhodopsin studied by inelastic neutron scattering and molecular dynamics

The bacterium *Halobacterium halobium* lives in extreme salt concentrations such as the Dead Sea. Its purple colour is due to a chromoprotein, bacteriorhodopsin, which constitutes the so-called purple membrane. Bacteriorhodopsin is a light-driven proton pump. The chromophore retinal, covalently attached to the protein in the all-trans conformation is responsible for the absorption of light, which leads to its isomerisation. Conformational changes of bacteriorhodopsin are involved in the proton transport mechanism and are absolutely necessary for the protein activity. The protein consists of seven helices named A to G interconnected by peptide loops, and arranges itself in the purple membrane to form two-dimensional crystals. Under particular conditions of environment (dehydration and/or low temperature) the lattice of the purple membrane shrinks and a variation in dimension of 2 % is observed.

The experimental *in situ* study of the dynamics of bacteriorhodopsin as a function of hydration and temperature (ILL, CNRS, EMBL), shows a correlation between activity and internal motions of the protein. A minimum space is required for large-amplitude anharmonic motions (see Fig. 1). Hydrated purple membranes exhibit such a behaviour (curve 1). For membranes at low hydration, the motions are harmonic up to room temperature (curve 2). A transition in the dynamics of wet membranes seems to appear between 220 K and 250 K, which could be related to diffusive motions and/or overdamped low-frequency modes in these membranes. An important increase in quasi-elastic scattering and a shift towards low frequency of the main spectral component (group of modes) from 20 cm<sup>-1</sup> to 14 cm<sup>-1</sup> was observed with IN6.

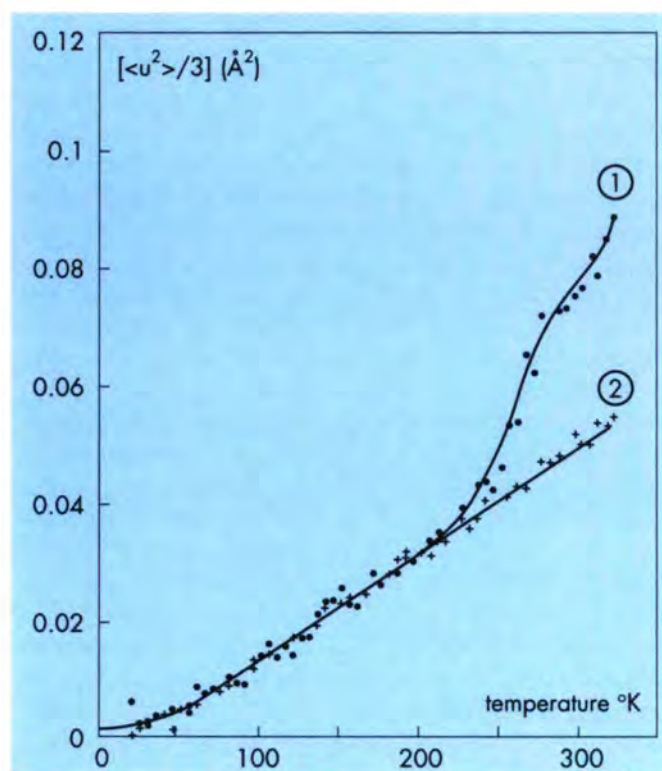

Fig. 1: Mean-square displacement of the hydrogens in purple membrane samples as a function of temperature (IN13 results). 1) wet membranes (hydration 0.55 g  $D_2O$ /g bacteriorhodopsin); 2) dried membranes (0.02 g  $D_2O$ /g bacteriorhodopsin).

The molecular dynamics were simulated at 300 K (ILL, IBPC, Saclay). The protein data-bank structure, which only contains the parts of bacteriorhodopsin known at atomic resolution, was improved by modelling the structure of the loops linking those parts and by a side-chain conformational search. Seven water molecules were added to the protein at sites corresponding to "holes" in the structure. In projection these molecules were located between  $\alpha$ -helices B, C and G, in agreement with neutron diffraction experiments. A 800 K  $\rightarrow$  300 K simulated annealing was performed on the system, followed by a 35 ps period of equilibration and a trajectory calculation of 60 ps. The densities of vibrational states of the whole system and of parts of it ( $\alpha$ -helices) were calculated by the Fourier transform of the velocity auto-correlation function, and compared to the experimental densities (Fig. 2). The simulated densities of states showed more "structure". This can be due to the presence of multiple scattering in the experimental measurements which tends to smooth the spectra. The absence of lipidic environment in the simulation could also lead to a modification of the real mean-force field, where a friction term could be introduced. The simulations must be improved to better describe the experimental results. Nevertheless, it was noted that those helices (B, C, F, G) which are located around the channel of bacteriorhodopsin, where the proton translocation takes

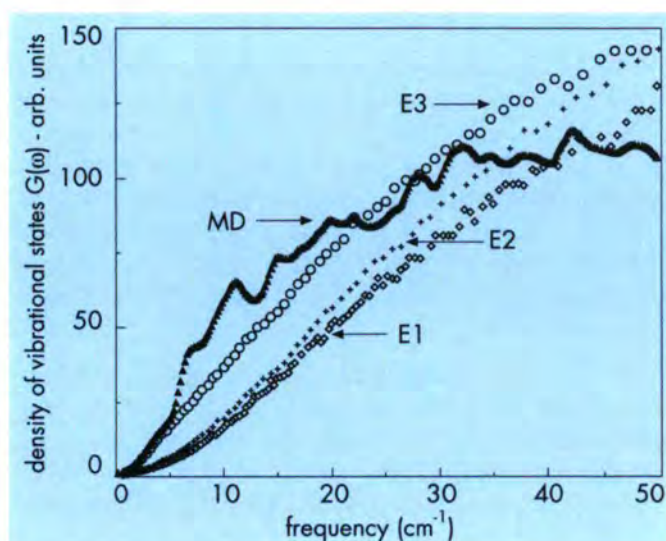

Fig. 2: Comparison of experimental densities of state for different values of the hydration (E1: 0.017 g  $D_2O$ /g bacteriorhodopsin; E2: 0.35 g  $D_2O$ /g BR; E3: 0.55 g  $D_2O$ /g BR) with molecular-dynamics simulations (60 ps trajectory; MD).

place, show more anharmonic motions than the rest of the protein. Neutron diffraction on a trapped state of the photocycle of bacteriorhodopsin exhibited structural changes of these helices. In a first approach, molecular-dynamics simulations seem to be able to sample a large part of the configurational space and to reflect the important conformational changes involved in bacteriorhodopsin activity.

### Protein-nucleic acid interactions and protein synthesis

There are several reasons why neutrons are so useful for the determination of biological structures. First, they permit a distinction to be made between the main components of biological macromolecules, nucleic acids (desoxyribonucleic acid, DNA; ribonucleic acid, RNA), proteins and lipids. Secondly neutrons are sensitive to the deuterium content of these components; this is easily changed by growing microorganisms (bacteria, yeast, etc.) in solutions containing heavy water ( $D_2O$ ). Several biologically relevant molecules consist of two or more chemical classes, like ribosomes, made of proteins and RNA, or viruses, made of proteins and RNA or DNA; others form complexes containing both (like RNA polymerase, together with DNA).

In all living cells, the genetic information is contained in DNA, long chain molecules which usually form quasi-linear double-helical polymers. Before the information contained in the DNA base-sequence can be finally translated by the ribosomes into the thousands of different proteins and peptides present in a cell, base-complementary blue prints in the form of chains of messenger RNA (mRNA) are produced. This duplication process is catalyzed by the enzyme RNA polymerase, which has been studied for many years with SANS.

The mRNA molecules are transferred to the ribosomes, which, by interpreting their base sequences, synthesize new proteins. Ribosomes are particles made up of two subunits of unequal size, each consisting of nucleic acid (2/3 of the mass) and a multitude of different proteins. The large ribosomal subunit (50S) from the intestinal bacterium *Escherichia coli* often used as a "guinea pig" by biochemists consists of a short RNA chain (5S rRNA) and a very long one (23S rRNA), and more than 30 proteins (called L1 to L34, L8 being a complex of proteins, and L7 nearly identical to L12).

#### Protein positions within the 50S ribosomal subunit

A long-term project conducted by scientists at the Max-Planck-Institut für Molekulare Genetik, Berlin, and the ILL aims at establishing a three-dimensional map of the components of the ribosomal 50S subunit in order to contribute to a better understanding of the structure/function relationship. Some of the proteins in the small (30S) subunit (S1 to S21) have been included in the investigation.

The method used consists in incorporating selected pairs of protonated single proteins into "glassy ribosomes", ribosomal particles reconstituted from isolated partially deuterated ribosomal proteins and RNA which are both rendered quasi-invisible for neutrons by a buffer solution with high D<sub>2</sub>O content. The small-angle neutron scattering curves from these particles can be interpreted in terms of the distances between the proteins. The aim of the study is to produce a map of the three-dimensional arrangement of the majority of the 50S proteins on the basis of the table of protein distances. This model is to serve as a scaffold for locating the sites which are important for the function of the ribosome. The reactor shut-down has stopped further data collection, but a publication presenting 50 measured distance values and a model containing the positions of 7 proteins has been published at the end of the year.

#### Low-resolution crystallography of ribosomes

For several years, crystallisation studies have also been made on different ribosomal particles. The most suitable for neutron diffraction up to now was the 50S subunit from *Halobacterium marismortui*. The first goal of the low-resolution neutron diffraction experiments is to distinguish between the protein and the RNA domains. This is achieved by exchanging the solvent with partially deuterated liquid for varying the contrast of the different domains.

Diffraction experiments are carried out on ribosomes at the ILL (DB21) since 1986. Because of the small size and the variable quality of the crystals these experiments are very time-consuming and difficult. There is now an almost complete data set in 100 % D<sub>2</sub>O to 30 Å resolution and an incomplete set in 0 % D<sub>2</sub>O. A tremendous effort was made to obtain larger crystals of ribosomal particles more suitable for neutron diffraction. Larger crystals are obtained from the 50S particle from *Thermus thermophilus*. Before the reactor

shutdown, there was just time to collect a few diffraction data showing that these crystals diffract more than those from *Halobacterium marismortui*. Unfortunately, the data from this test experiment are not sufficient for further calculations.

*Ab initio* phasing methods for low-resolution data were developed. Additionally to direct methods, maximum entropy and likelihood methods developed by Bricogne and Gilmore are used. The phasing of the 100 % D<sub>2</sub>O data is in progress with direct methods. The density maps obtained are consistent with the electron-microscopical model as far as the contours of the ribosome are concerned. The preliminary results from the second phasing method go in the same direction. At present, a two-level model corresponding to proteins and RNA is being developed (in 100 % D<sub>2</sub>O, the protein scattering density is about twice that of RNA). The current results seem very exciting, but at this stage, the validity of this map needs to be confirmed by using the 0 % D<sub>2</sub>O data (MPI Berlin and Hamburg, Rehovot, UJF, DIEP, ILL).

In parallel, Ada Yonath and her coworkers are performing X-ray diffraction experiments. They showed that low-resolution data (at least 150 Å) are very important to define the position of the particle in a density map. They improved the low-resolution data collection, and very recently the low-resolution X-ray data from the 50S of *Thermus thermophilus* were phased using direct methods with an encouraging result. More efforts will be put now in improving the X-ray diffraction data collection from the 50S of *Halobacterium marismortui* in order to compare X-ray and neutron diffraction maps.

#### Viruses and viral components

##### HIV-1 Reverse Transcriptase

The Human Immunodeficiency Virus 1 (HIV-1) is of the retrovirus type, which means that its genetic information is stored as viral ribonucleic acid (RNA) rather than DNA. Therefore, it carries an enzyme of its own called reverse transcriptase which is able to transcribe the genetic code into DNA, which then can be incorporated into the host genome to be switched on by external events. Reverse transcriptase is one of the major targets in drug design against AIDS. Only a small substructure of the enzyme was elucidated by X-ray crystallography, namely the "p15" domain responsible for digesting the original viral RNA strand in the course of the synthesis of the complementary DNA (plus) strand. p15 stands for a protein of 15 kDalton. The whole RT molecule is a "hetero-dimer" consisting of two subunits, a p66 subunit and a p51 subunit, the sequence of which is identical to that of p66, with the exception of the p15 domain, cleaved off the C-terminal by a special enzyme.

By comparing the neutron scattering curves from a p66-p66 "homo-dimer" and from a genetically engineered heterodimer consisting of a natural p66 subunit and a deuterated p51 subunit, in buffer solutions containing

different mixtures of H<sub>2</sub>O and D<sub>2</sub>O, the first structural information on HIV-1 reverse transcriptase in solution, based on experimental data, was obtained. Together with biochemical information, a model of reverse transcriptase can be presented which is shown in Figure 3 see page 88 (MPI Martinsried, Basel, Argonne, Lyon, Cleveland, ILL).

### Adenovirus fibre

The adenoviruses constitute a family of non-enveloped viruses with icosahedral symmetry. The penetration of the virus into the cell is mediated by an interaction between one of the virus' structural proteins, called fibre, and the cell receptor. The fibre is an elongated trimeric protein protruding from the surface of the virion; it is organized in the form of a shaft with a C-terminal knob, interacting with cellular receptors. (Protein sequences start with an N-terminal amino-acid and end with a C-terminus).

The trimerization of the fibre protein of adenovirus serotype 2 was investigated. For this purpose, the N- and C-terminal portions of the fibre, comprising about 40 % and 30 % of the length of the fibre, respectively, were expressed, i.e. produced by genetic engineering methods, in *Escherichia coli*. The conformations of these "recombinant" proteins were analysed by chemical cross-linking.

The N- and the C-terminal fragments were treated separately with different cross-linking agents which make artificial, stable contacts between neighbouring protein chains. Denaturing polyacrylamide gel electrophoresis allows one to distinguish between isolated protein chains and cross-linked ones by assessing their relative molecular masses in the presence of molecular-mass markers on the same gel. The N-terminal fragment behaved under these conditions as a dimer, whereas the C-terminal fragment had the mobility of a trimer. These experiments show that to trimerize the fibre needs its C-terminal part. At present, the chimeric fibre where the C-terminal part is attached to the N-terminal fibre portion is being constructed, in order to see whether the C-terminal part can confer the ability to trimerize to the fragment which is unable to trimerize by itself (IBS, ILL).

### Effects of hydrostatic pressure on Turnip Yellow Mosaic Virus

Small-angle neutron scattering was used to investigate (Osnabrück, Strasbourg, ILL) the thermal stability of Turnip Yellow Mosaic Virus under hydrostatic pressure, which is a unique tool for obtaining thermodynamic information about chemical equilibria. SANS is an ideal method for such studies, because it allows one to distinguish the virus capsid from the core by contrast variation, and because the thick windows needed for high pressure studies represent no major obstacle for neutrons.

Turnip Yellow Mosaic Virus is a prototype of a simple isometric plant virus consisting of a nucleic acid protected

by a closed protein shell of icosahedral symmetry, stabilized by strong protein-protein interactions. It was found that hydrostatic pressure enhances the stability of Turnip Yellow Mosaic Virus, whilst it was known that it decreases with increasing pH and increasing temperature. This behaviour is different from another small isometric virus, Bromegrass Mosaic Virus, which is stabilized mainly by RNA-protein interactions. It is interesting to note that pressure is known to promote the denaturation of proteins and the dissociation of many biologically important protein-protein aggregates.

### Quasi-Laue diffraction

The collaboration between the EMBL and the ILL on the development plans for a quasi-Laue diffractometer for measurements on crystals with very large unit cells has continued during the year. A prototype detector using neutron to light conversion combined with a position sensitive photomultiplier was completed, but unfortunately too late to be tested at the ILL. A short test was therefore conducted (in collaboration with LAPP, Annecy) at the neighbouring reactor Siloé of the CEA. This showed the resolution to be better than 1 mm. It is the hope over the next years to try to test this detector at other neutron sources. It should be noted that beyond its use in the proposed instrument this detector will have a large range of other functions in crystallography, and the project should therefore be pursued vigorously.

In order to have real data for continuing the development of data-reduction methods, measurements on a crystal of triclinic lysozyme were carried out at the spallation source ISIS, the idea being that these data, summed over the time dimension, would resemble data from the proposed machine. A standard crystal from the ILL was used, but although this measurement allowed for an estimate of the ratio between data-collection rates on ISIS and on instruments presently available at the ILL, the intensities were too weak to be useful.

The possibility of employing an image plate, which is presently becoming a standard tool in X-ray protein crystallography, is also being considered. The neutron to X-ray conversion is carried out with a thin Gadolinium foil, which produces gamma-rays in the convenient range. A first, limited test was implemented at the Orphée reactor, and gave promising results. A major concern is the  $\gamma$ -sensitivity of this detector, but very likely the energy of most of the radiation is too high to be detected.

Secretary: R. May

## Molecular Spectroscopy, Surfaces and Mesophases

### Members of the College

K. Al Usta	H.J. Lauter
L. Andersen	K. Liss
I. Anderson	A. Magerl
R. Bateson	J. Pannetier
H. Blank	W. Petry
S. Bramwell	F. Rieutord
A.J. Dianoux	C. Ritter
J. Eastoe	P. Terech
B. Farago	J. Williams
A. Heidemann	J. Wuttke
G. Kearley	

### Introduction

By this point in the Annual Report it will not be necessary to remind the reader that the shut-down of the reactor of the Institut Laue-Langevin for three quarters of 1991 has greatly disrupted the experimental life of all of the Colleges. College 9a members have had to seek neutron beam time at different institutes or undertake other, non-neutron, experimental and or theoretical projects. However, the increased availability of time for data refinement and analysis has allowed College members to complete projects which may have been dormant for some time.

### Scientific Highlights in 1991

#### Low-temperature tunnelling transitions

There continues to be considerable interest in College 9A in the spectroscopy of symmetric-top and spherical-top rotors in ionic solids. Of note this year has been the study of the fine structure arising in tunnelling transitions from the coupling of two NH<sub>3</sub> rotors. Co(NH<sub>3</sub>)<sub>6</sub>(PF<sub>6</sub>)<sub>2</sub> provides the only example of a near free-rotor in a crystalline solid. On the basis of the observed peak position and its temperature dependence, a weak six-fold barrier to rotation of 15.0 meV has been determined. More recently, high resolution measurements have given additional inelastic structure where the temperature dependence of the line positions and intensities reveals the nature of the transition, that is, whether it is a transition between two excited states or between the ground state and an excited state. These high resolution measurements were carried out on IN5 and on the IRIS spectrometer in the RAL, United Kingdom. Four lines were observed at energy transfers of  $\leq 0.542$  meV. To fully analyse this data it is necessary to assume some form for the potential within which the transitions are occurring. This is normally determined by the geometry of the rotor, for example, for the NH<sub>3</sub> rotor a three-fold potential would be the natural choice. However, it was thought that the fine

structure in the spectrum arose from the coupling of two such NH<sub>3</sub> rotors and so a potential of six-fold symmetry would also be reasonable. To distinguish between these two possible potentials one must calculate, for both models, the spectrum at higher energy transfer and then measure it (there are an additional 4 lines between 1.0 and 2.4 meV) and finally compare the experimentally derived spectrum with the calculated spectra. Figure 1 displays the low-energy inelastic neutron scattered spectrum of Co(NH<sub>3</sub>)<sub>6</sub>(PF<sub>6</sub>)<sub>2</sub> at a variety of sample temperatures as measured on IN5.

On this basis it was found that the six-fold coupled potential is a better overall representation of the system but that it was difficult to ignore the ability of the three-fold barrier to well reproduce the lower energy transitions. It was concluded that coupling of NH<sub>3</sub> rotors could explain the observed spectrum, however, that it was inter- and not intra-molecular coupling which was the more important, that is, the two rotors which are coupled are on different Co(NH<sub>3</sub>)<sub>6</sub><sup>2+</sup> ions and that the close proximity of the NH<sub>3</sub> groups on the same ion seems to play very little part in the rotational dynamics. The presence of a six-fold term between staggered coaxial NH<sub>3</sub> groups, on neighbouring ions, is readily visualised, and it is conceivable that weaker intramolecular interactions may give rise to a three-fold term which is important close to the rotational ground state.

Another interesting tunnelling problem which has been investigated occurs in the Nickel hexamine salts, Ni(NH<sub>3</sub>)<sub>6</sub>(I<sub>2-2x</sub>Br<sub>2x</sub>). Here the impetus was to correlate the observed tunnelling frequency with the nature and properties of the anion. It was of interest to elucidate whether or not the anions play a direct role in determining the rotational barrier or if the barrier changes are due to changes in the lattice

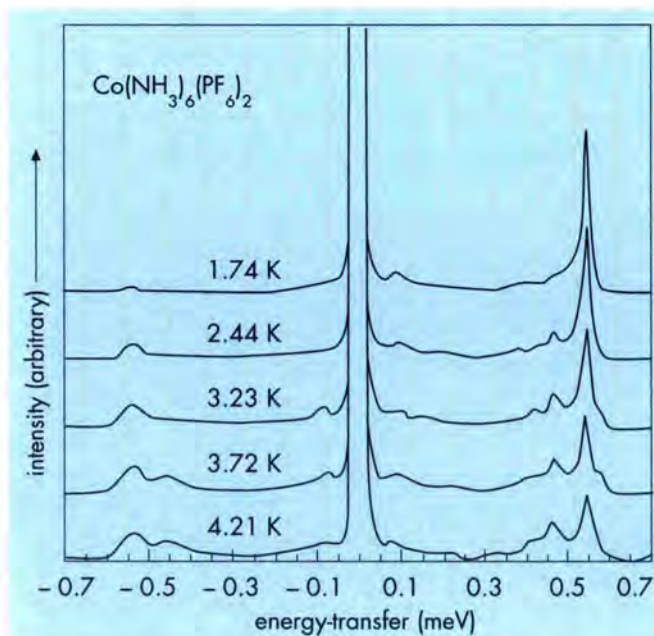

Fig. 1: The low-energy INS spectrum of Co(NH<sub>3</sub>)<sub>6</sub>(PF<sub>6</sub>)<sub>2</sub> at various sample temperatures measured on IN5.

parameter. To this end  $\text{Ni}(\text{NH}_3)_6\text{I}_2$  with varying amounts of iodide exchanged for bromide, within which the distribution of next neighbours could be modelled, was synthesized and the inelastic scattering measured on IN5. It was found that the trend in moving from the pure iodide salt to the pure bromide salt is a progressive increase in barrier height, see Fig. 2.

From a powder X-ray study of the various mixed salts the lattice parameter of the pure hexamine bromide was found to be 4% smaller than that of the pure hexamine iodide. Only a 0.7% decrease was found on going from pure iodide to 50 atom percent bromide. The near linearity of the change in lattice parameter over the same concentration range implies that the anions play a strong part in the determination of the rotational barrier of the  $\text{NH}_3$  groups. Suggestive of short range interactions as the inter-ionic spacings are not changing by very much.

### Magnetic excitations

Chemists and physicists have shown great interest in exchange-coupled clusters of magnetic ions. These systems serve as simple models for the investigation of exchange interactions. Inorganic chemists in particular continue to benefit from inelastic neutron scattering experiments to understand the complex magneto-chemistry of transition metal compounds. Of particular note this year was the investigation of the  $\text{Ti}^{2+}(\text{Mn}^{2+})_6$  spin cluster in  $\text{Ti}^{2+}$  doped  $\text{MnBr}_2$  and  $\text{MnCl}_2$  with inelastic neutron scattering on IN5. The doped material had been extensively studied with optical spectroscopic techniques and a complex multiplet structure was observed arising from the strong hyperfine interactions present in the solid. The inelastic neutron study was able to probe these spin multiplet levels directly and has yielded exchange splitting for both the electronic ground state and the singly excited  $4E_g, 4A_{1g}$  state.

It was found that the  $\text{Mn}^{2+}\text{-Mn}^{2+}$  exchange could be neglected in comparison with the  $\text{Mn}^{2+}\text{-Ti}^{2+}$  exchange interaction and that in the lowest levels of the ground state the ordering has a ferromagnetic appearance, despite the antiferromagnetic nature of the  $\text{Mn}^{2+}\text{-Ti}^{2+}$  exchange. In addition it was shown that the large spins,  $S=16$ , of the six nearest neighbour  $\text{Mn}^{2+}$  ions are lined up parallel by the dominant coupling to the much smaller  $\text{Ti}^{2+}$  spin.

### Fixed window scans

One of the projects nearing completion in College 9a has used IN13 to study low frequency motions of simple aromatic molecules in their respective solids as a function of sample temperature, that is, the measurement and interpretation of  $S(Q, \omega \approx 0)$ . When the analysing part of a backscattering spectrometer such as IN13 is set to the same energy as the incident neutron beam an energy window is defined, the instrument resolution function ( $\sim 8 \mu\text{eV} \approx 2000 \text{ MHz}$ ), which may serve as a means of monitoring line width changes during scattering.

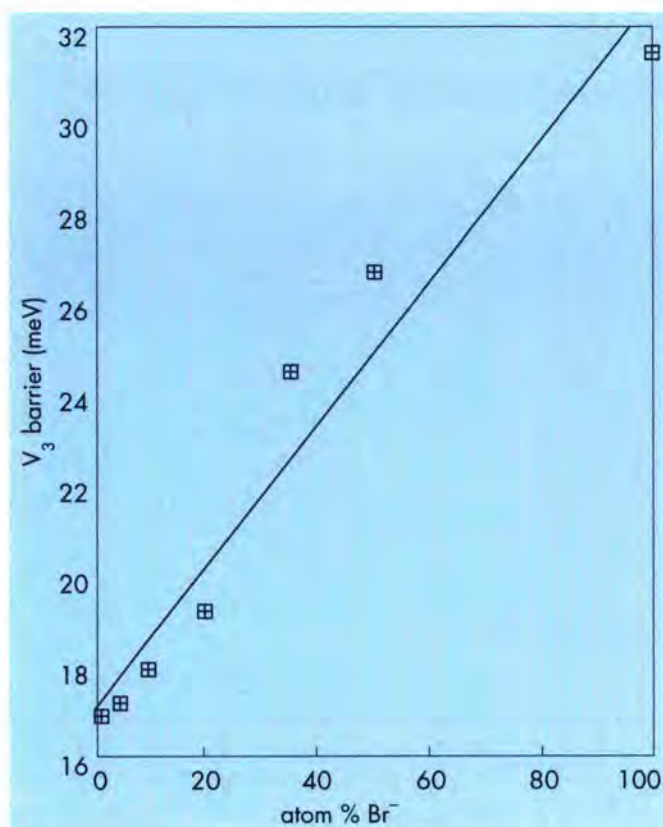

Fig. 2: Variation of the threefold potential,  $V_3$ , with atom %  $\text{Br}^-$  in  $\text{Ni}(\text{NH}_3)_6(\text{I}_{2-2x}\text{Br}_{2x})$

In such a “fixed window experiment” one determines the spectral intensity at  $\hbar\omega \approx 0$ . At low temperature the purely elastically scattered line and any quasi-elastic spectrum are contained within the energy window. The phonon spectrum will be at a much higher frequency, of order a few meV, and because of the high energy resolution of the spectrometer will not contribute to our measurements. Then as the temperature increases the measured elastic line intensity falls, see Fig. 3, due to the Debye-Waller factor. Here the molecules are fixed in the solid and are undergoing small amplitude oscillations whose magnitude may be determined by plotting

$$\text{In } S(Q, \omega \approx 0) \text{ versus } Q^2.$$

As the temperature increases the quasi-elastic spectrum will broaden and will fall outside the energy window of the spectrometer. In the case of benzene, Fig. 3, this is clearly seen to commence at  $T \sim 150 \text{ K}$ . As the quasi-elastic spectrum broadens with increasing temperature the observed scattered intensity continues to fall. Thus giving the observed step in the temperature dependence of the  $\text{In } S(Q, \omega \approx 0)$  curve. In this temperature region the characteristic frequency,  $\nu_c$ , of any motion (the origin of the quasi-elastic scattering for benzene is a rotation about the  $\text{C}_6$  axis) is of order  $\hbar/\Delta E$ . Where  $\Delta E$  is the width of the energy window. In the case of benzene it is seen that the quasi-elastic line width continues to increase with increasing

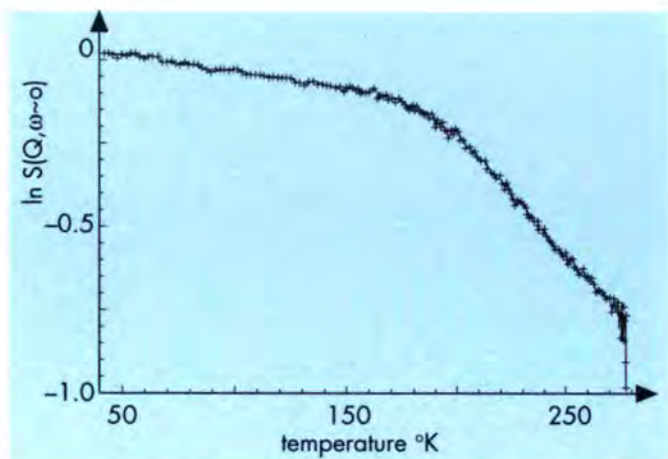

Fig. 3: Fixed window scan for polycrystalline benzene, below 150 K there is only the Debye-Waller attenuation of intensity, however, above 150 K molecular rotation commences. The material melts at the highest temperatures shown. The measurement was made at  $Q = 1.19 \text{ \AA}^{-1}$ .

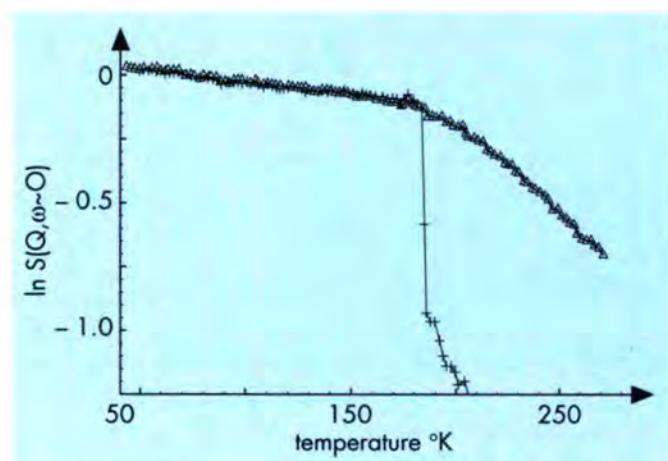

Fig. 4: Fixed window scans for toluene (+) and benzene ( $\Delta$ ), see text for details. The measurements were made at  $Q = 1.19 \text{ \AA}^{-1}$ .

temperature and so the measured intensity continues to fall right up to the melting point at 278 K. In Fig. 4, a similar fixed window scan for toluene is displayed and it is clearly seen that the molecular dynamics are very different from that of benzene. At the temperature where benzene starts to undergo rotational reorientation, the toluene melts. Because of its less symmetric shape the toluene molecule does not have available a rotational degree of freedom in the solid and must seek other routes for minimising molecular interactions.

To understand these observations we make use of an analogy with NMR spectroscopy. In solid state NMR the narrowing of an observed resonance line with temperature is analysed in terms of the Debye correlation time,  $\tau_c$ . If we write  $\tau_c \sim 1/\nu_c$ , which is the average rate of oscillation of

the molecule containing the resonating or scattering atom, we may write after the theory developed by Bloembergen, Purcell and Pound.

$$(\Delta\nu)^2 = (\Delta\nu_0)^2 \frac{2}{\pi} \tan^{-1}(\alpha\Delta\nu/\nu_c) \quad (1)$$

Where the line width (a frequency) is  $\Delta\nu$ ,  $\Delta\nu_0$  is the second moment of the rigid lattice which contains the scattering/resonating atom, it represents the un narrowed line width. The constant,  $\alpha$ , is of order unity.

If we think of the rigid lattice line width as our energy window,  $\Delta E$ , we may consider Eq. 1 as representing the loss of scattered intensity as the quasi-elastic component of the scattering continues to broaden due to the thermally activated reorientational motion defined by  $\nu_c$ . In this thermally activated motion we assume that the rate of molecular transitions from one equivalent site to another, characterised by the correlation frequency,  $\nu_c$ , is low and the lattice is still practically rigid. It may then be assumed that  $\nu_c$  is of the Arrhenius form

$$\nu_c = \nu_0 \exp(-E_a/RT) \quad (2)$$

Where  $E_a$  is an activation energy corresponding to the height of the potential barrier between two equivalent molecular positions. In our near-elastic scattering experiment we may interpret our measurement as

$$S(\hat{Q}, \omega = 0) = \exp(-2W) \left\{ F(\hat{Q}, 0) + \left( 1 - F(\hat{Q}, 0) \frac{2}{\pi} \tan^{-1} \left( \frac{\Delta E}{\nu_c} \right) \right) \right\} \otimes R \quad (3)$$

Where  $F(Q, 0)$  is the scattering law at  $\omega = 0$  (the elastic line) and  $\{1 - F(Q, 0)\}$  is that part of the elastic line scattered out of the energy window. Both terms being subject to a Debye-Waller attenuation. The observed scattering law is convoluted with the instrument resolution function,  $R(\omega)$ . One thus has a direct means of deriving the Debye-Waller factor at low temperatures and the Arrhenius parameters which characterize molecular rotational motion provided one has a model for the molecular reorientation.

### Partially Oriented Samples

A great many of the samples studied with quasi-elastic and inelastic neutron scattering are powders, that is, randomly oriented collections of microscopic crystals, large single crystals may be difficult or impossible to obtain and one has to work with averaged crystal orientations and hence an average over scattering vector.

However, much more information can be obtained from such scattering experiments if the orientation of the molecules, scatterers, in the solid sample is known. This has been demonstrated by some recent experiments.

Polyacetylene  $(\text{CH})_x$  is the prototype of a large class of conjugated polymers, it may be doped or intercalated with alkali metal atoms and metallic levels of conductivity

achieved. The concentration of the dopant had been shown to play an important role in determining the structure of the intercalate. However, to understand in detail the intercalation process requires information about the relative strengths, of inter-chain and intra-chain interactions, that is, about the dynamics of the phonon spectrum. Recent experiments on IN6 have demonstrated the feasibility of using incoherent inelastic neutron scattering from oriented polymer films to obtain both polarization and energy information about the lattice modes of these crystalline polymers. The polymer film was stretch oriented and individual films, of order 10  $\mu\text{m}$  thickness, were assembled in a sample container. The  $c$ -axis mosaic full width at half maximum was about  $30^\circ$  with  $\hat{a}$  and  $\hat{b}$  randomly oriented in the plane perpendicular to  $\hat{c}$ . This relatively large mosaic spread of chain axes did not prohibit the subsequent analysis. Figure 5a shows the experimental geometries and Fig. 5b shows the measured density of states for cis-rich  $(\text{CH})_x$  at  $T = 295$  K. The full analysis of the data has given considerable insight into the 3 D dynamics of  $(\text{CH})_x$ . For example, a line at 2.9 meV was shown by its polarization dependence, the preferential orientation of  $Q$  with respect to the chain axis, to be a damped translational mode along the chain direction.

Similar inelastic neutron experiments have recently been performed on  $n$ -alkanes intercalated in urea clathrates in order to observe the molecular motions of the hydrocarbon molecules, see the specialist report at the end of this section. The success of this experiment on polyacetylene has led to subsequent work on oriented films of polyaniline.

In a similar vein is the coherent quasi-elastic investigation of perfluoro- $N$ -Eicosane,  $\text{C}_{20}\text{F}_{42}$ , undertaken on IN13, IN8 and D10. This material occurs in well-ordered layers of hexagonal symmetry. The layers are stacked on top of one another to produce a lattice of rhombohedral

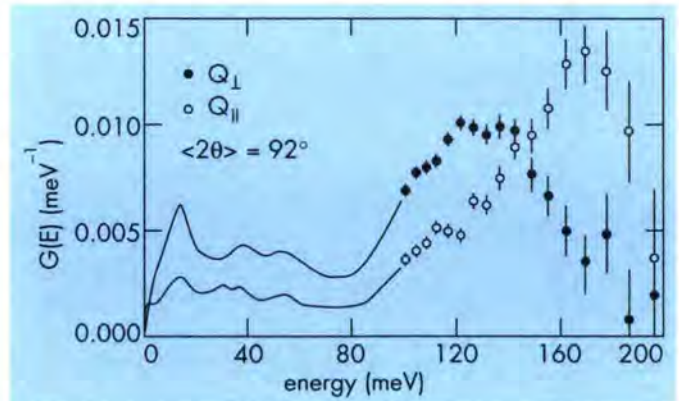

Fig. 5b: cis-rich  $(\text{CH})_x$  density of states  $g(E)$  at 295 K, summed over a range of scattering angles centered at  $\langle 2\theta \rangle = 92^\circ$  and normalized over the range 0-200 meV. Open circles:  $Q_{\parallel}$  (see Fig. 5a). Solid circles:  $Q_{\perp}$  (see Fig. 5a). Data points have been omitted for clarity below 100 meV.

symmetry at room temperature. There is a first order phase transition at 200 K which produces, on cooling, a crystal of monoclinic symmetry with the loss of molecular mobility. Of interest in the recent experiments was the longitudinal and rotational motion of the molecules in the high temperature phase. Diffuse neutron and X-ray scattering had shown that there was some disorder in the molecular layers arising from correlations between the large amplitude motions of the anisotropic molecules about the solid  $c$ -axis.

Quasi-elastic and inelastic spectra were recorded to obtain  $S(Q, \omega)$  and thus investigate the dynamics in particular regimes of correlation times,  $10^{-9} \leq \tau \leq 10^{-12}$  s. Because the atoms present in the sample are all coherent scatterers the observed scattering is a sensitive probe of correlated molecular motions.

As a consequence of the high degree of molecular order within the sample, a collection of platelets each having the  $\hat{c}$  axis perpendicular to its surface, the experiments were able to describe in detail the translational diffusion and rotational motion of the  $\text{C}_{20}\text{F}_{42}$  molecules near the phase transition at 200 K. The origin of these dynamics was probed by a study of phonon dispersion which yielded the relative magnitude of the nearest neighbour interaction, between molecules in the same layer and in adjacent layers.

### Benzene-Hexafluorobenzene

There continues to be considerable interest in the structure and dynamics of the solid formed by mixing benzene and hexafluorobenzene. In the last twelve months experimental work on this system has included an IN6 study of molecular diffusion in the highest temperature phases together with an extensive investigation with diffraction techniques.

The solid state phases of  $\text{C}_6\text{D}_6:\text{C}_6\text{F}_6$  were first characterised by thermodiffractionometry on the high-flux diffractometer D1B. All four phases which exist below the melting point (298 K) were clearly identified. Subsequently,

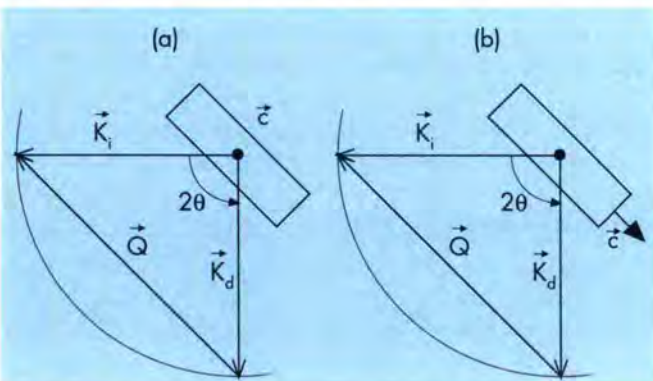

Fig. 5a: Experimental geometries (incident wave vector  $K_i$ , scattered wave vector  $K_d$ , wave-vector transfer  $Q$ , scattering angle  $2\theta$ ):

(a)  $Q_{\perp}$  configuration; the average  $c$  axis is normal to the figure, thus  $Q$  is perpendicular to the chain axis.

(b)  $Q_{\parallel}$  configuration;  $Q$  is quasinormal to the chains for small scattering angles but parallel to the chains for large scattering angles. An elastic event is shown; the above condition is also satisfied for inelastic scattering by summing over a range of  $2\theta$  matched to the  $c$  axis mosaic.

experiments at longer neutron wavelengths were undertaken on D1A to determine unit cells for each of the four phases. This work showed that phase I is rhombohedral in agreement with previous work and that the lower temperature phases have low symmetry. Attempts at auto-indexing were only partially successful with a monoclinic cell being found for phase IV. However, due to the similarity in the neutron scattering cross sections for C, F and D this cell was suspected to be only a subcell.

High-resolution X-ray data on phases II, III and IV were obtained on the Diffractometer 2.3 at the SERC Synchrotron Radiation Source at Daresbury, UK, using a helium cryostat and flat-plate sample geometry. Phases II, III and IV were immediately auto-indexed as monoclinic, triclinic and monoclinic with probable space groups  $I2/m$ ,  $P1$  and  $P2_1/a$ , respectively. For the lowest temperature phase, IV, direct methods were used to locate the positions of the 9 crystallographically-independent C and F atoms in the structure. Accurate atomic positions including deuterium were then obtained by Rietveld refinement of the powder neutron data collected on D1A leading to the structure illustrated on the front cover of this Annual Report.

This work represents a significant step forward as previous structure determinations by direct methods from powders have typically involved systems with a small number of atoms with at least one atom being either a 2nd row element or a transition metal. Here for the first time, a structure has been solved and refined containing 1st row elements only by a combination of neutron and synchrotron radiation powder methods.

In order to solve the higher temperature phases, a novel procedure was used taking advantage of the nearly identical neutron scattering cross sections of  $C_6F_6$  and  $C_6D_6$ . In the powder pattern, the triclinic cell of phase III containing two pairs of  $C_6D_6:C_6F_6$  molecules arranged in columns appears to be a-centered and half the size along the c-direction. This allows initial refinements to be based on a structure containing a single "average" hexagonal  $C_6X_6$  molecule allowing the determination of the orientation of the plane of the rings. Subsequently, the synchrotron radiation data were used to distinguish between  $C_6F_6$  and  $C_6D_6$  molecules, a novel twist in the determination of structures of powders.

### Grazing angle magnetic neutron diffraction on $MnF_2$

Surface scattering continues to be of interest to College 9a, of note this year is a study of  $MnF_2$ . X-Ray and neutron scattering become surface sensitive when the grazing angle diffraction technique (GID) is applied. This technique can provide detailed structural information of interfaces and thin films and is particularly interesting for investigations of near surface magnetic ordering with neutrons. Previous neutron GID measurements have been performed only on nuclear structures (see Ann. Rep. 1990), recently X-ray and neutron experiments were combined to study the structural and magnetic ordering near the (100) surface of a  $MnF_2$  single crystal (LMU München, CNRS Grenoble).  $MnF_2$  is a model system of an uniaxial Heisenberg Antiferromagnet and of particular interest for measurements of the near surface

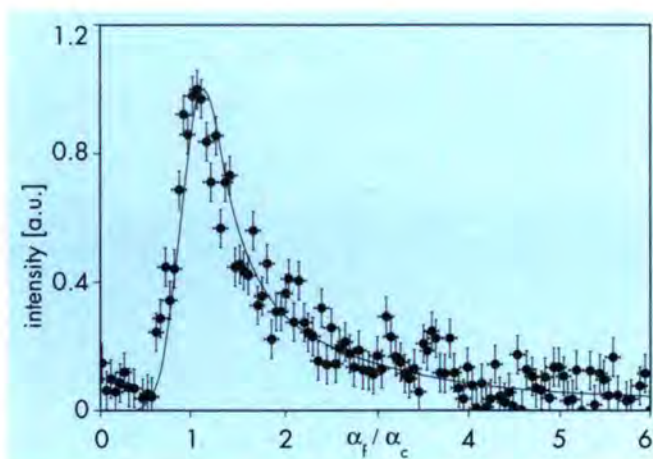

Fig. 6:  $a_f$ -profile of the (100) Bragg reflection from a (001)  $MnF_2$  surface observed under grazing incidence angle of  $a_i/a_c=0.8$  after cooling the sample below the Néel temperature.

critical scattering since theories of phase transitions in semi-infinite systems predict large differences when compared to the bulk behavior. The magnetic depth profile of the  $Mn^{2+}$  lattice was investigated by neutron diffraction on the pure antiferromagnetic (100) reflection. Fig.6 shows an example of  $a_f$ -resolved scattering profiles obtained on the EVA instrument. The angle of incidence was chosen below the critical angle of total reflection such that the scattering depth is less than  $1300\text{\AA}$  over the whole range of  $a_f$ -angles. Only 0.2 neutrons /sec. are scattered into the peak maximum showing the general low-intensity character of these experiments. The data were analyzed within the *Distorted Wave Born Approximation* using a model that accounts for surface roughness and a damaged crystalline toplayer of  $650\text{\AA}$ . This non-scattering layer has already been confirmed by the x-ray measurements and is due to the polishing process. Close to the Néel temperature the observed magnetic scattering from the remaining thin crystalline layer within the scattering depth, decayed significantly faster than similar bulk scattering.

To celebrate the 25th anniversary of the first proposal for neutron backscattering spectroscopy by Maier-Leibnitz an Internal Scientific ILL Report, 91 HE 22G, has been produced. It is entitled "Review of the Applications of Backscattering Techniques in Neutron and X-Ray Scattering" and contains sections on the different types of instruments, the appropriate theory and applications together with a detailed list of references.

Away from neutron based research an experimental project belonging to College 9A and undertaken at the Max Planck Institute for High Magnetic Fields, Grenoble has been completed. This work, on the Cotton-Mouton effect of ionic solutions, has yielded the first systematic investigation of the concentration dependence of the electro-optic properties of solvated ions. Information of great interest to those in the scattering community who study the degree of solvation of ions in aqueous solution.

Secretary: J. Williams

## Molecular Motions in Urea Inclusion Compounds

F. Guillaume\*, K. D. M. Harris\*\* and A. J. Dianoux\*\*\*

### Introduction

When long-chain molecules such as n-alkanes, carboxylic acids,  $\alpha,\omega$ -dihaloalkanes and others are co-crystallized with urea from an appropriate solvent, crystalline urea inclusion compounds are formed (1). In these inclusion compounds (2), the hydrogen-bonded network of urea molecules (hereafter called the "host") contains essentially "infinite", parallel tunnels of approximate diameter 5.25 Å, in which the "guest" molecules are trapped in an essentially fully extended conformation (Fig. 1). Because the inter-tunnel distance is ca. 8.2 Å, lateral guest-guest interactions are weak compared with the corresponding interactions in the "pure" crystalline phases of the guest molecules. Another interesting structural property of the urea inclusion compounds is the incommensurability between the periodicities of the host and guest substructures along the tunnel direction (3). Since their reported discovery in 1949 (4), these compounds have been studied extensively as prototypical materials for the analysis of dynamic and conformational properties of alkyl chains constrained in one-dimensional environments.

The n-alkane/urea inclusion compounds are known to undergo a phase transition from a low-temperature (LT) orthorhombic phase to a high-temperature (HT) hexagonal phase at a temperature that depends on the length of the guest molecule. Early  $^1\text{H}$  NMR studies (5) revealed the existence of large amplitude reorientations of the guest molecules about the tunnel axis in the HT phase. Furthermore, recent  $^2\text{H}$  NMR results (6) on hexadecane- $d_{34}$ /urea- $h_4$  have shown that an additional flexibility of the terminal  $-\text{CH}_2-\text{CH}_3$  groups is effective. Until now, however, dynamical models have generally been based on  $2\pi/6$  jumps of the rigid "all-trans" alkane molecules - an intuitively plausible motional model given the hexagonal symmetry of the host tunnel in the HT phase. Although translation of the guest molecules along the tunnel is also plausible (7), most studies of the dynamic properties of urea inclusion compounds have neglected any consideration of this motion.

Considerable progress has been made recently towards understanding the structural properties of the guest species in urea inclusion compounds, and room temperature X-ray diffraction studies of urea inclusion compounds containing a wide range of functionalized n-alkane guests have been reported (3,8,9). These studies have revealed new types of three-dimensional ordering (i.e. intra- and inter-tunnel ordering) of the guest molecules in the HT phase, although most single crystals also contain regions in which the guest molecules are ordered only in one dimension, along the tunnel axis

(c-axis). For example, the n-alkane/urea inclusion compounds are predominantly only one-dimensionally ordered, whereas the  $\text{Br}(\text{CH}_2)_n\text{Br}$ /urea inclusion compounds (8) exhibit a characteristic three-dimensionally ordered packing arrangement with

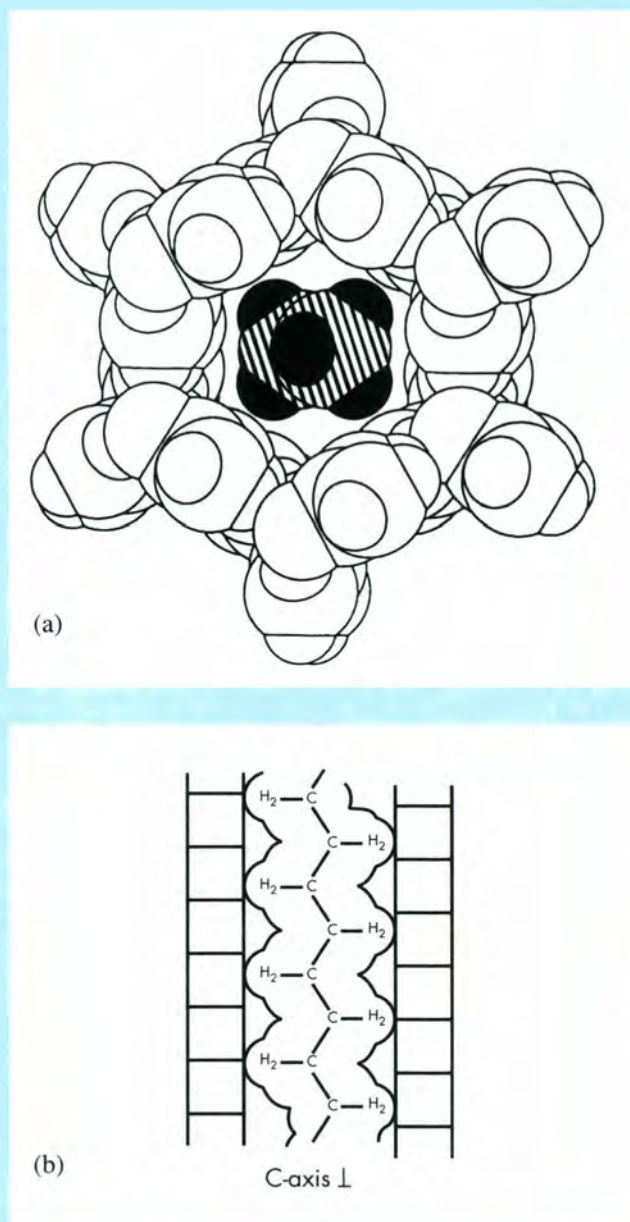

Fig. 1: (a) Structural representation (with van der Waals radii) of a single tunnel within the hexadecane/urea inclusion compound, viewed along the tunnel axis.

The urea substructure has been determined from single-crystal X-ray diffraction data (3).

(b) Schematic model of an n-alkane/urea inclusion compound viewed perpendicular to the tunnel axis.

$\Delta_g = c_g/3$  ( $\Delta_g$  and  $c_g$  are defined in Fig. 2). Thus  $\Delta_g$  increases with molecular length (i.e. as  $c_g$  increases), in contrast to the situation (9) for urea inclusion compounds containing diacyl peroxide guest molecules (which exhibit a constant value of  $\Delta_g = 4.6 \text{ \AA}$  irrespective of the value of  $c_g$ ).

In order to improve our fundamental understanding of the structural and dynamic properties of urea inclusion compounds, a collaborative research programme, involving a wide range of experimental techniques (including  $^2\text{H}$  NMR spectroscopy, neutron scattering, polarized Raman scattering, infrared spectroscopy, and X-ray diffraction) has been developed between our laboratories, with current emphasis on incoherent quasielastic neutron scattering (IQNS). So far, IQNS studies of n-alkane/urea and  $\alpha,\omega$ -dibromoalkane/urea inclusion compounds have been carried out, with a view to: (a) comparing the dynamic properties of the guest molecules constrained in the one-dimensional urea tunnels with those of the same molecules in their "pure" crystalline phase (e.g. pure crystalline nonadecane (10)); (b) comparing the dynamic properties of n-alkanes in urea tunnels with those of the functionalized (e.g. terminally brominated) n-alkane guests (c) investigating the temperature-dependence of the dynamic properties of the guest molecules in urea inclusion compounds, with particular interest in how these properties differ in the LT and HT phases.

#### Molecular motions in n-alkane/urea and $\alpha,\omega$ -dibromoalkane/urea inclusion compounds

Single crystals (ca. 5 mm long) of  $\text{CH}_3(\text{CH}_2)_{17}\text{CH}_3/\text{urea-d}_4$  and  $\text{Br}(\text{CH}_2)_n\text{Br}/\text{urea-d}_4$  ( $n=8-10$ ) inclusion compounds were arranged in aluminium containers such that the urea tunnel axes (c-axes) of all crystals were parallel. The orientations of the crystals with respect to rotation about this axis were random. IQNS experiments were performed on these semi-oriented polycrystalline samples using two experimental geometries: (a) with momentum transfer vector  $\mathbf{Q}$  parallel to the urea tunnel axis (denoted  $Q_{\parallel}$ ); and (b) with momentum transfer vector  $\mathbf{Q}$  perpendicular to the urea tunnel axis (denoted  $Q_{\perp}$ ). With these two sample orientations, motions of the guest molecules along the tunnel (assessed from  $Q_{\parallel}$  spectra) can be investigated separately from reorientational motions of the guest molecules about the tunnel axis (assessed from  $Q_{\perp}$  spectra). Preliminary experiments on the  $\text{CD}_3(\text{CD}_2)_{14}\text{CD}_3/\text{urea-h}_4$  inclusion compound have also been performed, in order to investigate the dynamics of the host (urea) molecules.

The experimental results obtained (11-15) can be summarized as follows :

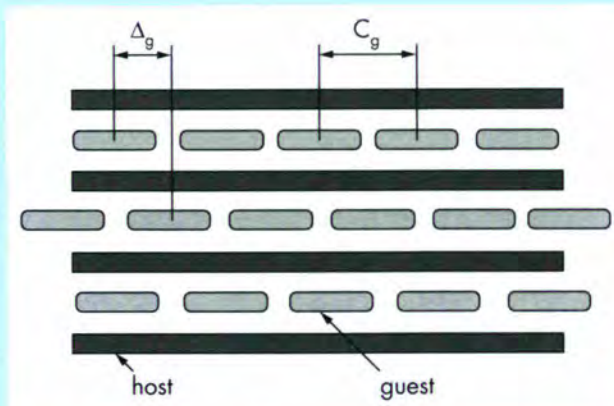

Fig. 2: Definitions of  $c_g$  and  $\Delta_g$ .

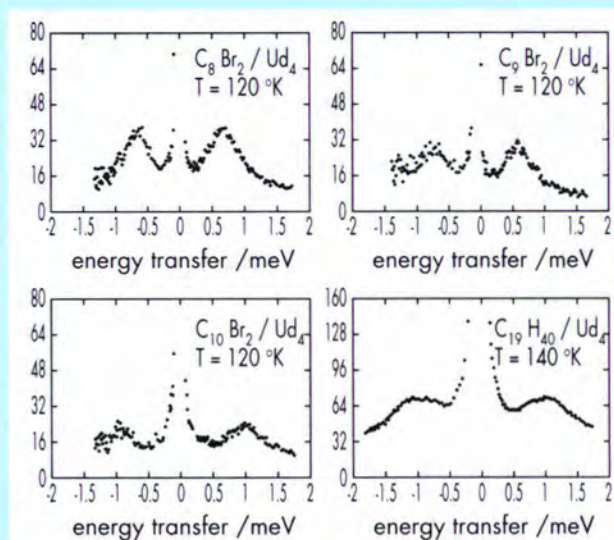

Fig. 3: Spectra recorded for the LT phases of  $\text{Br}(\text{CH}_2)_n\text{Br}/\text{Urea-d}_4$  (denoted  $\text{C}_n\text{Br}_2/\text{Ud}_4$ ) and  $\text{C}_{19}\text{H}_{40}/\text{Urea-d}_4$  ( $\text{C}_{19}/\text{Ud}_4$ ) in the  $Q_{\parallel}$  geometry ( $2\theta = 90^\circ$ ). The scale expansion is  $\times 100$ .

#### (i) Motions of the guest molecules in the LT phase

The  $Q_{\perp}$  spectra display a purely elastic scattering within the instrumental resolution, (60  $\mu\text{eV}$  and 80  $\mu\text{eV}$  on IN5 and IN6, respectively) indicating that, in the LT phase, no reorientational motions of the guest molecules are effective on the instrumental timescale.

In the  $Q_{\parallel}$  spectra, side-peaks at about 1 meV can be observed in addition to the elastic line (Fig. 3). These inelastic peaks, first observed by Boysen et al. (13) but assigned by these workers to librational motions, are best attributed to an acoustic type mode involving longitudinal displacements of the hydrogen atoms of the guest molecule.

## ii) Motions of the guest molecules in the HT phase

As discussed below, both translation of the guest molecules along the tunnel and reorientation about the tunnel axis are effective on the same timescale in the HT phase.

The reorientational motion about the tunnel axis cannot be described as discrete  $2\pi/6$  jumps of the rigid guest molecule in the temperature range investigated, but displays a diffusive-type behaviour. An incoherent scattering law based upon uniaxial rotational diffusion in a one-fold cosine potential (12) has been used successfully to analyse the  $Q_{\perp}$  spectra, as shown in Fig. 4. In this motional model, the effective barrier height  $V_0$  is a fitted parameter and is temperature dependent. The best-fit values for  $V_0$  and for the rotational diffusion coefficient  $D_r$  are listed in Table 1.

In the  $Q_{\parallel}$  spectra (Fig. 4), the side-peaks broaden considerably in the HT phase due to damping of the oscillations (discussed above for the LT phase), and there is a strong quasielastic broadening attributed to translational motions. To analyse these spectra, we have developed a model (12) in which the motion of the guest molecule along the tunnel axis is separated into two parts: (a) motion of the molecular centre of mass (translatory); and (b) motion of the hydrogen atoms relative to the centre of mass (oscillatory). These motions

are not coupled in time, the frequency of the oscillator (ca. 1 meV) being an order of magnitude larger than the quasielastic broadening due to the diffusive restricted translations (ca. a few tens of  $\mu\text{eV}$ ). The best-fit values of the translation length ( $L$ ) and the diffusion coefficient ( $D_t$ ) are listed in Table 1.

**Table 1:** Best fit parameters for the models of uniaxial rotational diffusion in a one-fold cosine potential ( $Q_{\perp}$ ) and of restricted translational diffusion ( $Q_{\parallel}$ ) obtained from the spectra in the HT phases of the  $\text{Br}(\text{CH}_2)_n\text{Br}/\text{Urea-d}_4$  (denoted  $\text{C}_n\text{Br}_2/\text{Ud}_4$ ) and  $\text{C}_{19}\text{H}_{40}/\text{Urea-d}_4$  ( $\text{C}_{19}/\text{Ud}_4$ ) compounds.

Compound	T / K	$V_0$ / kJ mol <sup>-1</sup>	$D_r$ / ps <sup>-1</sup>	$L$ / Å	$D_t$ / 10 <sup>-6</sup> cm <sup>2</sup> s <sup>-1</sup>
$\text{C}_8\text{Br}_2/\text{Ud}_4$	240	7.6	0.23	2.1	5.8
$\text{C}_9\text{Br}_2/\text{Ud}_4$	240	9.5	0.20	1.6	2.4
$\text{C}_{10}\text{Br}_2/\text{Ud}_4$	240	9.6	0.19	1.8	2.7
$\text{C}_9\text{Br}_2/\text{Ud}_4$	160	15.9	0.16	0.9	0.7
$\text{C}_{19}/\text{Ud}_4$	160	10.6	0.12	1.1	1.1
$\text{C}_{19}/\text{Ud}_4$	306	4.8	0.28	2.7	15.2

## (iii) Motions of the host molecules in the HT phase.

The dynamics of the urea molecules have been investigated (14) using a polycrystalline sample of  $\text{CD}_3(\text{CD}_2)_{14}\text{CD}_3/\text{urea-h}_4$  (Fig. 5). At 300 K, we conclude that no motions, on a  $\tau < 50$  ps timescale, of the urea molecules are effective and it is therefore clear that, at this temperature, the dynamics of the host and the guest components of the urea inclusion compound are uncorrelated. Note that the very low intensity quasielastic broadening evident on Fig. 5 arises from the residual  $^1\text{H}$  impurities and from the  $^2\text{H}$  in the perdeuterated hexadecane molecules.

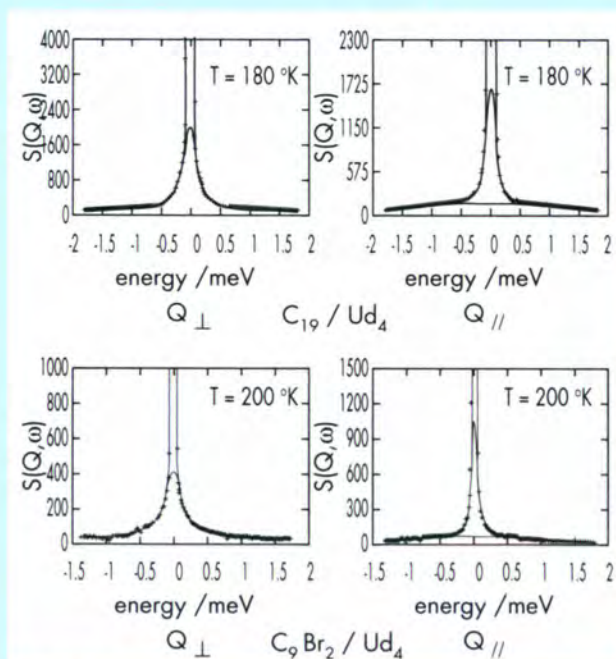

**Fig. 4:** Spectra recorded for the HT phases of  $\text{Br}(\text{CH}_2)_n\text{Br}/\text{Urea-d}_4$  (denoted  $\text{C}_n\text{Br}_2/\text{Ud}_4$ ) and  $\text{C}_{19}\text{H}_{40}/\text{Urea-d}_4$  ( $\text{C}_{19}/\text{Ud}_4$ ) in the  $Q_{\parallel}$  and  $Q_{\perp}$  geometries. The full lines are the fit with the dynamical model developed in reference 12. The scale expansion is  $\times 4$ .

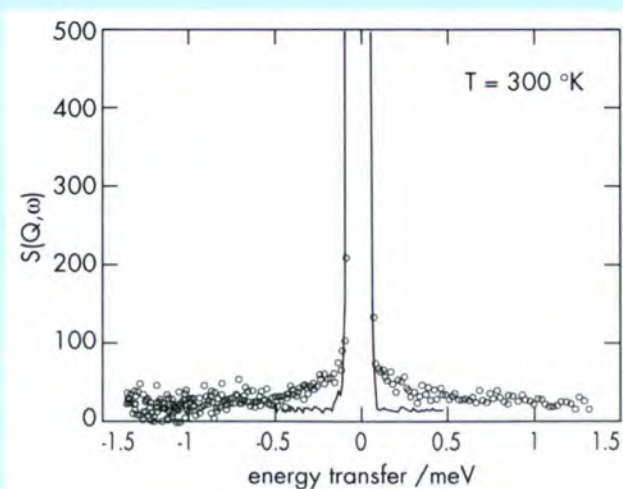

**Fig. 5:** Spectrum at  $2\theta = 120^\circ$  of the hexadecane- $\text{d}_{34}/\text{Urea-h}_4$  inclusion compound at 300 K compared to the vanadium standard at 5 K. The scale expansion is  $\times 40$ .

## Discussion

Our results from IQNS spectroscopy clearly demonstrate the existence of fast oscillatory, translational diffusive and rotational diffusive motions of the guest molecules within the one-dimensional tunnels of the urea host structure. These observations are to be compared with previous reported dynamic models based upon the assumption that the guest molecules undergo discrete  $2\pi/6$  jumps about the tunnel axis. It is tempting (and probably adequate) to "combine" the translational and reorientational components of the motion and describe the dynamic behaviour of the guest molecules in the HT phase as "screw-like" (16). However, the motional models that have been developed have not considered correlations between these translational and rotational components but the fits shown in Fig. 4 are nevertheless satisfactory. It is therefore not justified, at present, to state that the motion can definitely be described as "screw-like". It is also relevant to note that it was not necessary to introduce additional motions such as torsional oscillations involving the  $-\text{CH}_2-\text{CH}_3$  or  $-\text{CH}_2-\text{Br}$  end-groups in order to satisfactorily fit the IQNS spectra. A detailed analysis of the end-group dynamics, via IQNS, will require selectively deuterated samples of the type  $\text{CH}_3\text{CH}_2(\text{CD}_2)_n\text{CH}_2\text{CH}_3/\text{urea-d}_4$  (however, a relatively large uncertainty in the results from such studies is likely, since the high  $^2\text{H}/^1\text{H}$  ratio in the guest molecule will result in a significant proportion of the total incoherent scattering arising from the  $^2\text{H}$  atoms). In such cases, it is essential to employ other experimental techniques (such as Raman scattering and  $^2\text{H}$  NMR spectroscopy), in conjunction with IQNS, in order to derive a detailed understanding of the dynamic properties. In particular, we have shown by Raman scattering that there is an appreciable proportion of gauche defects located near the chain ends of n-alkane (17) and  $\alpha,\omega$ -dibromoalkane (18) guest molecules in both the LT and HT phases.

## References

- [1] K. Takemoto and N. Sonoda, *Inclusion Compounds 2*, Academic Press London, 1984, p. 47.
- [2] A.E. Smith, *Acta Cryst.*, 1952, 5, 224
- [3] K.D.M. Harris and J.M. Thomas, *J. Chem. Soc., Faraday Trans.*, 1990, 86, 2985.
- [4] M.F. Bengen, *Ann.Chem.*, 1949, 565, 204
- [5] D.F.R. Gilson and C.A. McDowell, *Mol.Phys.*, 1961, 4, 125
- [6] K.D.M. Harris and P. Jonsen, *Chem.Phys.Lett.*, 1989, 154, 593
- [7] K. Fukao, H. Miyaji and K. Asai, *J. Chem. Phys.*, 1986, 84, 6360.
- [8] K.D.M. Harris, S.P. Smart and M.D.Hollingsworth, *J.Chem.Soc., Faraday Trans.* 1991, 87, 3423
- [9] K.D.M. Harris and M.D.Hollingsworth, *Proc. R. Soc. Lond. A*, 1990, 431, 245
- [10] F. Guillaume, J. Doucet, C. Sourisseau and A.J. Dianoux, *J.Chem.Phys.*, 1989, 91, 2555
- [11] F. Guillaume, C. Sourisseau and A.J. Dianoux, *J.Chem.Phys.*, 1990, 93, 3536
- [12] F. Guillaume, C. Sourisseau and A.J. Dianoux, *J.Chim.Phys. (Paris)*, 1991, 88, 1721
- [13] H. Boysen, F. Frey and H. Blank, *Mater. Sci. Forum*, 1988, 27/28, 123
- [14] K.D.M. Harris, F. Guillaume, S.P. Smart, C. Sourisseau and A.J. Dianoux, *J. Materials Chem.*, (submitted)
- [15] S.P. Smart, F. Guillaume, K.D.M. Harris, C. Sourisseau and A.J. Dianoux, *Physica B* (in press)
- [16] H. Boysen, F. Frey, H. Blank and G. Kearley, *ILL xpt. Report*, 1990, No 9-06-600
- [17] A. El Baghdadi, F. Guillaume, R.M. Cavagnat and C. Sourisseau (in preparation)
- [18] S.P. Smart, K.D.M. Harris, F. Guillaume and A. El Baghdadi, *Mol. Cryst. Liq. Cryst.* 1992, 211, 157.

\* Laboratoire de Spectroscopie Moléculaire et Cristalline, Université de Bordeaux 1, CNRS URA 124, 33405 Talence Cedex, France

\*\* Department of Chemistry, University of St. Andrews, St. Andrews, Fife KY16 9ST, Scotland

\*\*\* Institut Laue-Langevin, B.P. 156X, 38042 Grenoble Cedex, France

## Large Molecules

### Members of the College

E. Almaric	J.F. Legrand
P. Chieux	A. Lied
A. Degeyer	P. Lindner
B. Farago	R. Oeser
B. Frick	F. Rieutord
K. Ibel	V. Rodriguez
C. Lartigue	P. Terech

### Scientific Highlights in 1991

#### Ferroelectric Soft Mode in P(VDF-TrFE) copolymers above $T_c$

Random copolymers of vinylidene fluoride and trifluoroethylene with typical composition 70/30 exhibit a ferroelectric transition with a large enthalpy change. It has been previously shown from NMR and incoherent neutron scattering studies that this is due to the conformationally disordered nature of the paraelectric phase.

For the investigation of the structure and of the dynamics of this disordered phase we have used a deuterated specimen of P(dVDF-TrFE) copolymer synthesized at A.T. & T. Bell Labs that we have oriented by rolling. In a first experiment, the diffuse coherent scattering above the Curie temperature has been analyzed using the polarized neutron diffractometer D7. The weakness of the longitudinal registry between adjacent chains gives rise to a diffuse (and almost elastic) streak at the (001) Bragg position. This diffuse reflection at  $q_z = 2.75 \text{ \AA}^{-1}$  extends over typically  $1 \text{ \AA}^{-1}$  along  $q_x$  and  $q_y$  consistent with a nematic-like (local) structure (see Figure 1). Indeed, in the (hk0) reciprocal lattice plane, narrow Bragg peaks confirm the 2D long range hexagonal order of the centres of mass of the chains but diffuse scattering is also observed at the feet of the peaks along  $q_x$  and  $q_y$ . The diffuse scattering in the (hk0) plane can be attributed to acoustic phonons propagating perpendicular to the chain axis but also to dipolar fluctuations with the symmetry of the ferroelectric polarization (perpendicular to the chain axis).

This quasi-elastic diffuse scattering was resolved using the neutron spin echo instrument IN11 in a monochromatic mode ( $\lambda = 5.2 \text{ \AA}$ ,  $\Delta\lambda = 2\%$ ). On the flank of the Bragg peak a relaxational soft mode has been observed with a half-width of  $0.5 \text{ \mu eV}$  at  $400 \text{ K}$  which decreases down to  $0.15 \text{ \mu eV}$  at  $330 \text{ K}$  close to the ferroelectric transition (see Figure 2). The  $\mathbf{q}$ -dependence of this mode and its scaling with the dielectric anomaly confirm that it can be attributed to dipolar transverse excitations in the (hk0) plane which initiate the ferroelectric ordering although complete ordering is ultimately achieved through a first order phase transition.

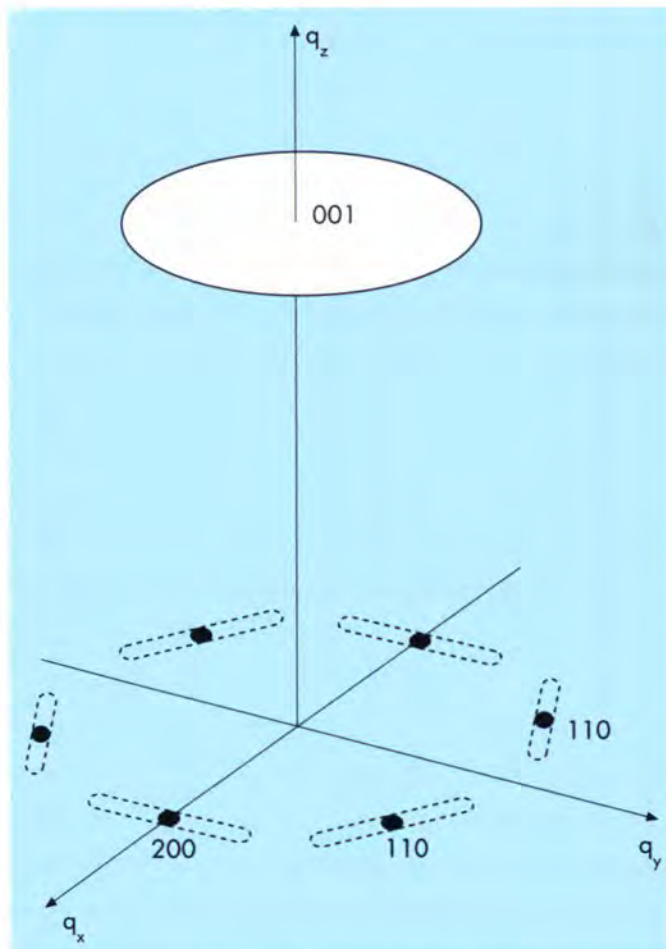

Fig. 1: Reciprocal lattice of P(VDF-TrFE) in the paraelectric phase showing the (001) diffuse streak and the Bragg and diffuse scattering in the (hk0) plane.

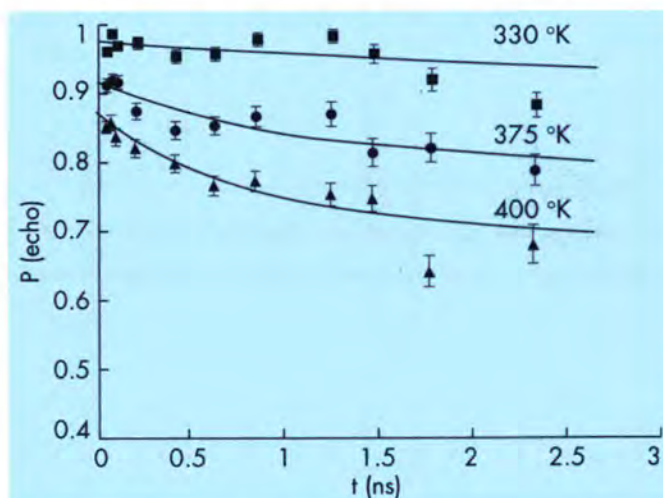

Fig. 2: Neutron spin-echo analysis of the diffuse scattering at (2,0,5,0). Note the rather large elastic background (Bragg peak contamination) due to the mosaic texture of the sample.

### Quasi-elastic neutron scattering in polymeric networks.

Quasi-elastic neutron scattering has been instrumental in the understanding of the structure of polymer gels. It is known that in polymer solutions the osmotic attraction between polymer and solvent is generally stronger than in the equivalent cross-linked gel, a phenomenon that has not been fully understood. Spontaneous concentration fluctuations in these systems are governed by the osmotic modulus  $M_{OS}$ , and their relaxation rate at low  $Q$ -values is determined by the ratio  $D = M_{OS}/f$ , where  $f$  is a friction coefficient between polymer and solvent. A polydimethyl siloxane network swollen in toluene was compared with the equivalent uncross-linked solution. At high  $Q$ , where the relaxation starts to become dominated by the mobility of the statistical units, the spin-echo measurements gave identical results for solution and gel: it follows that the observed differences are not due to a modification of the structure of the statistical units. Large static non uniformities in the gel structure influence the apparent low- $Q$  response of the spin echo decay by adding a constant background; when this effect is taken into account, the gel and the solution become indistinguishable, yielding excellent agreement with the results of quasi-elastic light scattering from this system. A simple model of the static non uniformities has been proposed, based on small-angle elastic neutron scattering measurements. All the observed differences between gel and solution seem to be explainable in terms of these frozen fluctuations, which modify each average property measured.

Further insight into gels was provided by the spin echo technique in an investigation of the response to uniaxial stretching. Recent observations elsewhere of stretched swollen gels using quasi-elastic light scattering concluded that the diffusion coefficient  $D$  is strongly anisotropic. Light scattering measurements are sensitive, however, to artefacts due to partial heterodyning, thus distorting estimates of  $D$ . The neutron spin echo technique, where the total wave-

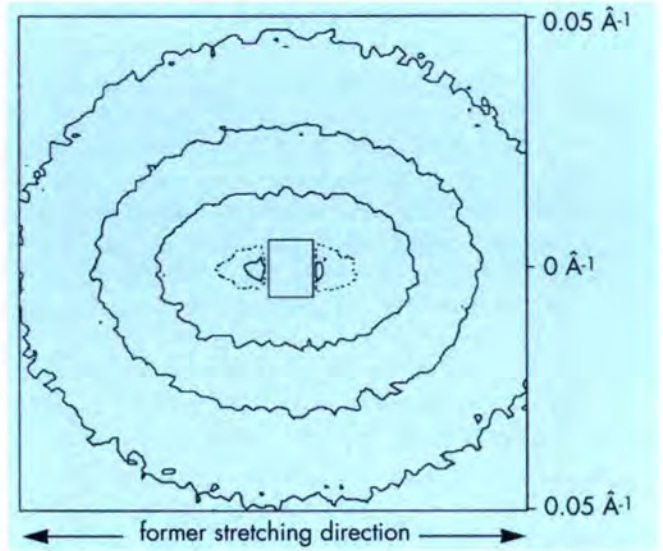

Fig. 4: Spectrum of the isotropic sample after relaxation taken with the beam in the centre. The edge of the detector corresponds to  $0.05 \text{ \AA}^{-1}$ . The contours are 4, 8, 16, 32 (---) and  $40 \text{ cm}^{-1}$  towards the center.

function of the neutrons is essentially phase incoherent, is free of this uncertainty. For the sample of polydimethyl siloxane investigated in our experiment, the diffusion coefficients parallel and perpendicular to the stretching axis were indistinguishable: no anisotropy in  $D$  is detected, even for uniaxial extensions up to 40%. (Laboratoire de Spectrométrie Physique, Université Joseph Fourier de Grenoble).

### Gelation in polymer networks

Interpenetrating polymer networks (IPN's i.e. a host network containing a physically entangled second network) are of general interest because of their enhanced mechanical properties. The beginning of the buildup of the second network was monitored with small angle neutron scattering. Small deuterated chains were crosslinked among themselves within an uniaxially stretched hydrogenated matrix. The kinetics of the growth of the deuterated aggregates is determined by the mobility of the small chains. The increase in size and mass of the clusters (Fig. 3) can be described with the model of DLA (diffusion limited aggregation) taking into account the chemical reactivity of the small chains.

During the whole reaction the scattering is anisotropic due to the deformation. After relaxation of the matrix the anisotropy persists (Fig. 4). This indicates a possibility to produce elastomers with anisotropic properties.

### Shear induced particle structures of concentrated polymer dispersions

Based on various light and neutron scattering experiments on sheared dispersions, where distinct changes of the particle structures had already been observed with increasing shear rate, the viscosity transitions of these dispersions have been attributed to flow induced changes of

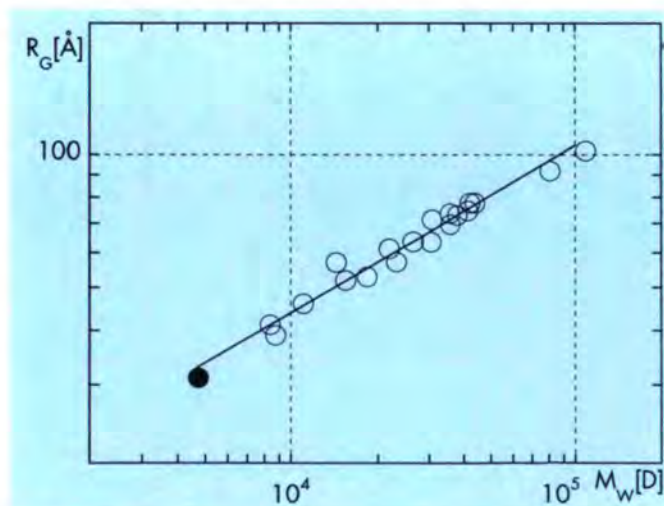

Fig. 3: Radius of gyration of the clusters vs. molecular weight as measured by SANS. The slope of the line is 0.38 (DLA:0.4).

the spacial particle arrangements: the shear *thinning* behaviour of a dispersion is mainly due to changes in the local structure without formation of a long range particle superstructure. The vectors connecting the centres of two adjacent particles are oriented with increasing shear rate towards the direction of flow which results in a decrease of the viscosity. If additionally a long range particle structure is built up, the cooperativity of the particle movements yields a further decrease of the viscosity. At a critical shear rate  $\dot{\gamma}_c$ , the disturbing hydrodynamic interactions finally cause a break down of the ordered particle superstructure and, consequently, a more random packing of the particles, resulting in a steep increase of the viscosity (shear *thickening* behaviour).

Shear induced particle structures of rheologically well characterized, concentrated polymer dispersions were investigated by SANS at the instrument D11 of the ILL in a wide range of deformation rates, using a quartz slit die apparatus of BASF AG, which could be tilted with regard to the neutron beam and with the ILL-Couette type shear apparatus. The dispersions consist of electrostatically stabilized styrene-ethylacrylate-copolymer spheres in glycol or water. Their viscosity functions show pronounced *shear thinning* and strong *shear thickening* versus shear rate as measured over nearly 8 orders of magnitude of the shear rate by various rotational rheometers and by capillary rheometry (cf. Fig. 5).

The SANS patterns of nearly monosized 165 nm particles at 52.3 % solid in glycol (sample A5G) exhibit in the shear thinning regime distinct hexagonal maxima superimposed on the (amorphous) circular halo and also in a second ring indicating the formation of a long range particle superstructure (cf. Fig. 6 a, b) as measured with the slit die at a wall shear rate  $\dot{\gamma} = 10^{-4} \text{ s}^{-1}$ . The intensity of these maxima is changed in a systematic way when the slit die plane is tilted. These changes of the scattering pattern can in principle be used to clarify the underlying 3-dimensional particle structure.

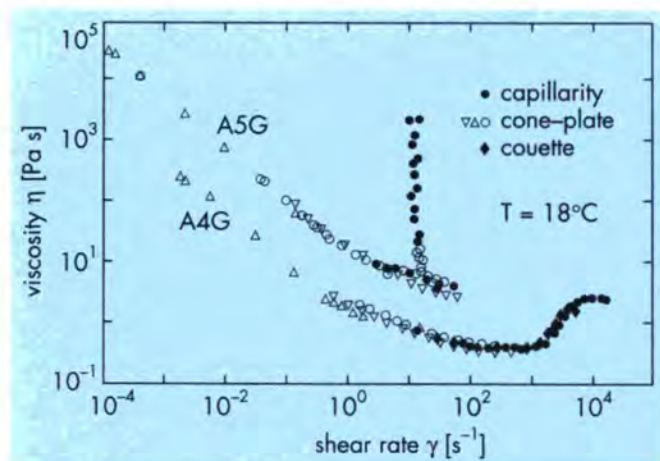

Fig. 5: Shear viscosity of colloidal dispersions glycol based dispersions of styrene-ethylacrylate-copolymer spheres A4G (165 nm mean diameter, 43.4% solid) and A5G (165 nm mean diameter, 52.3% solid).

Fig. 6 (a,c,d) also shows the change of the scattering pattern of this sample by variation of the shear rate as measured with the slit die in standard position. With increasing shear rate these maxima disappear and an anisotropy of the halo intensity shows up: an intensity increase in flow direction at small angles is observed in the shear thickening regime at a wall shear stress of 4000 Pa (wall shear rate  $\dot{\gamma} = 12 \text{ s}^{-1}$ , Fig. 6 d). It is evident that the hexagonal superstructure only exists in the shear thinning region.

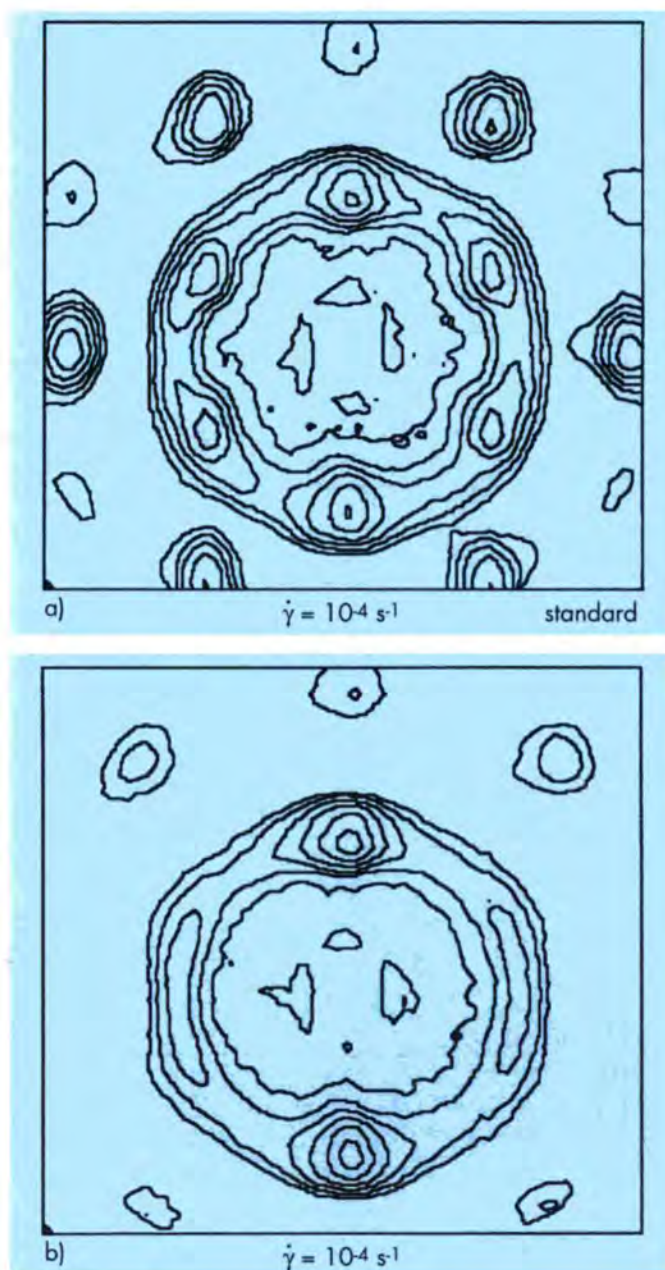

Fig. 6: D11 contour plots ( $L=20\text{m}$ ,  $l=1.2 \text{ nm}$ ) for sample A5G in plane Poiseuille flow at different wall shear rates and various orientations of the slit die.

a) standard position: shear plane perpendicular with respect to primary beam, wall shear rate  $\dot{\gamma} = 10^{-4} \text{ s}^{-1}$ ,  
 b) shear plane tilted at  $44^\circ$  with respect to primary beam,  $\dot{\gamma} = 10^{-4} \text{ s}^{-1}$ .

Similar structural changes are found at 43.5% solid for 165 nm particles (sample A4G). The results obtained in Couette flow are in qualitative agreement with the slit data but show much sharper intensity maxima. (Ludwigshafen, TU Berlin, ILL).

### Silica particles

Octadecyl coated silica particles provide a system which can be obtained without much polydispersity ; moreover, they do not change their shape as a function of concentration. These properties allow one to study the structure factors of such solutions, because they can be easily separated from the form factors of the particles. Two examples for the application of such systems are investigations of the short-ranged attraction between identical particles and of the behaviour of mixtures of particles of different size. In solvents where contacts between the surface-grafted hydrocarbons is preferred with respect to an interaction of the hydrocarbons with solvent atoms, one can observe a thin attractive potential which is a function of temperature. This stickiness of the spheres can be well approximated by model calculations. Whilst the structure factors of identical spheres behave like hard spheres, a marked deviation from hard sphere behaviour can be observed in the mixture and can be qualitatively explained with an effective attraction of unequal particles in the mixture (Utrecht, ILL).

### Cubic phases in oil-water-amphiphiles systems

There has been recently a growing interest for the investigation of the cubic phases formed in systems of oil, water and amphiphiles, and many different structures have been found. The Pn3m and Im3m cubic phases found in the system didodecyldimethylammonium bromide/water/octane are examples of cubic phases based on an infinite bilayer of amphiphiles. The bilayer contains the oil in its middle part and can be described by well-known infinite periodic minimal surfaces.

Other structures for oil-water bicontinuous cubic phases can be found, involving a monolayer of amphiphiles forming an infinite surface between two continuous and mutually intertwined networks of oil and water, a situation which can be explored at different oil/water compositions.

Cubic structures with cellular topologies form another important class. Depending on the nature of the interfaces, various situations can occur. For systems with strong preferred radius of curvature, the cubic organization will mainly arise from spherical droplets or cylinders of oil or water optimizing their packing. For systems with lower preferred radius of curvature, the concept of hard sphere is questionable and the cubic organization will mainly arise from interactions between fluid layers. Two new cubic structures of space-group Pm3n and Fd3m have been derived from the analysis of the situation of fluid films separated by curved interfaces in terms of geometrical frustration. These cellular structures are based on space-filling assemblies of non-regular polyhedra, with the faces of the polyhedra supporting layers of one medium.

Experimental results have been obtained on a system of oil, water and sodium dodecylsulfate, showing the occurrence of two cubic phases of space group Pm3n (unit cell 270 Å) and Fd3m (unit cell 385 Å). These phases have been studied by small-angle X-rays and neutrons diffraction (ILL/EMBL). Data obtained on powder samples have been compared to different structural models. A good agreement is obtained considering water layers delimiting the cells of the space-filling assemblies of the type proposed above.

Secretary: P. Terech

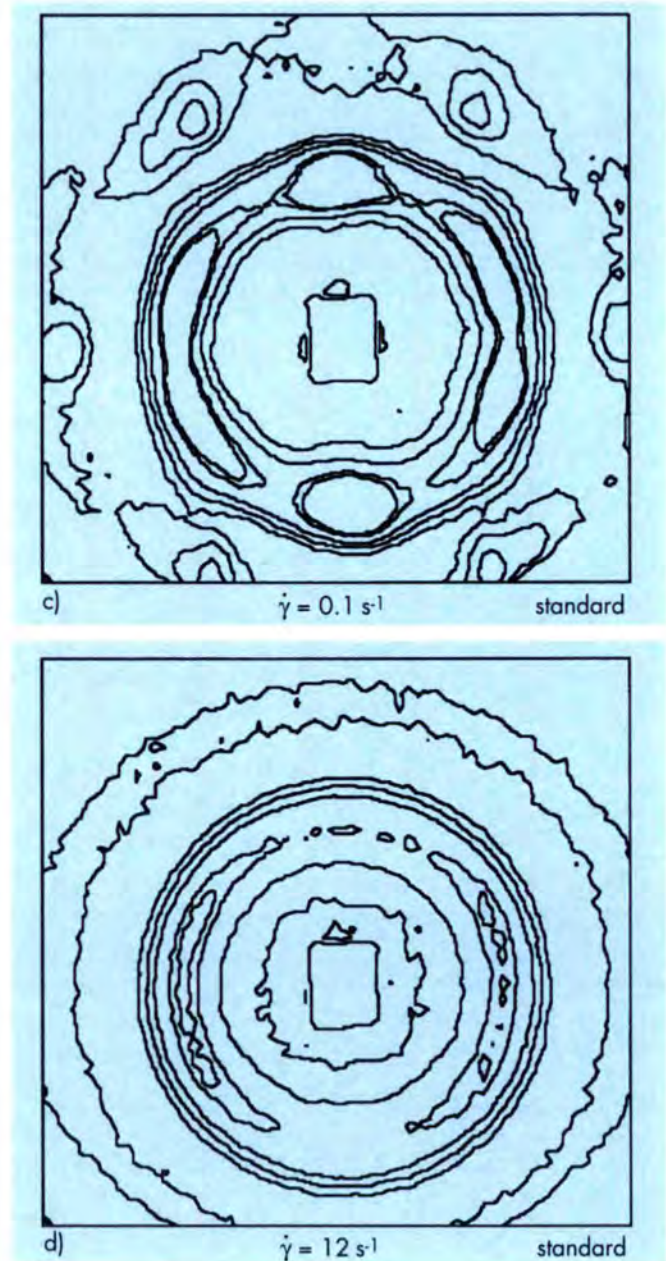

Fig. 6:  
c) standard position,  $\dot{\gamma} = 0.1 \text{ s}^{-1}$ ,  
d) standard position,  $\dot{\gamma} = 12 \text{ s}^{-1}$ .

## A new class of "living polymers" in organic solvents. P. Terech

### Physical gels: structure and properties

Aggregation of surfactants in organic solvents is driven by dipolar interactions instead of hydrophobic interactions in aqueous systems. In some cases, very anisometric aggregates are obtained. Such elongated structures are found in surfactant organogels [1]. A specific interaction (for instance, hydrogen bonding) is involved in the intra-chain aggregation mechanism of the amphiphilic molecules. The typical rheological properties of these gel phases are due to the inter-chain interactions. The chains (more or less rigid) are overlapping and form an infinite and three-dimensional network. According to the stability of the junction zones [2], strong and weak gelations are distinguished. In the former case, a sharp sol-gel threshold resulting from the percolation of the aggregates is observed. The gel phase exhibits elasticity even at zero frequency which characterizes the stable but thermoreversible solid-like 3d network. Again, a specific interaction is often at the origin of the stability of the chain crosslinks: hydrogen bonding can give microcrystalline nodes (see the example of 12-hydroxystearic organogels [3]). By contrast, for weak physical gels, the transient network is formed by entangled worm-like aggregates. The equilibrium statistics and dynamics of these systems can show analogies with usual polymer solutions in the so-called semi-dilute regime. Examples are usually found with aqueous systems (see for instance the salted solutions of cetylpyridinium bromide [4]). Some discrepancies of the data with the scaling laws of the semi-dilute polymers have suggested that the surfactant aggregates are dynamic species which can undergo chain breakages and recombination processes. This situation is described by the theoretical model of "living polymers" by Cates [5] and where the chain scission/reformation process provides an additional mechanism for stress relaxation.

We present here such a viscoelastic system which is the first example of a "living polymer" in a pure apolar organic solvent.

### Living polymers: theory

- By contrast to ordinary polymers, the molecular weight distribution of worm-like species made up with aggregated surfactants is a thermal equilibrium (these systems can be referred to as "equilibrium polymers"). The scaling theory applied to semi-dilute solutions of such aggregates (in absence of rings) predicts an exponential distribution of the micellar lengths  $L$ .

$$\bar{L} \approx \phi^y \exp\left(\frac{E_{\text{scis}}}{2kT}\right)$$

where  $y \approx 0.6$ ,  $k$  is the Boltzmann constant,  $\phi$  the total volume fraction,  $E_{\text{scis}}$  is the energy to break up an aggregate in two fragments. For semi-dilute solutions, some quantities like  $\eta_0$  (zero shear viscosity),  $G'$  (storage modulus), the longest viscoelastic relaxation time  $\tau$ , the cooperative diffusion coefficient  $D$  and  $\xi$  (correlation length) follow scaling laws with the volume fraction.

- In the case of "living polymers", the dynamical properties are detailed by the Cates' model proposed on the basis of three assumptions: (i) the breakage occurs with a fixed uniform probability per unit length of the aggregate, (ii) successive breakage and recombination events are uncorrelated, (iii) the dynamics of an aggregate end on the time scale of its recombination is mainly that of reptation (gradual disengagement of a chain from a tubelike environment by curvilinear diffusion along its own contour). Within these conditions, the ratio  $\zeta$  of the average time  $\tau_{\text{break}}$  before a chain breakage over the reptation time  $\tau_{\text{rep}}$  of a hypothetical unbreakable chain of length  $L$  determines the various regimes encountered. For a simplified description, the persistence length  $l$  of the aggregate is taken lower than the mesh-size  $\xi$  of the network.

Briefly, when  $\zeta = \frac{\tau_{\text{break}}}{\tau_{\text{rep}}} \ll 1$ ,

the kinetics of breakage is rapid on the time scale of reptation and the terminal time  $\tau$  of the stress relaxation is a single exponential.

$$\tau \approx (\tau_{\text{break}} \tau_{\text{rep}})^{1/2}$$

This remarkable situation is not observed when  $\tau_{\text{break}}$  is long ( $\zeta \gg 1$ ).

Dynamic shear viscosity experiments permit a frequency dependent measurement of the  $G'(\omega)$  and the loss modulus  $G''(\omega)$ . It is convenient to use a Cole-Cole plot ( $G''$  vs  $G'$ ) because a pure exponential relaxation  $G(t) = e^{-t/\tau}$  appears finally as a semi-circle passing through  $G''(\omega) = 0$  and  $G''(\omega) = 1$  ( $G'$  and  $G''$  being respectively the real and imaginary parts of the dynamic shear modulus  $G^*$ ). This extreme behavior is that of a "Maxwell fluid" [7].

### Bicopper(II) tetracarboxylates in cyclohexane

The formula of the binuclear copper tetracarboxylates is  $\text{Cu}_2(\text{O}_2\text{C-R})_4$ , where  $R$  is either a linear ( $L$ ) or a branched aliphatic ( $S$ ) chain:  $R = \text{C}_{n-1}\text{H}_{2n-1}$ ,  $n$  being the total number of carbon atoms in a carboxylate ligand. Such binuclear molecules are constituted of two copper(II) ions bridged by four long chain carboxylate

groups (see figure 1), and thus have a disk-like mesogenic shape. Thermodynamical and structural studies have shown that these complexes exhibit a thermotropic transition from a lamellar crystalline phase to an hexagonal ordered columnar liquid crystalline phase [6] (discotic mesophase). Various homologues have been studied but we detail here the results for a substituted chain compound, the ethyl-2 hexanoate ( $R=C_7H_{15}=-CH(C_2H_5)(C_4H_9)$ ) noted as Cu<sub>2</sub>-S8, for which the "living polymers" have been discovered. When the tetracarboxylates are shaken in cyclohexane or methylcyclohexane, a blue jelly is obtained and the thickening effect is observed for low concentrations (ca 0.5%wt).

### Structure of the aggregates (SANS)

- The local structure of the aggregates is investigated by experiments on the D17 spectrometer of ILL. The scattering profiles are described in this Q-range (for  $1/\langle l \rangle < Q$ ) by the well-known formalism of scattering by rod-like aggregates [1,3]. The size and shape of the cross-section and the molecular weight per unit length of the elongated aggregate are deduced (Guinier analysis). For Cu<sub>2</sub>-S8, we find a diameter  $\varnothing=17.5\pm 0.8\text{\AA}$  and a number of molecule per unit length  $n_L=0.185$  molecules. $\text{\AA}^{-1}$ . This low value is compatible with an aggregation model where the molecules are stacked on top of each other along the axial direction of the rod. If the interdimer spacing within the Cu<sub>2</sub>-S8 aggregates of the jelly is identical to that in the discotic mesophase (4.7 $\text{\AA}$  [6]), the number n of molecules stacked per cross-

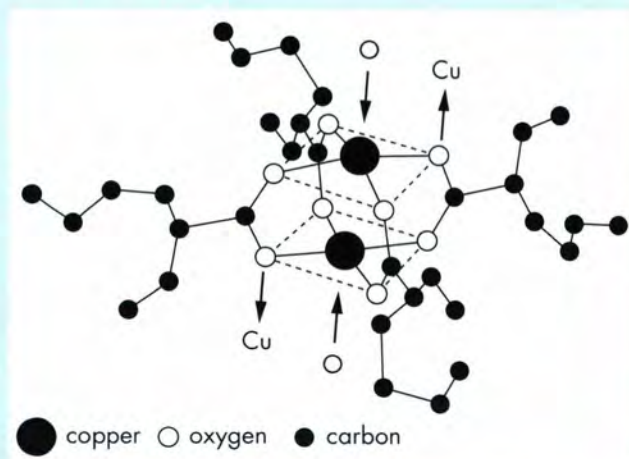

Fig. 1: Cu<sub>2</sub>-S8 molecule. Bond lengths and angles are arbitrary. The two parallel planes (dotted lines) show the square planar environment of each copper atom. Arrows indicate some of the possible coordination sites with the neighbouring molecules and define the symmetry axis of the rod-like aggregate. Aliphatic chains are represented in an arbitrary disordered conformation.

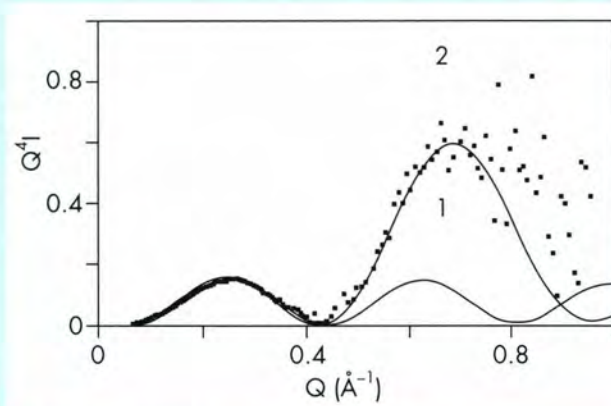

Fig. 2: Form factor oscillations in the Porod region. Cu<sub>2</sub>-S8/C<sub>6</sub>D<sub>12</sub> system,  $c= 8.7\%$ wt. The full line 1 is a calculation for fibres with an homogeneous circular cross-section following :  $r_0=8.7\text{\AA}$ ,  $\epsilon=0.05$ . Full line 2 concerns an inhomogeneous cross-section  $r_0=8.0\text{\AA}$ ,  $\epsilon=0.05$ ,  $K=20$  (ratio of the neutron contrast between the inner polar core of radius  $r=3\text{\AA}$  and the outer shell of hydrocarbon tails).

sectional repeating unit  $n=4.7n_L$  is then only one molecule. Each molecule is axially linked by both top and underside parts with the neighbours (Cu Cu direction) by coordination bondings between copper and oxygen atoms (figures 1 and 3) (for fig 3 see p. 88). With respect to the liquid-crystalline state, for which the intercolumnar spacing is 15.0 $\text{\AA}$ , the aliphatic chains are found slightly more expanded in the jellies. The structures in the jelly state are reminiscent with that of the related discotic thermotropic.

Experiments on the D17 and D16 spectrometers allow to analyze the intensity oscillations in the Porod region (figure 2) in terms of shape and homogeneity of the aggregate and support the aggregation mechanism above proposed. The cross-section is radially heterogeneous considering the difference of scattering length densities between the inner polar core (copper and oxygen atoms) and the outer hydrophobic shell (hydrocarbon chains).

- Additional experiments on the D11 spectrometer allow to probe the flexibility of the aggregate. The model of a persistence chain made up of a filament subjected to a bending procedure is used. According to the ratio of the contour length L over the persistence length  $\langle l \rangle$  the scattering functions of these so-called Kratky-Porod chains are known: the remarkable feature of the related structure factors is the occurrence of a  $Q^{-2}$  term in addition to the  $Q^{-1}$  term typical of the fibre-like behavior.

$$I(Q) \approx \frac{1}{Q} \left[ \frac{\pi}{L} + \frac{2}{3\langle l \rangle L Q} \right]$$

Detailed analysis is still under progress [9] but figure 4 shows such a cross-over between the  $Q^{-2}$  and a nearly  $Q^{-1}$  dependences of the scattered intensity  $I$  also observable for a very dilute jelly (estimation of  $\langle l \rangle \approx 200\text{\AA}$ ).

### Dynamics (rheology)

Dynamic shear viscosity measurements have been carried out in the linear regime with a Carri-Med CSL100 rheogoniometer with a cone and plane.

The thickening effect is very significant and can be characterized by the ratio  $\eta_r = \frac{(\eta_0 - \eta_s)}{\eta_s}$  where  $\eta_s$  is the viscosity of the solvent:

at  $T=25^\circ\text{C}$ ,  $\eta_r \approx 150000$  ( $C=2\%$ wt). The storage modulus  $G'(\omega)$  strongly increases with  $\omega$  and reaches a limiting plateau value at high frequencies (not shown [8]). The loss modulus  $G''(\omega)$  exhibits a well-defined maximum and then decreases to low values at high frequencies. These are typical features of a "Maxwell fluid": in the high frequency range the system behaves as an elastic body while it is a fluid at zero frequency. The pure single exponential relaxation is represented by the semi-circle of the Cole-Cole plot of figure 5. The plot shows that the description in terms of "living polymers" is correct and that the main parameter  $\zeta$  is probably not as low as assumed in the limiting case ( $\zeta \ll 1$ ) of the above mentioned Cates' theory.

Departures in the high frequency region are now analyzed in this context and a detailed study is under progress to obtain the volume fraction and temperature dependences of the relevant parameters (see theory). The exceptionally simple molecular architecture (1 molecule per cross-sectional unit) and the lack of the usual problems encountered in screening the electrostatic

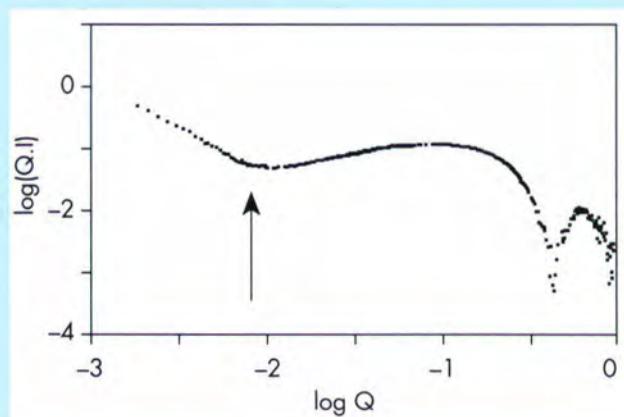

Fig. 4: Indicative scattering curve  $\log(QI)$  vs  $\log Q$  for the  $\text{Cu}_2\text{-S}_8/\text{D-cyclohexane}$  system ( $c=9.9\%$ wt). The arrow indicates the cross-over between the  $Q^{-2}$  and the  $ca Q^{-1}$  behaviors. In the high  $Q$  region, cross-sectional intensity oscillations due to the related form factor in the Porod region are clearly seen.

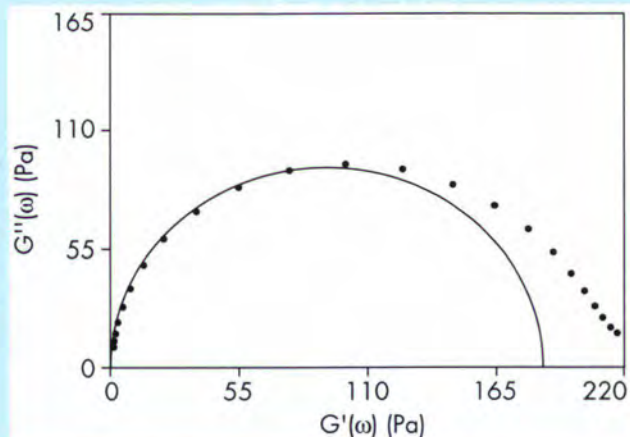

Fig. 5: Cole-Cole representation,  $\text{Cu}_2\text{-S}_8$  in methyl-cyclohexane ( $c=2.1\%$ wt). Full line is the semicircle fit ( $G_0 = 185\text{Pa}$ ,  $\tau = 0.65\text{s}$ ) for the monoexponential relaxation following the Maxwell model when only the points to the left of the maximum of  $G''$  are considered. This procedure emphasizes the high frequency departures for which the analysis is now under progress.

interactions of the aqueous "living polymers" emphasize the interest of this new class of binary materials. Furthermore, the very existence of molecular wires constituted by organometallic compounds in apolar organic media strongly encourage to search for some specific properties (electrical, magnetical, etc.).

This work results from a collaboration between "Laboratoire d'Ultrasons et de Dynamique des Fluides Complexes", Université Louis Pasteur, Strasbourg, France (M. Guenet) Département Recherche Fondamentale sur la Matière Condensée, CEN-Grenoble (P. Maldivi) and ILL.

### References

- [1] P. Terech in *Conference Proceedings Series, American Institute of Physics*, "The living cell in four dimensions", New-York, 226, 518 (1991).
- [2] P. G. De Gennes, in "*Scaling Concepts in Polymer Physics*", Cornell Press, Ithaca (1979).
- [3] P. Terech, *Colloid Polymer Sci.*, 269, 490 (1991).
- [4] J. Appell and G. Porte, *Europhysics Letters*, 12, 185 (1990)
- [5] M.E. Cates, *Macromolecules*, 20, 2289 (1987)
- [6] P. Maldivi, Thesis, Grenoble France (1989).
- [7] M. E. Cates and S. J. Candau, *J. Phys. Condens. Matter*, 2, 6869 (1990).
- [8] P. Terech, V. Schaffhauser, P. Maldivi and J.M. Guenet, *Europhysics Letters*, 17, 515 (1992)
- [9] V. Schaffhauser, Thesis, Strasbourg (in progress)

## INSTRUMENTATION



The new superconducting spin-echo magnets (see text in the 3-axis group section), installed for final testing on the host IN20 spectrometer. These optimized precession coils are expected to boost the energy resolution by several orders of magnitude.



Outside view of the new backscattering spectrometer IN10C, showing the mobile shielding with working platform and crane on top. Inside the instrument you can see one He-flight box and an analyser from its rear side. Left in the picture is the Doppler drive attached to the instrument.



Inside view of the new backscattering spectrometer IN10C with Yvon Blanc looking at the Si(111) analysers. The left eye of Yvon is mirrored by the mobile analyser, the right eye by one of the finished large angle analysers. One can also see the goniometers on which the analysers are mounted and the pneumatic automation needed to branch the analysers to the platform, by remote handling from outside.



Inside view of IN10C from the small-angle analyser side. Behind René Rebesco the sample table with goniometers and the graphite deflector-chopper, on the left hand side an analyser and a Helium flight box can be seen.

*Triple chopper for the TOF mode of the IN15 spectrometer.*

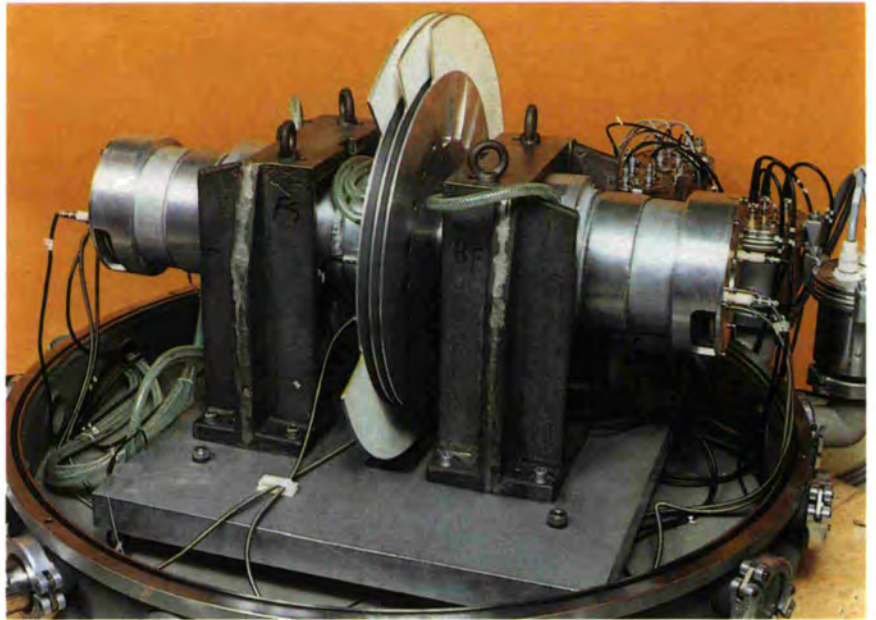
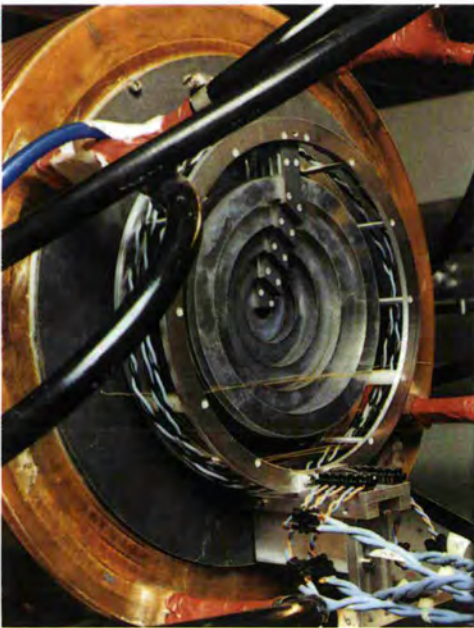

*Large Fresnel coil ( @ 20cm ) to be installed in front of the IN15 multidetector.*

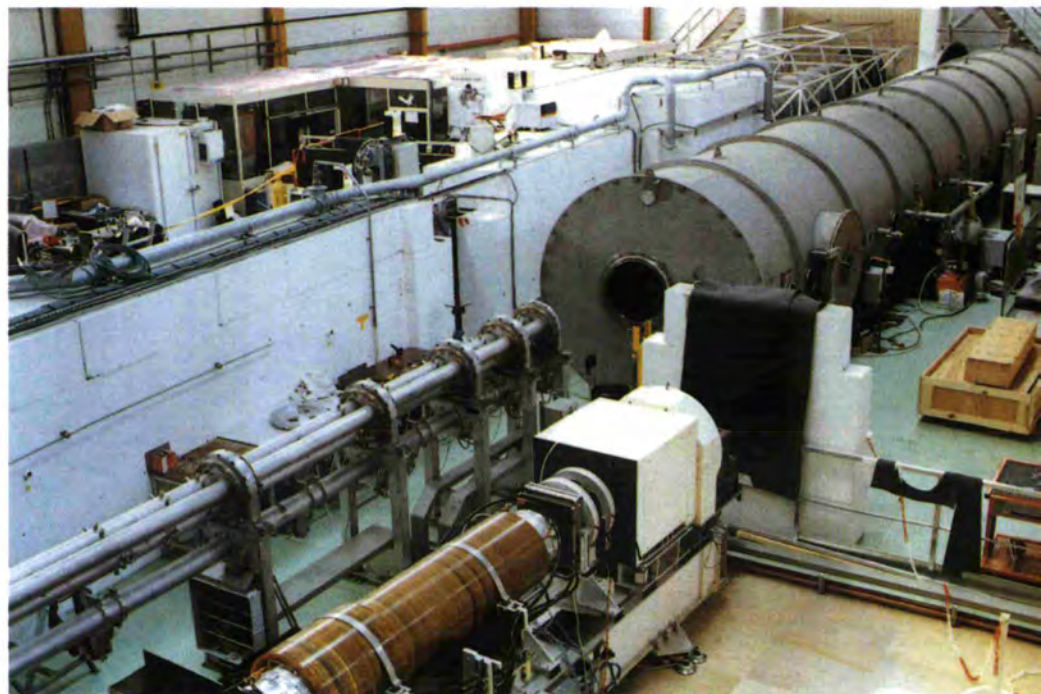

*The new low-Q SAS facility under construction on the cold guide H512.*

## INSTRUMENTATION

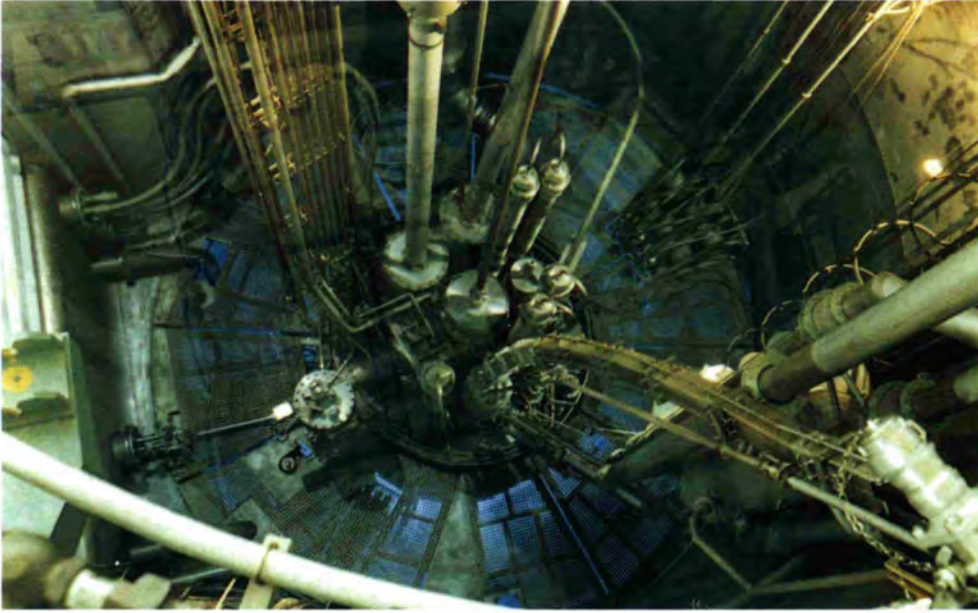

*View of the top of the heavy water vessel with the associated in-pile units.*

*The same view with all in-pile units removed.*



*Underwater removal of the beam-tube for the spectrometer PN2 (BILL).*

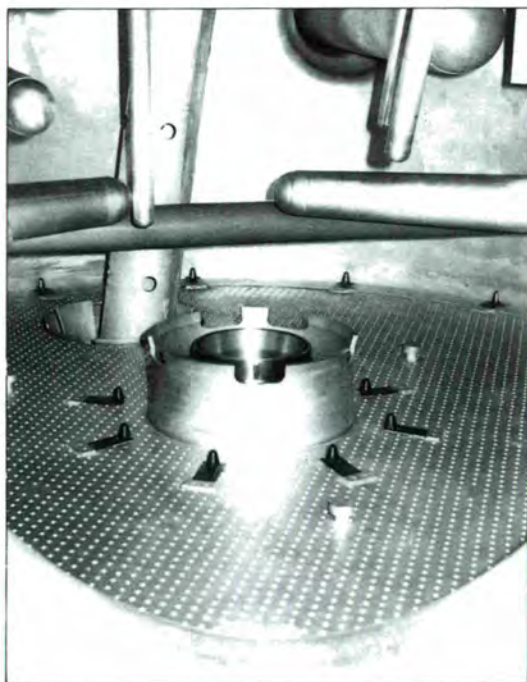

View inside the reflector tank seen from the beam-port H1-H2. The picture shows the baffle for smoothing the heavy water flow, the fuel element support, the BILL beam-tube as well as other beam-liners.

View of the mirror furnace installed inside the D19 diffractometer.

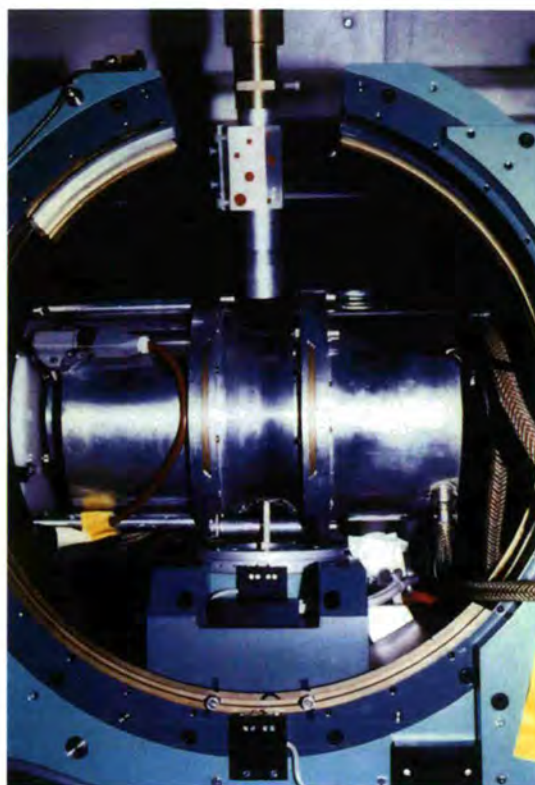

Fig. 3(college 9b box): Modelisation of the aggregate (molecular wire) for a  $\text{Cu}_2\text{-L4}$  derivative chosen instead of  $\text{Cu}_2\text{-S8}$  for sake of clarity. For  $\text{Cu}_2\text{-S8}$  the polar core is very much embedded in the ramified hydrophobic tails. Atoms : copper (green), oxygen (red), carbon (blue). Length scale : Van der Waals diameter of the carbon atom is  $1.57\text{\AA}$ .

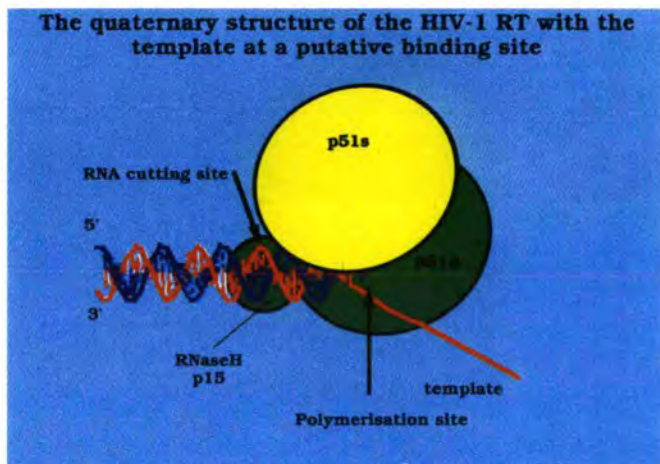

Fig. 3 (college 8): The tentative structure of the heterodimeric reverse transcriptase of HIV-1 as derived from neutron small-angle scattering with the template (viral RNA) docked at a putative binding site.

<i>– ADVANCED CRYOGENIC SERVICE</i>	<i>P. 90</i>
<i>– CENTRAL SERVICE</i>	<i>P. 90</i>
<i>– CHEMISTRY AND BIOLOGY LABORATORIES</i>	<i>P. 91</i>
<i>– BUILDING MAINTENANCE AND MODIFICATION SERVICE</i>	<i>P. 91</i>
<i>– INSTRUMENT GROUPS</i>	<i>P. 92</i>
<i>○ NUCLEAR AND FUNDAMENTAL PHYSICS</i>	<i>P. 92</i>
<i>○ THREE-AXIS SPECTROMETERS</i>	<i>P. 94</i>
<i>○ TIME-OF-FLIGHT, HIGH RESOLUTION AND DIFFUSE SCATTERING</i>	<i>P. 96 P. 96</i>
<i>○ DIFFRACTION INSTRUMENTS</i>	<i>P.101</i>
<i>○ SPECIAL INSTRUMENTS AND EXPERIMENTS</i>	<i>P.104</i>

The shutdown of the reactor since April 1991 has had a strong impact on the work to be carried out by the Instrument Operation Department (EDEX). The main activity, namely instrument operation, stopped completely and was replaced by instrument dismantling in the reactor hall and development work in the sample environment area and in other fields such as instrument construction. The latter was achieved by detachment of personnel to other Departments. Together with EDEX staff leaving the Institut the total number of staff in the Department was decreased by 14 people during this year. Subcontracting of work to outside companies has been replaced whenever possible by execution of this work by EDEX staff. The dismantling of the instruments and of the experimental sites in the reactor hall which started in October 1991 and which will be finished in March 1992, is being coordinated by EDEX and is executed in direct collaboration with the other technical departments and the Reactor Division. The removal of the equipment has been planned with the program MAC PROJECT and is carried out in three main phases:

- i) Removal of all ancillary experimental equipment.
- ii) Disconnection of all instrument services and removal of the instrument.
- iii) Dismantling of the instrument zone and of the primary protection.

At each stage records are made and photographs taken to assist in the reinstallation. A video film is being made of the important steps.

## Advanced Cryogenic Service

In the first three months of the year before the reactor shutdown the pool cryomagnets successfully completed 46 days of experiments and the dilution inserts were used for a total of 20 days on D20, D15 and IN3.

The gravity-insensitive dilution cryostat for 4-circle diffractometers has now been built, while work on the "Godfrin-Lauter" 5mK dilution refrigerator continues. The repairs required on the He<sup>3</sup> cryostat have been completed and the apparatus fully tested.

The new ILL Sample Environment Controller (ILLSEC) project is advancing steadily with tests being carried out on various possible designs and components, as well as keeping in close contact with electronics manufacturing companies in order to produce a fully industrialised instrument.

An intelligent programmable controller was purchased for the automation of the operation of the dilution refrigerator inserts. The installation and cabling of this instrument to the gas handling system has just been completed. The aim is to produce a system capable of automatically cooling down a sample from room temperature to below 0.1 Kelvin in the fastest and most

economical way possible, thus relieving the specialist technician of this routine task. This system will also serve as a test-bed for new ideas aimed at producing a more reliable automatic cryostat cold-valve.

The extended reactor shutdown has produced some special demands on the service: all sample environment apparatus (especially temperature controllers) has been recovered from the instruments and stored in a safe place; many requests for the loan of material, as well as technical assistance in its operation, have been made for experiments at other research centres.

## Central Service

The Central Service is responsible for the general organisation and maintenance for the experimental halls, assistance for the running instruments and provision of sample environment above 1.2 K. Major work carried on in 1991 includes:

- ▲ Dismantling of the instruments in the reactor hall.
- ▲ Participation in the project of modernisation of beam shutters.
- ▲ Installation and commissioning of the evaporator of the nuclear physics group.
- ▲ Improvements in the experimental preparation laboratory in the second neutron guide hall and in the  $\gamma$ -spectroscopy laboratory.
- ▲ Preparation and control of one transuranium experiment on IN14.
- ▲ Maintenance and improvements of orange cryostats, cryofurnaces, furnaces and high vacuum systems.
- ▲ Development of a high performance cryofurnace ( $77\text{ K} < T < 1000\text{ K}$ ) for the IN10 monochromator.
- ▲ Execution of 22 high pressure experiments.
- ▲ Calibration measurements of a 30 kbar clamp cell at the Siloe reactor.
- ▲ Evaluation of the safety margin of the CuBe gas cell by burst tests (burst pressure 9 kbar, maximum working pressure 5 kbar).
- ▲ Construction and commissioning of a TiZr cell working with a liquid as pressure transmitting medium ( $p_{\text{max}} = 12\text{ kbar}$ ).
- ▲ Help with the preparation of ILL experiments carried out at other reactor centres.
- ▲ 36 000 litres of liquid helium were used with a recovery rate of 94 %.

## **Chemistry and Biochemistry Laboratories**

Some improvements have been made in the Chemistry and Biochemistry Laboratories. The cold room has been equipped with working benches for onsite practical work. A falling ball viscometer and a tubular oven with large diameter have been bought.

## **Building Maintenance and Modifications Service**

The essential activities of the service are maintenance, repairs, improvements and construction, renovation, modification and equipment of site, buildings, technical installations (except the reactor), instruments (shielding) and zones around instruments.

In 1991, the main actions were:

- ▲ The dismantling of the experimental sites in the reactor hall.
- ▲ The installation of the ILL/ESRF telephone autocommutator.
- ▲ Modifications of the lifts.
- ▲ Studies for a new site entrance and a common medical service facility.
- ▲ Installation work in the second guide hall.

## Nuclear and Fundamental Physics

- PN1 Fission product separator LOHENGRIN on beam tube H9 (H.R. Faust, G. Fioni, I. Gartshore)
- PN2 Beta spectrometer BILL on the vertical beam tube V3 (S. Judge, U. Mayerhofer, H. Just)
- PN3 Three curved crystal spectrometers GAMS 1,2,3 and one flat crystal spectrometer GAMS 4 on the throughgoing beam tube H6-H7 (H. Börner, A. Williams, S. Ulbig, R. Oliver)
- PN4 Ge(Li) pair spectrometer on beam tube H7 (A. Williams, S. Ulbig, R. Oliver)
- PN7 Cold polarized beam at the end position of guide H14 (K. Schreckenbach, J. Last, R. Jubineaux)

### PN1 Fission product separator

At present, the ions of any chosen particular species arrive at the detector of the LOHENGRIN separator distributed over a 70 cm long parabolic arc according to their energy. By adding a new magnetic field region between the existing dispersive fields and the detector, as shown in Fig. 1, it should be possible to compensate the dispersion in energy and to focus all the ions of a given mass-over-charge ratio on a small spot. In some experiments, the use of a smaller detector area will considerably reduce the background, due to the additional discrimination arising from the orbit constraints set by the new field. In other cases, where the upper limit of the detector size has been a problem, energy focussing is predicted to give a sevenfold increase in the separated ion flux impinging the detector.

Early in 1991 a decision was taken to install an energy focussing magnet which is being provided by the group of Gönnerwein at the University of Tübingen. Beam optical calculations have proved the principle of energy focussing by dispersion matching and have defined the magnet characteristics shown in Table 1. The technical design of the magnet has now been completed; it has been ordered and delivery is expected at the end of 1991.

As part of the project, components at the exit slit of LOHENGRIN have to be redesigned. Work on a new vacuum chamber and diaphragms has begun. In parallel, a new ionisation chamber is being developed to take full advantage of the focussing. Casemate modifications including a new concrete plinth and steel supports as shown in Fig. 2, are needed to accommodate the 6 ton magnet, and to hold it in the correct position and orientation at the exit slit. It is planned to complete the installation by mid 1992.

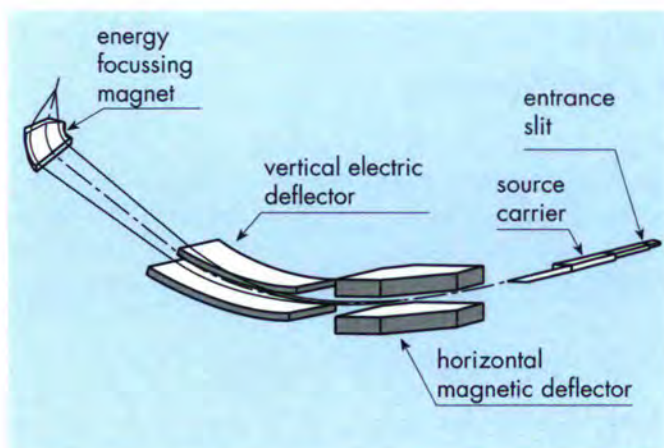

Fig. 1: The position of the new energy focussing magnet in relation to the other main components of the mass separator LOHENGRIN.

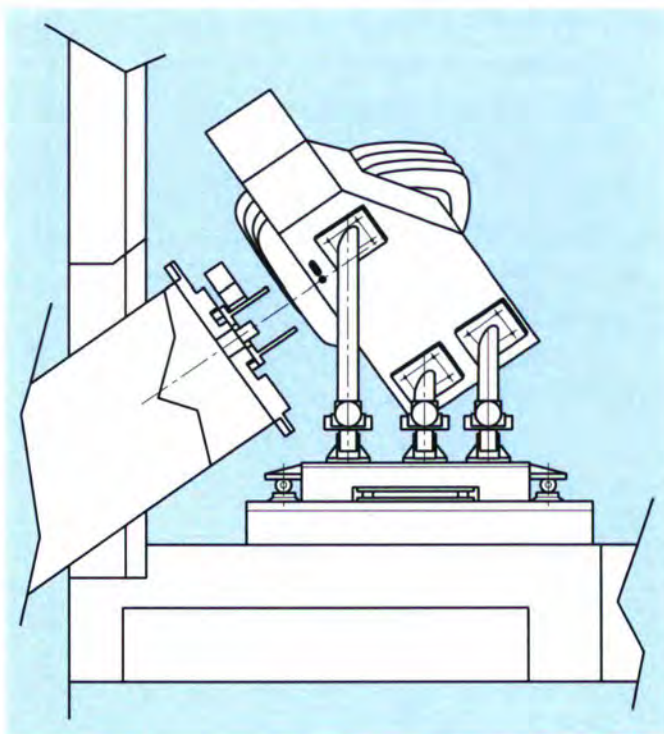

Fig. 2: Mounting of the new magnet at the exit slit of LOHENGRIN.

### PN2 Electron spectrometer

The experiment using the BILL electron spectrometer to search for a heavy neutrino in the beta decay of  $^{177}\text{Lu}$  produced a negative result at more than 80% confidence compared with what might have been expected from some recent results elsewhere using silicon detectors. The ILL experiment has excited much interest, providing a strong motivation to see whether even better experiments of this type could be carried out using BILL. The ILL isotope was created in the target by neutron capture while the reactor was

$B \times \rho$	0.9 T x m
Angle of deflection	65°
Radius of deflection	600 mm
$B_{\max}$	1.5 T
Gap between the pole pieces	50 mm
Radial homogeneity	$<10^{-3}$ over $\pm 200$ mm at the entrance
	over $\pm 75$ mm - 120 mm at the exit
Profile of the pole pieces	Approx. Rogowski
Cross section of the coils	150x76 mm <sup>2</sup>
Electric resistance of the coils	0.0764 $\Omega$
Max. electric power	17.5 kW
Cooling water flux ( $\Delta T = 20^\circ \text{C}$ ) at 3 bar	12.5 l/min
Total weight ca.	6125 kg

Table 1: Technical characteristics of the LOHENGRIN energy focussing magnet.

running. The careful measurements of the shape of the spectrum near the end-point were then made during the two weeks following the end of the reactor cycle. One of the problems of the experiment was caused by the background beta particles coming from activation of the walls of the beam tube deep inside the reactor and the fact that this background evolves considerably with time after the end of a reactor cycle. It was concluded that better heavy-neutrino-search experiments could be performed by removing BILL from the reactor and using it with a radioactive source. The repair of the ILL reactor is an excellent opportunity for implementing this experiment. Accordingly, BILL has been moved to the PN7 area where further experiments to search for a heavy neutrino are planned using beta sources produced by neutron capture in the neighbouring SILOE reactor. Previously, BILL had a first magnet using the neutron capture foil close to the reactor core (about 10 m away) as object and created an image close to the second or main analysing magnet. The first magnet has been removed and a source chamber has to be constructed to put the radioactive source where the image from the first magnet used to be. The new evaporator has been delivered which can be used to prepare sources on thin strips.

The idea of moving BILL has also prompted studies of projects which could be achieved if the main magnet was used for experiments with in-beam capture sources at an external beam position (see Fig. 3). The conclusion is that a variety of new projects are feasible where fluxes exceed  $10^{10} \text{ cm}^{-2} \text{ s}^{-1}$ . Depending on uncertainties in available fluxes and background the sensitivity in the new position has been estimated to be between 0.08 and 1.0 times the sensitivity, using the in-pile source. Since the nuclear decay processes under study would then take place at an accessible

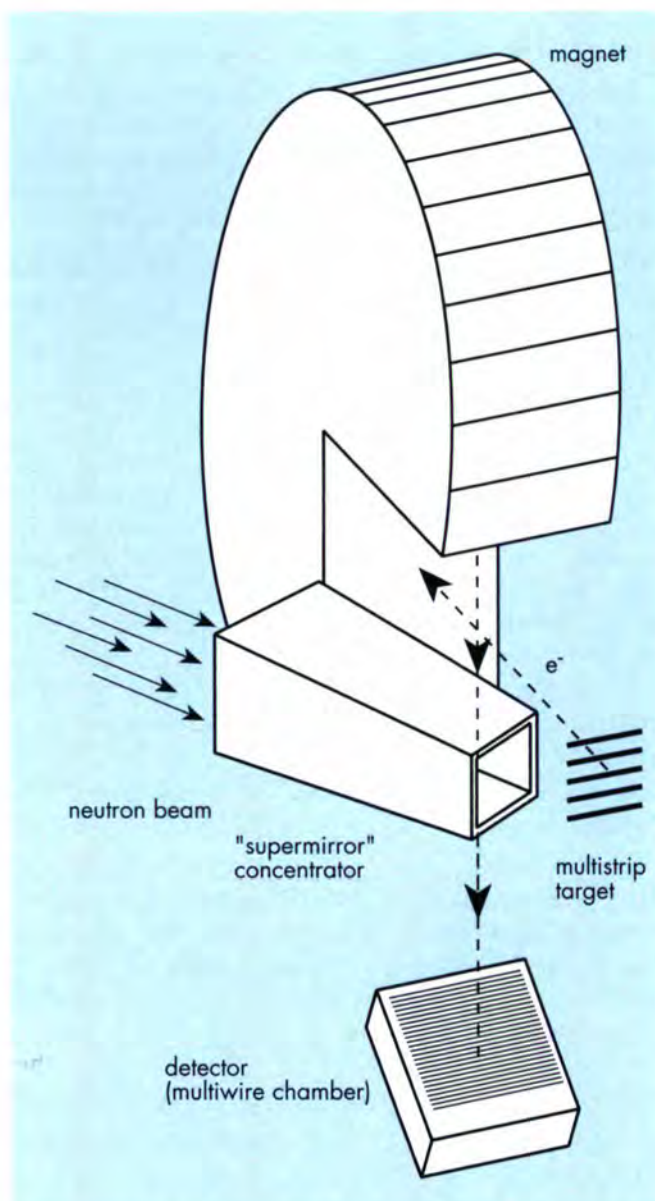

Fig. 3: The main BILL magnet as it is proposed to use it with the neutron target/electron source in an external neutron beam. The target would be divided into strips each held at a different electric potential. This allows the target size to be increased without spoiling the resolution for the electron energy measurement and thus helps to compensate for the lower neutron flux compared with that previously available for in-pile targets.

location, exciting new opportunities would open up, including coincidence measurements. In particular, additional spectroscopic possibilities are being explored using the BILL-Magnet in conjunction with a state-of-the-art gamma-ray coincidence system.

### PN3,4 Gamma ray spectrometers

New interferometers to control the crystal angles for the GAMS2,3 spectrometers have been designed this year and should be built in 1992. They involve the new principles already developed and tested on GAMS4 where non-

linearity errors in the interferometer fringe phase determination have been reduced by a factor of 7. The results for phase errors in recent test measurements on the system for GAMS4 are shown in Fig. 4. Another idea, under examination, is the use of glass ceramics for the key interferometer parts to exploit their very low thermal expansion coefficients to gain thermal stability.

On the electron-positron pair production spectrometer the electronics has been upgraded for simultaneous operation in the Compton-scattering suppression mode.

### PN7 Cold polarised beam facility

Several lengths of 5 cm x 3 cm guide, amounting to a total length of about 5 m have been delivered for the PN7 set-up. These guides will be used to conduct the neutron beam from the polariser to the experimental area. In many experiments this distance needs to be large to reduce backgrounds. They are constructed from borated glass and in order to have a high critical angle/wavelength ratio; and, to be strictly non-ferromagnetic, the reflecting surfaces are coated with  $^{65}\text{Cu}$ . The guides were manufactured by Dr. E. Steichele of T.U. Munich. Their use is expected to provide a factor of 2 flux gain. Unfortunately the reactor was stopped before the first test measurements could be completed.

As a first step to modernise the data taking at this facility, the CAMAC has been interfaced to an IBM PC compatible computer. It is planned to use a fast PC as the front-end processor linked to a larger machine via Ethernet. Data storage and analysis software will be based on CERN standards.

Coordinator: M. Pendlebury

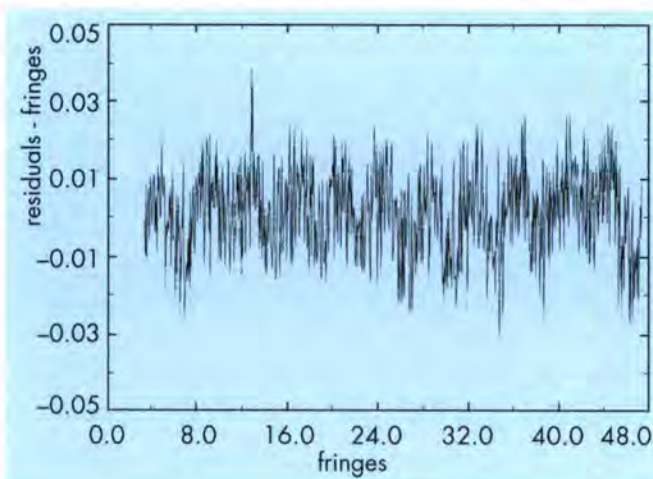

Fig. 4: Data from a test of the new interferometer controlling the angular position of the analysing crystal on GAMS4. This sweep over 48 interferometer fringes shows a barely perceptible non-linearity of 0.01 fringe which, in turn, corresponds to a non-linearity of 0.0004 arc second for the crystal angle. This is a sevenfold improvement compared with the previous control system.

## Three-Axis Spectrometers

- IN1, INFB 3-axis and Be-filter spectrometer on the hot source beam tube H8 (H.J. Lauter, B. Dorner and P. Palleau).
- IN8 3-axis spectrometer on the thermal beam-tube H10 (J.L. Martinez, J. Bossy and T. Hornsby).
- IN12 3-axis spectrometer on the cold guide H142 (B. Fak, S. Bramwell and D. Puschner).
- IN14 3-axis spectrometer on the cold guide H53 on the horizontal cold source (R. Currat and A. Brochier).
- IN20 3-axis spectrometer for neutron polarization analysis and spin-echo option on the thermal beam-tube H13 ( M. Alba, J. Kulda, C.M.E. Zeyen and A. Dorn).

### IN1 and INFB Hot source three-axis and Be-filter spectrometer (H8)

The instrument IN1 operated reliably over the short scheduled period. The reactor shutdown will be used to modernize part of the electronics; to install a new mechanical drive controlling the monochromator curvature; to construct an insulated cabin for a more quiet on-line data treatment during experiments (to be shared with INFB and D4). It is also hoped that, by the reactor start-up, the beryllium monochromator will be available and can be mounted together with the existing three copper crystals.

The Be-filter option (INFB) is presently used in combination with the Cu(200) or Cu(220) monochromator (with programmable interchange between the two crystals), in order to match the 5 meV resolution of the filter itself. The Be-graphite combination filter, with a resolution of better than 2 meV, normally requires the use of the Cu(331) monochromator crystal. No major modifications are foreseen during the reactor stop.

### IN8 Three-axis spectrometer on the thermal beam-tube H10

The instrument IN8 was operational during the first trimester of the year. New, encoded and computer controlled diaphragms were installed before and after the sample position (diaphragms D2 and D3). The first diaphragm in the beam (D1), was equipped with enriched  $^6\text{LiF}$  absorbing material, in order to reduce the  $\gamma$ -background in the experimental area. At the end of the year the instrument was partly dismantled to provide space in the reactor hall. During the shutdown, all shaft encoders and associated electronics will be modernized. The switch from CAMAC to VME is also envisaged, if the corresponding budget is made available.

**IN12 Three-axis spectrometer on the cold guide H142**

IN12 operated reliably until the reactor shutdown. A complete optical realignment of the spectrometer, including a reparation of the  $\alpha_2$  collimator support, improved the flux by 25% and completely eliminated earlier alignment problems. A series of calibration and test measurements have been performed to characterize the different components, such as monochromator focussing mechanism, Be-filter, supermirror bender, and Heusler analyzer. The flux as a function of incident wave vector, the higher-order contamination, the energy resolution, and the performance in polarized mode have been determined. The equipment for polarization analysis has been improved, including a new spin flipper, new guide fields, and an upgrade of the six computer-controlled power supplies. The range of the spectrometer for small-angle scattering experiments has been extended. The fast neutron background problem on D11 when uranium samples are used on IN12 has been investigated. The resulting new guide-lines are that only samples with less than 0.1 g natural U are accepted on IN12. For larger samples (or for samples containing more  $^{235}\text{U}$ ) IN14 should be used. A study has been initiated to improve the flexibility and reproducibility of the spectrometer in polarized mode and to make collimator interchanges easier and more user-friendly.

**IN14 Three-axis spectrometer on the horizontal cold source (H53 guide)**

IN14 was fully operational during the scheduled period. A complete description of the instrument's characteristics and performance, in both polarized and unpolarized modes, is available in report form (91FA09T). During the reactor shutdown the following instrument developments are planned: a modification of the connection between the monochromator drum and the sample table, to allow for a more compact geometry; the production of a second supermirror bender, optimized for the low energy range (2 to 5 meV); additional tests on the variable-wavelength pyrolytic-graphite filter; a design study and implementation of a doubly-curved PG monochromator. It is hoped that the instrument itself will not have to be dismantled and may thus be available for software and electronic tests during part of the shutdown period.

**IN20 Three-axis spectrometer with polarization analysis on the thermal beam H13**

IN20 performed without problems during the scheduled reactor period. The instrument is normally used in the polarized mode in conjunction with the vertical-field 6T cryomagnet. Most of the technical work on the instrument was connected with the cryomagnet's maintenance and with the implementation of the spin-echo option (see next Section). In this latter context, two instrument modifications are required: the extension of the "tanzboden" floor in order

to accommodate the 1.5 m long spin-echo magnets, and an increase in on-line computing capacity. The first modification was completed in time for the final magnet tests (see picture on page 84). The second one involves the replacement of the instrument's PDP11 by a  $\mu\text{VAX}$  needed in order to handle the complex spin-echo software. The  $\mu\text{VAX}$  has been ordered and a new, VAX-compatible, version of the TAS software will soon be available.

**TASSE on IN20 with OFS superconducting precession coils**

The equipment for this first full-fledged thermal-neutron Spin-Echo Three-Axis Spectrometer (TASSE), based on the experience with the early Test Set-up on D10 and on the new Optimal Field Shape (OFS) concept, is now completed.

The two superconducting (0.2 mm NbTi multi-filament wire) Larmor precession cylinder magnets are composed of thirty superposed coaxial coils of different lengths (ranging from 0.2 to 1.4 meters) in order to produce the OFS determined by variational calculation. The maximum line integral is 1.5 Tesla x meter giving more than  $10^4$  precessions for thermal neutrons. The very small coil diameter of 8 cm guarantees very small fringe fields.

The OFS is the best cylinder magnetic axial field shape for NSE. It is the analytical solution of the variational problem  $\int^L |B| dl = \text{constant}$  (Zeyen 1988). Compared to the presently existing NSE solenoid magnets (IN11, IN15, LLB, KUR, KFA) these OFS magnets have better homogeneity, they can compensate pathlength effects and they are shorter and have much reduced diameters. For comparable line integrals they are therefore cheaper, consume less power and have less fringe fields. The latter point is crucial for TAS experiments where the sample scattering angle is variable.

The OFS yields close to zero field and zero gradient at the flipper positions. To enable operation at very low precession fields a special superconducting guide field coil has been added in such a way as to furnish zero net precession.

The coils are cooled with a three-stage refrigerator system which operates fully automatically. No cryogenic liquids are required. The refrigerators are used to cool the magnets to 4 K, to liquefy 10 liters of liquid helium into the coil reservoir from a gas bottle, and to condense the evaporating helium back into the bath in a continuous way. The thermal shield of the coil is also cooled by the refrigerator's first stage via a closed nitrogen loop. A warm axial bore for the neutron beam is provided.

The coils also feature line integral correction devices for the path length variations arising from the relatively large angular divergence to be used for better luminosity.

Furthermore special gradient coils (Zeyen, Rem 1991) have been designed to enable spin-echo focussing to dispersive elementary excitations in order to determine their

lifetimes. These gradient coils also allow a non-linear matching of the dispersion surface (in one dimension for a start).

**References:**

B. FAK, M. ALBA, R. CURRAT and A. BROCHIER,  
 " Flux and Calibration Measurements on IN14",  
 ILL Report 91FA09T

ZEYEN C.M.E. "Probing structural dynamics by very high resolution neutron three-axis spin-echo spectroscopy",  
 in 'THE TIME DOMAIN IN SURFACE AND STRUCTURAL DYNAMICS', G.J.LONG & al. EDS.  
 (KLUWER ACAD. PUBL.1988), PP. 213-232

ZEYEN C.M.E. and REM P.C., "Optimal Larmor precession field shapes : Application to neutron spin-echo spectrometry", Submitted to J. Phys. E

Coordinator : R. Currat

## Time-of-Flight, High Resolution and Diffuse Scattering

- IN4      Time-of-flight spectrometer on the thermal tube H12 (A. Murani, H. Mutka, T. Haering (technician))
- IN4C    New TOF spectrometer with a Brillouin option (project) (H. Mutka, T. Haering (technician))
- IN5      Multichopper TOF spectrometer on the cold guide H16 (G. Kearley, F. Rieutord, H. Blank, S. Jenkins (technician))
- IN6      Focussing TOF spectrometer on the cold guide H15 (A.J. Dianoux, R. White, S. Jenkins (technician), Y. Blanc (technician))
- IN10    Upgraded backscattering spectrometer on the cold guide H15 (J. Cook, P. Joubert (technician))
- IN10C   New backscattering spectrometer on the cold guide H53 (project) (B. Frick, J. L. Coquin, Y. Blanc (technician))
- IN11    Spin-echo spectrometer on the cold guide H141 (B. Farago, J.F. Legrand, E. Thaveron (technician))
- IN13    Backscattering spectrometer for short wavelengths on the thermal guide H24 (W. Petry, J. Williams, J.F. Barthélémy (technician), H.J. Heuer (technician))
- IN15    High-resolution spin-echo spectrometer for long wavelengths on the cold guide H511 (project) (C. Lartigue, F. Mezei, D. Richter, F. Douchin, J.F. Barthélémy (technician), H.J. Heuer (technician))
- D7      Diffuse scattering instrument with polarization analysis on cold guide H15 (O. Schärpf, R. Rebesco (technician))
- D11    Small-angle scattering diffractometer on the cold guide H15 (P. Lindner, P. Timmins, R. May, R. Baker (technician))
- D17    Low-Q, low-resolution diffractometer on the cold guide H17 (R. May, P. Terech, M. Cruz (technician), R. Gay (technician))
- D22    New low-Q diffractometer on the cold guide H512 (project) (R. May, M. Thomas, R. Gay (technician))  
 Group Engineer: F. Douchin

### IN4 TOF spectrometer on the thermal tube H12

The instrument performed extremely well during the short period of operation at the beginning of the year Jan-

March 91, and all scheduled experiments for that period were completed. Since the beam port H12 on which IN4 is situated was required for examination at the structural aspects and radioactivity levels, by the reactor department, the instrument was one of the first to be demounted during July/August. It has been decided that the present spectrometer will not be reinstalled when the reactor is ready to begin operations again, but it is hoped that the new spectrometer IN4C will be available for use soon afterwards.

#### **IN4C New TOF spectrometer with a Brillouin option**

The technical specification of the IN4C TOF has been compiled with the collaboration of DIM. Extensive finite element modelization of the choppers, the mechanical resistance of which is a decisive factor in the optimization of the beam optics, has been carried out. The results have shown that a beam size of  $140 \times 120 \text{ mm}^2$  can be achieved at a rotation speed of 16600 rpm, quite adequate for the background choppers. The team in charge of the project now includes two draftsmen and ensures rapid progress of the study which is concentrated on the primary spectrometer. A test scale prototype for a small angle detector is under construction and will provide the final specifications for the detector around April 92.

Tests on the double monochromator for the Brillouin option of IN4C were carried out in a concentrated effort in collaboration with EDEX, the monochromator group and the electronics group. Using oriented Be-ingots of an effective size of about  $2 \text{ cm}^2$ , a highly collimated beam ( $\lambda = 1 \text{ \AA}$ ) with an intensity of  $7 \times 10^3 \text{ n/cm}^2\text{s}$  was obtained. Time resolution remains rather poor because of a too long chopper-to-sample distance but the results were globally encouraging. The Monte-Carlo simulation of the performance of this instrument now includes the required converging collimator and the calculation of the Q-resolution.

#### **IN5 Multichopper TOF spectrometer on the cold guide H16**

The most important modification of IN5 has been the permanent installation of a conical evacuated tube in the secondary flight path to eliminate gas scattering from the direct, or near direct beam. This tube leads directly to a D11-type multidetector which is married to the IN5 counting system. A wide variety of groupings of the multidetector cells is available by software.

In order to reduce cross-talk between detectors at short wavelengths, and to generally reduce the background, gadolinium-oxide coated baffles have also been installed to segment the secondary flight-path. Upper and lower baffles have also been installed to prevent secondary scattering from any part of the "gas-tight" bag. We look forward to testing these improvements.

A very powerful data inspection and image-processing package was written and installed by D. Richard. This three

dimensional colour display utility is sufficiently rapid to allow several  $S(Q,\omega)$  surfaces to be compared and manipulated together.

#### **IN6 Focussing TOF spectrometer on the cold guide H15**

In the short available period, January - March 1991, the instrument performed satisfactorily with 14 experiments carried out. Some elusive problems were encountered (once or twice a week) with the new VME data acquisition system, but seemed to be cured before the reactor shutdown.

For the remaining part of the year, most of the activity around IN6 has been the development of the VME chopper control which proved more difficult than anticipated. This work carried out by the Electronics Service is a first step for the VME chopper control of IN4C and IN5.

#### **IN10 Upgraded backscattering spectrometer on the cold guide H15**

During the limited period of reactor operation this year, IN10 operated with no technical hitches. In cycle 905(b) (7 Jan - 1 Feb), three scheduled experiments were performed of which two days of measuring time were lost due to an unscheduled reactor shut-down. These days were recovered by another measuring team due to the two day extension of the cycle. In cycle 911 (12 Feb - 30 March), six scheduled experiments were performed with no losses of measuring time.

Cycle 911 included the successful completion of the first two scheduled experiments using the monochromator heating option, IN10B. These first results are very encouraging and are summarised in ref. /1/. For example, Fig. 1 shows a tunnelling multiplet produced by the rotation of quasi-free methyl groups in  $\gamma$ -picoline quenched rapidly to 1.5 K. This spectrum was obtained using the IN10B configuration by heating a NaCl(200) monochromator from about 80 K to 550 K. The energy resolution of around  $1.4 \mu\text{eV}$  (FWHM) was sufficient to resolve a finer structure initially sublying the main peaks (Fig. 1(a)). A further measurement of this same spectrum after 3 days revealed a change in the relative intensities of the main peaks and a decay of the finer structure. These observations are consistent with a system of coupled methyl groups which undergo spin conversion with time. More details will be given in a later paper. Although the exploitation of IN10B has been curtailed by the prolonged shutdown of the reactor, we now have the time to refine its operation. In particular, a program for improved automation has been launched. This will involve abandoning the CAMAC and passing the control of all motor axes in VME. This will also mean that the "Precilec" coders (for which future maintenance has become uncertain) will be exchanged for "Moore-Reed" or "Synchro" coders. This conversion will have the additional advantage of compatibility with IN10C. Further experience will be gained from tests of IN10C early in 1992. An improved cryofurnace, providing a temperature range

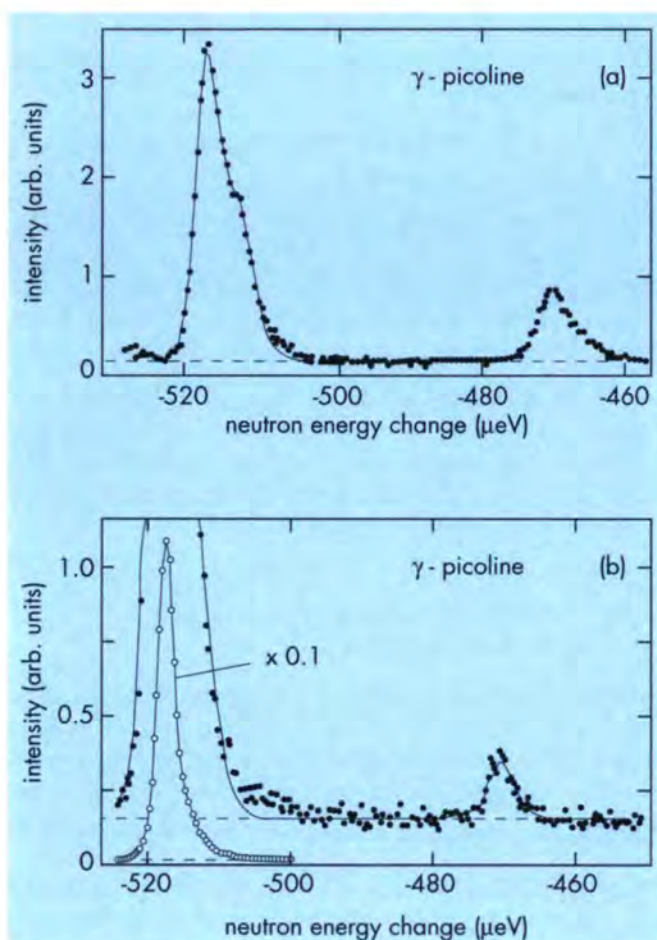

Fig. 1 : The downscattering inelastic peaks of tunneling quasi-free methyl groups in  $\gamma$ -picoline measured using thermal expansion of a Na Cl(200) monochromator. The spectrum obtained immediately after quenching of the sample to 1.5K (a) is distinctly different from that obtained from the sample kept at this temperature for 3 days (b). The continuous lines represent a fit of a scattering law consisting of a sum of four Lorentzians convoluted with the Na Cl(200)-Na Cl(200) resolution function.

$80 < T(K) < 1000$ , is also envisaged for IN10B. The design of this cryofurnace has virtually been finalised. During the summer, tests were carried out on an automated valve system for control of the coolant (N<sub>2</sub>) flow in the above-mentioned cryofurnace. This system is destined to be adopted in place of the existing manual regulation and will greatly contribute to the 'user-friendliness' of IN10B. Test measurements have also been carried out on the monochromator crystals supplied to date for IN10B. The techniques which have been used include neutron backscattering and X-ray Laue measurements (Munich). Rocking curves have also been obtained by  $\gamma$  diffractometry (ILL). The combined results clearly show that the quality of certain crystals is unsatisfactory. The replacement of the defective crystals is currently being negotiated with the suppliers.

Other instrumental improvements during 1991 have included the redesign of the nitrogen loop so as to

incorporate a sample well which may be filled with an exchange gas. This change has been made in order to improve the temperature homogeneity of samples, particularly in the upper temperature range. Computer simulation has been used to design an optimised cylindrical vanadium standard for IN10 and IN10C for which the fraction of multiple scattering is well-determined. These samples have been constructed using high purity vanadium sheet. Computer simulation is also being used to predict the resolution function of IN10. These studies are of particular interest for IN10B where access to the elastic peak is not always possible.

### IN10C New backscattering spectrometer on the cold guide H53

All major technical components of the new backscattering instrument IN10C were finished and mounted in 1991. The instrument is now awaiting the reactor startup in order to test simultaneously the energy resolution and the neutron flux.

At the beginning of 1991 the mobile platform was mounted, together with the mobile analyser, the sample table with goniometer, detector and graphite deflector-chopper. The second set of the spherical analyser supports, including adjustment mechanics for the small angle rings, was supplied in spring by the KFA-Jülich.

Two complete sets of analysers and goniometer supports are now available (see photo on page 84). The goniometers are mounted on air pads, and allow us to connect the analysers reproducibly by means of pneumatic equipment to the mobile platform.

A major progress has been the mounting of the shielding in July. The shielding (see photo on page 84) represents an iron-aluminium structure covered by 10 cm polyethylene, B<sub>4</sub>C and Cd coating on the inside with a total weight of ~ 2 tons. The three large double doors permit the changing of the analysers and the three Helium flight boxes, which fill completely the inner part of the shielding leaving a distance of roughly 25 cm to the sample centre. The whole assembly including the Doppler machine moves smoothly on air pads between scattering angles of  $30^\circ \leq 2\theta \leq 157^\circ$ . The choppers (background chopper and graphite deflector-chopper) are now spinning smoothly as well and their phasing is currently under test. Concerning the sample environment a cryofurnace has just been finished and a collimator, which may be introduced optionally between the He-flight boxes and the cryostat, is being studied and will be built at the beginning of next year. Concerning the glueing of the analyser crystals three spherical large angle supports are already finished. On each plate about 60000 Si single crystals with (111) surface orientation, a size of  $4 \times 4 \text{ mm}^2$  and a thickness of 0.4 mm are glued. The glueing was interrupted in July due to the suspicion that the single crystals might be deformed, as deduced from the optical image of a small light source and from  $\gamma$ -ray investigations.

Only neutron measurements, however, can give the answer if this effect might spoil the experimental energy resolution. Currently attempts are being made to test the analysers elsewhere, producing a divergent neutron beam.

#### **IN11 Neutron Spin-Echo on the cold guide H141**

During this year's short working period the instrument was operating smoothly. A couple of improvements are proposed to be done during the shut-down of the HFR :

a) Imperfections of the winding of the main precession coils were detected during the highest resolution experiments. The example of IN15 shows that good precision winding can now be achieved by industrial companies. The current connections of the coils can also be improved to minimize the disturbing stray-fields. It is proposed that the double three coil setting should be replaced by a two-fold (one long+one short) single setting.

b) A closed circuit cooling system is planned

c) It is likely that the present PDP-11 computer will be changed. Depending on the future policy (UNIX versus VMS) this might have consequences on the instrument electronics. The IN11C magnet will be delivered before the end of the year. Engineering for the necessary modification of the present IN11 are starting now.

#### **IN13 Backscattering spectrometer for short wavelengths on the thermal guide H24**

The reactor shutdown has immediately been used to perform major renewals of the spectrometer: the PDP11 instrument computer was changed for a standard  $\mu$ -Vax. On that occasion a new version of the acquisition programme has been installed. Now the user interface is identical to that of other instruments such as IN4, IN5, IN6 and all the data evaluation software is also installed on the instrument computer. Important for the future reliability is the complete replacement of the positioning and reading electronics of the most important motors of IN13.

The long reactor shutdown will be used to test additional configurations of IN13 in order to open IN13 to new domains in high resolution spectroscopy.

– Replacing the  $\text{CaF}_2(422)$  monochromator by a  $\text{KCl}(440)$  monochromator the energy range of currently - 125 to 320  $\mu\text{eV}$  can be increased to a range of - 250  $\mu\text{eV}$  to + 690  $\mu\text{eV}$  with otherwise unchanged parameters of IN13.

– Using sets of different monochromator crystals (other than  $\text{CaF}_2(422)$ ) the energy transfer range can be extended largely above 1 meV with an unchanged energy resolution of  $\sim 10 \mu\text{eV}$  and unchanged Q range 0.3 - 5.5  $\text{\AA}^{-1}$ .

– It may be interesting to work at a longer wavelength, namely  $\lambda = 3.3 \text{\AA}$ , in order to decrease the general phonon-related background of IN13. Naturally this goes on the expense of the Q-range. A possible analyser crystal for this wavelength is  $\text{Si}(311)$ .

#### **IN15 High Resolution Spin-Echo Spectrometer for long wavelengths on the cold guide H511**

The year started with a few improvements before performing new measurements. Long tubes for helium gas were installed on the neutron path to reduce neutron losses by air absorption. The program MAD for running the experiment from the VAX has been installed: the software for the control of the different parts of the instrument and for multidetector data acquisition has been developed under OS9 and VMS systems. Only very few neutron tests were carried out before the reactor shutdown. Moreover, the beam polarization was rather poor: the transmission polarizer was not yet installed; the supermirrors were just ready at the beginning of April but could not be tested.

For the focussing option, the prototype toroidal mirror ( $\approx 10\text{m}$  focal length and 50 cm length ) with a guaranteed  $\mu$ -roughness of less than 3 $\text{\AA}$  pp will be delivered by Zeiss by the end of November. The idea was to test it under real conditions on IN15 before ordering the final 4m long mirror. This is no longer possible. We thank the LLB-Saclay for giving us the possibility of performing this measurement at the beginning of next year. The whole experiment is being prepared at the ILL before being installed in Saclay (small angle scattering with 15 $\text{\AA}$  neutron wavelength).

For the time-of-flight option, a set of 3 choppers (54 cm diameter) and a "big" chopper (80 cm diameter) were mechanically tested at the ILL. The electronics has been delivered by KFA-ZEL from Jülich in October: the choppers and the ramps of current in the flipper coils can be locally driven and controlled by a MacIntosh. The system is currently under extensive tests at the ILL. However, the present set of motor and power supply is not sufficient for a smooth drive of the "big" chopper (same problem as for the velocity selector); it will be reexamined in Jülich. The software for the remote control has to be developed (OS9 system+Vax) by a collaboration between the ILL and the KFA-ZEL group of Jülich.

#### **D7 Diffuse-scattering instrument with polarization analysis on cold guide H15**

Until now, only every second of the 64 detectors of D7 is equipped with a polarization analyser. Last year, it was planned to try at least on one detector bank whether it would be possible to use also the rest of the detectors for polarisation analysis by a modified analyzer arrangement requiring no additional mirrors. Unfortunately the HFR was shutdown when all parts were ready for testing.

Progress was also made in publishing clear descriptions of experimental methods covered by D7, e.g. new scientific fields such as large angle-scattering (LANS) from polymers. Relying only on small angle-scattering (SANS) results may often not be conclusive. In the small-angle region, all units scatter in phase, i.e. the strong coherent scattering is easily distinguishable from the background. Two other methods

permit the detection of coherent scattering: reflectivity experiments and polarization analysis. In LANS experiments the only useful methods are polarization analysis which was widely applied when studying polymer structures, and may be proton polarization.

Furthermore, D7 yields quantitative information for magnetic scattering, e.g. for magnetism in high  $T_c$  superconductors where intense beams are required in order to observe possible magnetic scattering.

**D11 Small-angle scattering diffractometer on the cold guide H15**

A new collimation system was installed on D11 in February 1991. The system works on the same principle of moveable guide sections as the previous system but is much more flexible. Fig. 2 shows the collimation distances which can be selected. The movement of the guides is fully automated and controlled by the instrument computer. The housing of the collimation system is made of aluminium in order to provide a non-magnetic environment for IN11. The new collimation system (see Fig. 2) and already existing diaphragms, as well as the unchanged 20 m collimation section immediately after the velocity selector, were completely realigned leading to a small increase in flux at the sample particularly at short collimation distances. There was approximately one month of routine running after installation of the collimation system until the reactor shutdown, during which time the system operated without problem.

The new velocity selector, designed at ILL, was delivered and tested in the "hall d'essai" at the beginning of the year. The lightweight selector, giving a wavelength spread of 10 % (FWHM), has a length of only 40 cm and operates in vacuum. A piece of fixed guide will be inserted in the flight path between the guide H16 and the entry to the velocity selector resulting in a significant gain in flux. The selector was installed at D11 in April 1991 but has not yet been tested with neutrons due to the HFR shut-down.

A new sample table has been purchased which will allow a particular sample environment to be prepared and aligned before the experiment and then be wheeled into position thus saving valuable beam-time.

At the beginning of the year, a new technician, Andreas Polsak, coming from the University of Stuttgart, has joined us. He has been using the shut-down for various improvements of the instrument.

**D17 Low-Q, low-resolution diffractometer on the cold guide H17**

Manuel Cruz, the technician of D17, who had provided an excellent service to innumerable users of the instrument since 1978, left the ILL for an anticipated retirement at the end of 1991. We shall miss his human and technical competence and wish him all the best for his future plans. During the last months he helped the D11 technician to get

acquainted with all details of the instrument.

During the short reactor period in 1991 the instrument was operating without any major problems. The cabin has been renewed in January 1991 and the space available to visitors has been enlarged. The detector rotation has been revised in order to improve the precision for  $\omega$ -scans: the "Tanzboden" at the instrument has been completely replaced by a new marble floor, the air pads, the support with the bearing and the encoder for the detector rotation have been cleaned and refixed and the PID parameters for the computer controlled rotational movement have been readjusted so that  $\omega$ -scans are now possible again with a precision of  $\pm 0.03$  degree.

In the framework of the ILL Users' meeting on the second modernization programme in October 1991 in Uriage a possible "descheduling" of D17 for budgetary reasons was discussed. Strong support from the user community, however, proved that D17 has several unique features and that the instrument should not be closed.

**D22 New low-Q diffractometer on the cold guide H512**

All necessary steps were undertaken to finish the instrument during the year 1992. We had even planned tests with neutrons (using the spare detector of D11) for the second half of 1991. They had, of course, to be cancelled due to the reactor shut-down.

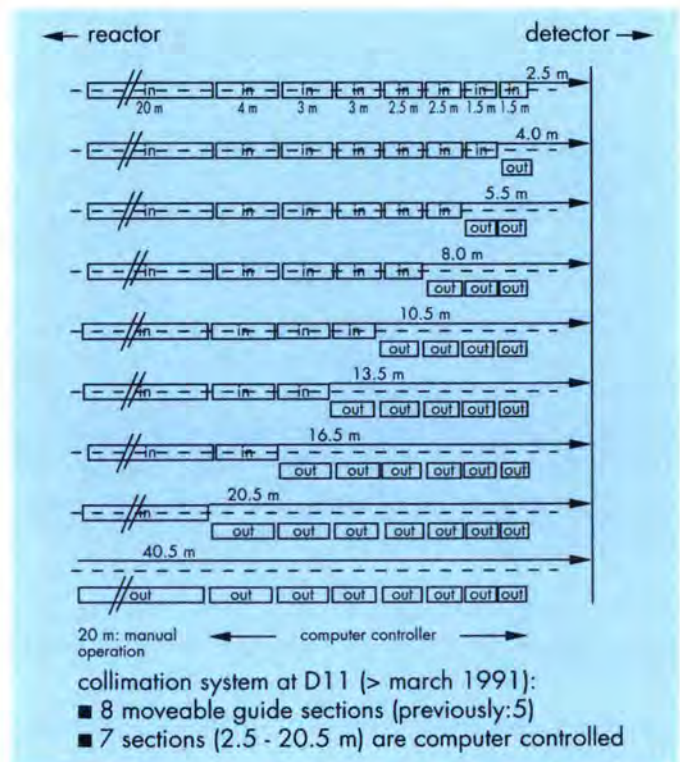

Fig. 2 : Schematic drawing of the new computer-controlled collimation system of D11.

The 17.6 m long collimation unit was equipped with neutron guides and those guides were aligned. The protection "casemate" around the monochromatizing devices was equipped with lead walls and a lead roof. A lead door on air cushions was installed.

The rails for the detector carriage damaged during the transport were exchanged, and the detector carriage was equipped with motors and encoders. Cabling this equipment is nearly finished. During vacuum tests, it turned out that the detector tube front plate is bending inside by more than 20 mm, so that it has to be modified.

The vacuum system for pumping the collimation, the sample zone and the detector tube, and the electrical and pressurized-air circuits were installed. A closed-loop water cooling system was ordered for the neutron velocity selector and the detector electronics.

The Dornier high-tech velocity selector, turning at a maximal speed of 28000 rpm for neutrons of 4.5 Å at a resolution of 10 % (FWHM), was delivered end of October, after running for 100 h at full speed. It will now be tested at the ILL and installed in the casemate. Its mechanical support, and devices for monitoring its vacuum, vibrations and temperature are being studied.

The selector rotation, the collimation movement, the vacuum and the cooling systems are controlled by an industrial process controller; the current state of all these devices is supervised by a program (InTouch) running on a PC compatible under Windows. Parameters relevant for the neutron scattering experiments will be set by the user interface program on the instrument computer. A second-hand Vaxstation 3200 was purchased from the ESRF for this purpose and installed in the instrument control cabin. The data acquisition and shaft-control electronics (VME) will be provided by the ILL electronics group in early 1992; programs written for it by the ILL instrument informatics group will be tested subsequently. The user interface will be compatible with that of D11 and D17.

Apart from the delivery of the 1 m x 1 m detector with 16K resolution elements of 0.75 cm x 0.75 cm from CERCA, now foreseen mid 1992, we are still missing mechanical items like the beam-shaping device in front of the sample, the entrance cone to the detector tube, the beam-stop mechanism, and all of the sample environment, including a platform serving for ancillary equipment and as a support for the radiation protection.

Coordinators: A.J. Dianoux  
R.P. May

### References

- [1] J.C. Cook, W. Petry, A. Heidemann, J-F Barthélémy, Nucl.Inst & Methods A312, 553 (1992).

## Diffraction Instruments

- D1A: High resolution powder diffractometer on thermal guide H22 (A.W. Hewat, M. Kocsis, J. Davies).
- D1B: Two-axis diffractometer with multidetector on thermal guide H22 (C. Ritter, B. Ouladidaf, K. Ben Saidane).
- D2B: Very high resolution powder diffractometer on thermal beam H11 (T. Vogt, A.W. Hewat, J. Davies).
- D3B: Two-axis polarized neutron diffractometer with lifting counter on thermal beam H5 (F. Tasset, P. Feder).
- D4B: Disordered materials diffractometer sharing the hot beam H8 with IN1B (P. Chieux, P. Palleau).
- D9: Four-circle diffractometer on the hot beam H3 (M.S. Lehmann, Y. Cernenkov (in part), A. Loken).
- D10: Four-circle triple-axis spectrometer on thermal guide H24 (G. McIntyre, T. Brückel, R. Chagnon).
- T12: Neutron camera on thermal guide H23.
- D15: Four-circle MK6 diffractometer on the inclined thermal beam IH4 (J. Brown, M. Reehuis, G. Schmid).
- D16: Four-circle MK6 diffractometer on cold guide H16 (G. Zaccai, V. Rodriguez (in part), R. Gay.)
- D19B: Multidetector diffractometer for protein crystallography on the thermal beam H11 (S.A. Mason, S. Bramwell, D. Robinson (in part), A. Loken (in part)).
- D20: High-flux multidetector on the thermal beam H11 (J. Pannetier, P. Convert, J. Torregrossa).
- DB21: Four-circle diffractometer with PSD for biological macromolecules on the cold guide H15 (C. Wilkinson (EMBL), E. Pebay-Peyroula, P. Agnès), CRYOPAD Cryogenic Polarization Analysis (F. Tasset, P. Feder).

### D1A High resolution neutron powder diffractometer on thermal guide H22

Due to the long reactor shutdown, we proposed to move D1A to another neutron source. Both LLB Saclay and HMI Berlin expressed strong interest, and finally an agreement was reached to transfer this popular diffractometer to Saclay for the duration of the ILL reactor rebuild. Saclay will pay the estimated 250 000 FF installation costs, while ILL will provide a technician on detachment to help run the machine.

ILL will also finish early in 1992 the 25-detector bank, which will be especially useful at the lower flux reactor. In this way we will strengthen relations with our Associate's laboratories, while maintaining our large community of users during a difficult period, working on subjects as diverse as superconductors and magnetic structures, zeolite catalysts and stress analysis.

In 1991, Dr J.-K. Cockcroft left ILL after working as co-responsible on D1A for several years. Dr Cockcroft's salary was paid by Professor A. Simon of MPI Stuttgart in return for D1A beam time. He also greatly contributed to helping users of other ILL machines such as D1B and D2B. We are very grateful to Professor Simon and Dr Cockcroft for their support of D1A. Without this, and without money earned from industrial research, it would not have been possible to continue operation of D1A, despite the good science it continues to do, because of the limit of 30 instruments that can be supported by ILL.

**D1B Two-axis diffractometer with multidetector on thermal guide H22**

Major parts of the data acquisition electronics of the D1B-Banana detector were exchanged in spring 1991. Final tests could, however, not be completed due to the unforeseen reactor shutdown. Among about 20 experiments successfully performed in early 1991 one was, unusually, a temperature dependent texture study.

Despite the abundance of successful experiments covering wide scientific areas, the future of D1B is uncertain as the planned modernisation programme inevitably necessitates the closure of existing instruments. The user meeting in October 1991 in Uriage saw, however, strong support emerging for the continuation of D1B at least until D20 has proved its aptitude to fully replace D1B.

**D3B Two-axis polarized neutron diffractometer with lifting counter on the hot beam H4**

Largely refurbished within the context of the "Second Souffle", D3B has been successfully operated at the Hot-Source position H4 during the last 4 years. Highlights in the experimental programme during this period included the observation of the quenching in induced spin-densities at 10 Tesla in High Tc superconducting materials, the measurement of electronic densities in non-centrosymmetric crystal-structures using the Schwinger interaction term (a complementary tool to X-ray scattering), and the systematic investigation of spin/orbit proportions in 3d/transuranic alloys in close connection with itinerant electron theory. Many experiments have also been done in the field of magnetic densities for the study of the chemical bond.

In view of the reactor repair we now have to completely dismantle this instrument. We shall take the opportunity of introducing a stronger rotation axis (bought from the Harwell sales) in order to strengthen the cryomagnet

positioning. An improved "in-shield" magnetic collimator replaces the existing one, which, having been used for twenty odd years, exhibits non-negligible radiation damage and radioactivity.

**CRYOPAD Cryogenic Polarization Analysis**

This unique device for General Polarisation Analysis, was being intensively used during our allocated period at the IN20 host instrument. Six years of episodic confrontation with such a novel method, the need for a precise understanding of the various aspects of data collection and interpretation, result in some undisputed success in solving difficult antiferromagnetic non-collinear structures. It is to be noted that the first design for the cryostat, although critical in a technique using Meissner superconducting magnetic shields, stayed close to its original form. New ideas for a design providing substantial simplification in the cryostat, a larger sample chamber with better access and room for high or very low temperature environment are to be implemented. These practical aspects, together with an increased precision on polarimetry, should open new fields to the method such as the study of nuclear order, magneto-elastic and inelastic effects, and critical scattering.

**D10 Four-circle triple-axis spectrometer on the thermal guide H24**

A new heavier  $\omega$ -rotation turntable, which can support the new offset open  $\chi$ -circle or any of the heavy cryomagnets, has been installed. Modifications to the electronics to drive the five-phase stepper motors of these new rotations are being made. The new four-circle dilution cryostat has been completed and is under test by S. Pujol. While minor modifications appear necessary to achieve the goal of 0.1 K, the first tests have been very promising.

**D15 Four-circle diffractometer on the inclined thermal beam IH4**

The second cycle of operation in 1991 saw the re-installation of the 32x32 pixel multidetector on D15. Although the time available for testing was rather short, first indications suggest that its stability has been much improved by the change in the composition of the gas with which it is filled. The uniformity of response was less satisfactory, varying by more than 25% for some pixels. It is hoped that this can be improved by modifications to be carried out during the reactor shut-down.

Amongst the successful experiments carried out in 1991 were the determination of the magnetic structure of Gd<sub>2</sub>CuO<sub>4</sub>, the first of this family of cuprates to have a (000) propagation vector, and a very fruitful study of the stability of the magnetic structures of TbMn<sub>2</sub> in an applied magnetic field. Both of these are described in more detail elsewhere in this report.

**D16 Low-Q diffractometer on the cold guide H16**

Experiments performed on D16 in 1991, up to the reactor shutdown, have covered a large variety of subjects requiring good Q-resolution at low Q values ( $\sim 0.05$  to  $2.0 \text{ \AA}^{-1}$ ) such as polymer solutions, protein interactions, natural and model biological membranes, surface lattices and intercalated compounds, micro-emulsions, etc.

An extensive rewriting of the two-circle experiment programs has been carried out, in order to improve and facilitate data acquisition and analysis. A new manual for the use of D16 is in preparation. This manual will include a complete up-to-date description of the diffractometer environment and software for the different types of application. A beam stop will be mounted in front of the D16 position sensitive detector ( $64 \times 16$  wires) to optimize the instrument for SAS experiments, for which there is a heavy user demand. The horizontal displacement of the beam stop and its position will be controlled by CAMAC to allow automatic positioning during scans.

During the long reactor shutdown we are planning a complete realignment of the monochromator-filter-sample table as well as the "casemate" (multiwavelength monochromator shielding block). We shall also be studying the possibility of extending the use of the diffractometer to study the Q-distribution of neutron diffuse scattering in protein crystals, in order to estimate its inelastic component.

**D19 Multidetector single crystal diffractometer on the thermal beam H11**

The long-awaited go-ahead to order a  $20^\circ \times 64^\circ$  curved position-sensitive detector for D19 was obtained at the end of 1990. The detector will be a factor of 2 closer to the sample than the old  $4^\circ \times 64^\circ$  detector and will have 100 vertical cathodes and 300 horizontal anodes in 8 atm.  $\text{He}^3$ .

Construction by CERCA (Romans) should be completed in Spring 1992 to be followed by neutron tests at an appropriate reactor in Summer 1992. The new detector shielding will be built to allow possible addition of two further identical detectors at a later date. This would give in all a factor of 20 increase in measurement efficiency.

**D20 High-flux multidetector diffractometer on the thermal beam H11**

In the beginning of 1991, D20 was still operating with its small detector (126 cells) and its work load was as usual almost equally shared between three fields of science. For the first two cycles, D20 was used essentially for magnetic structure investigations and for studies on liquids and glasses. The former experiments (23 days) used the longest wavelength available on D20 ( $\lambda=2.4 \text{ \AA}$ ) and were performed in cryomagnets or dilution cryostats. Most experiments on disordered systems (30 days) used the shortest wavelength range ( $\lambda=0.9 \text{ \AA}$ ) which complements the range available on

D4. Six experiments on stress or texture measurements were planned for the third cycle of 1991 and could not be performed due to the shutdown of the reactor.

**DB21 Four-circle diffractometer with PSD for biological macromolecules on the cold guide H15**

DB21 was previously equipped with a PDP11/24 computer which controlled diffractometer movements and was the primary data acquisition device. Since the available addressing space from the RSX11 system of the PDP11 is limited to 34 K words, it was not possible to hold all of a frame of data in memory at the same time and this made it impracticable to do anything but a very preliminary amount of data processing on the instrument.

In order to display data graphically at the time of measurement and to facilitate data transfer, the PDP11 has been replaced by a Microvax II computer (with colour graphics terminal) having a direct ethernet connection to the IZAR cluster. This enables the data treatment (including compression for more efficient storage) and display to be brought into line with that on the D9, D15 and D19 diffractometers and allows access to the programs which have been developed for the multidetectors on those instruments.

DB21 normally operates with a potassium-intercalated pyrolytic graphite monochromator, which at  $90^\circ$  take-off angle gives  $7.56 \text{ \AA}$  neutrons, allowing materials with large unit cells to be measured at  $15 \text{ \AA}$  resolution. Tests have shown that with a conventional pyrolytic graphite monochromator, which gives neutrons of  $4.75 \text{ \AA}$  wavelength, higher resolution ( $\sim 5 \text{ \AA}$ ) data from materials with smaller unit cells can be successfully collected on the instrument.

During the long shut-down, a carousel carrying different monochromator crystals is being mounted to make available a range of wavelengths on the instrument, and the possibility of installing a second (fixed) high-angle position sensitive detector to increase data collection rates is being investigated.

Coordinator: C. Zeyen

*There were no contributions for D4B and D9.  
(The Editor)*

## Special instruments and experiments

Most of the special instruments and experiments were in routine operation at the time of the reactor shut-down. The new situation where there are no neutrons and effectively no funds available or obtainable is generally considered to be a disaster. So the main improvements and developments may therefore be summarized as follows:

**S21** Was operated exclusively in the Ultra-Small-Angle mode. This option will be improved by a new set of crystal goniometers, tilt mechanisms and automated sample changer (all purchased from the German company PI) and operated from the S21 PC via an IEEE interface.

**S51-INAA** During the year a system for raising and lowering the liquid nitrogen dewars to the basement of ILL1 was installed, which has greatly facilitated what was a fairly onerous task. 1991 also saw the installation of a special spectrometer for the detection, in a low background environment, of naturally emitted gamma-rays from the actinide series.

These measurements permit the dating of recent rocks and will add to the ability of geologists to determine the date of geological events.

The **neutron-antineutron** oscillation experiment stopped taking data; data evaluation is underway to determine the exact value of the confidence limit for the oscillation time.

In the field of **very cold and ultra-cold neutron physics** we can summarize the progress as follows:

Great effort was put into the understanding of improved wall coverings for neutron bottles. In the framework of the development of a **superthermal source** the use of deuterated polystyrene was studied in more detail. It was found that one has to make the DPS layer as thin as possible (several hundred Angstrom) in order to get a DPS surface that sticks well to a stainless steel surface. A computer controlled layer deposition device has been successfully constructed which is able to paint a solution of deuterated toluol and DPS (1000:1) on the inner surface of stainless steel tubes of up to 3m length.

The gravity spectrometer **NESSIE** was tested successfully with a sample of dilute solutions of ferritine molecules in heavy water; the diffusion constants as determined with ultra-cold neutrons were confirmed by dynamical light scattering.

The construction of an improved neutron bottle (**MAMBO II**) is well in hand: its design has been fixed and construction of the apparatus is progressing as well as computer simulations by Monte Carlo calculations.

The **VCN-interferometer** was equipped with a precision inclinometer and work on the active levelling system has

continued. The precision of the linear positioning stages for the gratings was shown to be problematic. It is intended to replace them by more precise "flexure" stages. As concerns the active vibration isolation system, two ideas will be tested: one is based on the "super spring" design and the other on a dynamical increase of the mass of the optical bench with both designs decreasing the resonance frequency in the low frequency range around 1 Hz.

The new instrument for the precision determination of the electric dipole moment of the neutron (**EDM**) as shown in Fig. 1 is nearly completed, and the period of testing and refining has begun. The aim is to improve the precision by a factor of 5 with the progress coming almost equally from reductions in systematic and statistical errors. - Ramsey oscillations with stored neutrons with the new 22 l storage cell were obtained in January 91. The conclusion is that 90% of the initial neutron polarisation can be maintained after 120 s of storage. The statistical precision for the measurement of the neutron precession rate was better by 50% compared with the previous experiment. It is expected that the use of neutron guides coated with  $^{58}\text{Ni-Mo}$  will increase the neutron counts by a factor of 3. Much effort went into the development of the new optically pumped Hg magnetometer intended to reduce the systematic errors by giving a precise and continuous measurement of the magnetic field averaged over the storage cell. Fig. 2 shows

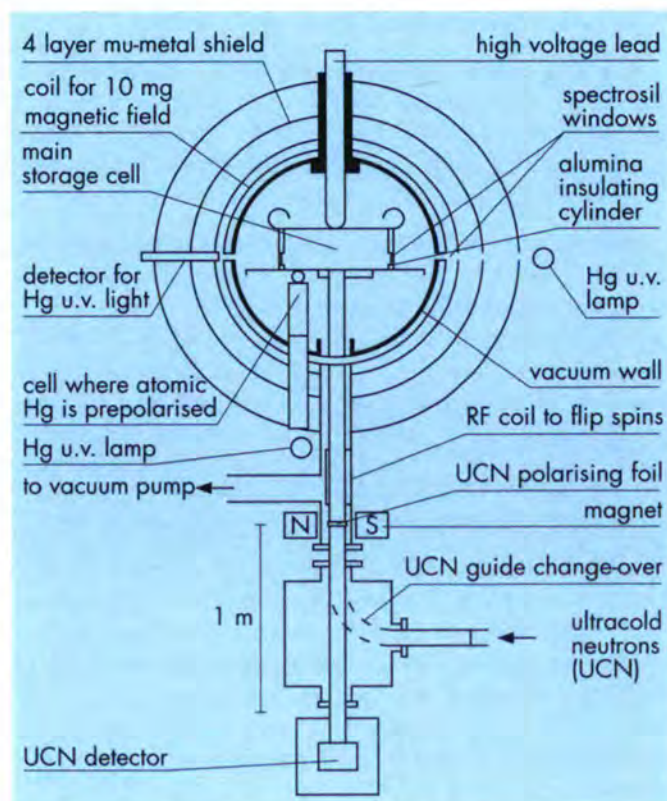
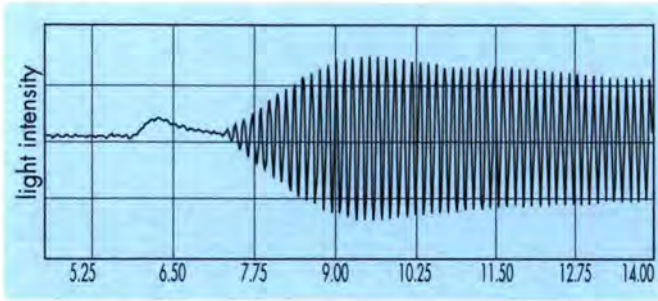

Fig 1: The new instrument to measure the neutron electric dipole moment.



*Fig 2: A nuclear precession signal for  $^{199}\text{Hg}$  in a first trial of the mercury magnetometer for the neutron EDM instrument. The trace shows the intensity of ultraviolet mercury resonance light transmitted through the 22 litre storage cell containing  $2 \times 10^{-6}$  torr of mercury  $^{199}$ . The small precursor bump is caused by the increase in absorption when the mercury vapour enters the cell.*

some data obtained in first tests. The plot is actually the intensity for a beam of UV mercury resonance light which passed through the cell. The trace reveals, in real time, the variation of the x-component of magnetisation for  $\text{Hg}^{199}$  nuclei. The oscillatory part corresponds to a free precession at 8 Hz. The precession signal appears as the magnetisation is turned from the z-direction into the xy-plane by a 2 s period of magnetic resonance. It is expected that the signal to noise ratio in a bandwidth of 2 Hz can be improved from the present 180 to 1000. Much more remains to be done: to study the role of surface interactions of the Hg atoms and then to make a detailed examination of the stability of the main magnetic field and the extent to which it might be influenced by the electric field system.

Coordinator: W. Drexel

- SCIENTIFIC COORDINATION AND PUBLIC RELATIONS p. 108
- SAFETY, MEDICAL AND HEALTH PHYSICS GROUPS (SPS) p. 109
- JOINT ILL-ESRF LIBRARY p. 110

## Scientific Coordination and Public Relations

### Scientific Programme

The beam-time allocation for 1991 could not be completed due to the unforeseen reactor shutdown. About a third of the usual experimental programme was carried out in the one and a half cycles of neutron supply. Since ILL's activity in 1991 cannot be compared with previous years, this chapter does not include its usual statistics.

In the last two years we registered a larger number of scientists (about 600) asking for beam-time at the ILL. Fig. 1 shows the distribution of the different nationalities of scientists requesting beam-time, only for the years 1990 and 1991 (i.e. the Scientific Councils of April/October '90 and April '91).

Over recent years (last update was in 1988) we registered scientists from 37 countries, see Table 1.

Algeria	Argentina	Austria	Australia
Belgium	Bulgaria	Canada	China
Czechoslovakia	Denmark	Finland	France
Germany	Great Britain	Greece	Hungary
India	Indonesia	Ireland	Israel
Italy	Japan	Morocco	Netherlands
Norway	Pakistan	Poland	Portugal
Saudi Arabia	South Africa	Spain	Sweden
Switzerland	Turkey	USA	USSR
Yugoslavia			

Table 1

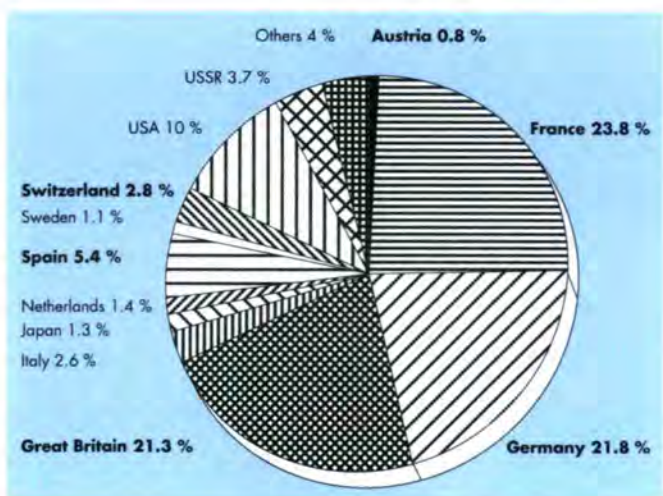

Figure 1: Number of ILL users requesting beam time in 1990/91.

### The ILL Users' Meeting

This was the first in ILL's history. About 270 scientists from 15 countries gathered at the users' meeting which was held on 17 October 1991 in Uriage-les-Bains, about 15 km from Grenoble. It was a successful get-together demonstrating the great interest of ILL's users in its future.

The topic of the meeting was the ILL modernisation programme (details are described in the last ILL 'News For Reactor Users' N° 21, July 1991). Different aspects of the modernisation programme were presented in the morning. The afternoon session was divided in two parts: firstly, discussion in the subgroups by Colleges and afterwards a general discussion. Details of the meeting can be found in the ILL report 91IL23G.

The following conclusion may be drawn: for fundamental and nuclear physics, the instruments PN1, PN3, and PN4 remain scheduled instruments. Due to the reactor refurbishment a reinstallation of PN2's (BILL) special beam-tube is not envisaged. It is proposed to reinstall this conversion electron spectrometer as one of the optional instruments at the new PN7B facility. In future, nuclear spectroscopy will have two scheduled instruments, not three as up to now. Demonstrating a shift to fundamental and elementary particle problems it is proposed to convert the UCN facility, which is in great demand and unique in the world, into a scheduled instrument PN9. Fundamental physics would then have two scheduled instruments, PN7B, shared with nuclear physics, and the UCN facility PN9.

There will be 8 single crystal and 3 powder diffraction instruments. The proposed shutdown of D1B as scheduled instrument did not meet with the unanimous consent of the users. No shutdown of D1B without a new detector operational on D20, no shutdown of D1A without a better monochromator at D2B. These measures for the highly successful powder diffraction technique have to be financed within the normal budget.

The 5.5 elastic and quasielastic scattering instruments were supported unanimously. The SANS community regrets that D17 is to be 'de-scheduled'. The remaining instruments D11 and D22 do not cover all the aspects which D17 offers.

The 4.5 three-axis spectrometers were accepted as proposed.

The 5 TOF and backscattering instruments show the largest refurbishment effort. High-resolution spectroscopy will still remain in its predominant position in the future. The loss of IN13 or IN10 was regretted by the community concerned. It was proposed to run IN10 and IN13 each as half an instrument. This solution is not favoured by the ILL management.

The list of 31 instruments shows that half of all the instruments will use cold neutrons. The ILL has to provide an optimum cold-neutron supply. Timely refurbishments and provisions for ILL's cold sources and guides should thus

have similar priority to the reactor itself. Sample environment or up-to-date pressure cells should not be neglected. Better monochromators for the existing instruments and the completion of the D20 detector were explicitly called for.

For the instruments to be financed within the normal budget for new instruments and major upgrades: zero-field spin-echo (ZENSE) found large support, and the same holds for IN4C and PN3 (GAMS5). The polarised hydrogen target led to a long debate in colleges 8 and 9b, and the issue is still open. The interferometer on the supermirror thermal guide requires an early decision of approval in principle as its vibration-free support must be installed before the guide is mounted.

Provision for the positron source was supported, so that implementation would be possible at a later stage.

#### Workshops and Conferences in 1992

The following workshops are planned in 1992:

- Journée des Polymères et des Colloïdes  
Organisers: P. Lindner, E. Geissler  
ILL, March 1992
- "2nd European Workshop on neutron, X-ray and light scattering in colloidal and polymeric systems"  
Organiser: P. Lindner  
Bombannes (France), June 1992
- "Determination of partial structure factors of disordered matter by neutron and anomalous X-ray diffraction".  
Organisers: P. Chieux, J.B. Suck, D. Raoux  
ILL, 8/9 September 1992
- "Applications of high resolution  $\gamma$ -spectroscopy in studies of atomic collisions and nuclear lifetimes"  
Organisers: H.G. Börner, J. Jolie, M. Pendlebury  
ILL, October 1992

## Safety, Medical and Health Physics Groups (SPS)

### Health Physics and General Safety Units

As in previous years, the Health Physics and General Safety Units have carried out their work of verification and assistance to the Reactor Division, the Departments and Scientists at the ILL.

The main features in 1991 were:

- Setting up a training system for all ILL staff in nuclear and non-nuclear safety. This training is given during two one-day sessions per month, one in French, the other in English. In this connection the documentation on Health Physics and Safety has been updated.
- Purchase by the Health Physics Unit of 200 portable audible dosimeters for better monitoring of the dose received.
- Radiation protection monitoring of persons working on the investigation phase and evaluation of the state of the High Flux Reactor.
- Continuation of a training policy for the staff (training in electricity).

### Works Medical Service

Following the agreement of 26.3.91 between ESRF and ILL, the Medical Service became the "Joint Works Medical Service" with responsibility for the staff of ESRF, EMBL and ILL. The Regional Employment Directorate gave its approval to the Joint Medical Service of 12.9.91.

An ophthalmological examination room opened in September 1990 for specific eye examinations. These are carried out by a visiting specialist.

It may be recalled that the Medical Service is responsible for monitoring personnel in the medical field (regular and additional medical examinations, medical risks associated with working conditions, individual radiological dosimetry, toxicological monitoring).

Medical attention is given more than 3000 times per year in the Medical Service.

## Joint ILL-ESRF Library

1991 Scientific Literature Budget 1050.4 KF

ILL: 72,5%, ESRF: 27,5%

Following the "Agreement on the operation and management of a Joint ILL-ESRF Library", the ESRF contributed 27,5% for 1991 to all library costs and acquisition was increased.

More books and journals were bought in order to meet the need of ESRF scientists in particular in optics, instrumentation and, of course, synchrotron radiation research.

A total of 870 books were processed

- 500 for the Joint Library
- 120 deposited with ILL departments
- 250 deposited with ESRF divisions.

The number of computerized literature searches increased from 60 to 200.

The project of automating library services, started in 1989 and under the ESRF responsibility since mid 1991, resulted in the purchase of the software "LORIS-DORIS", approved by the two Institutes. Implementation will take place in 1992, which will be also the year of moving the library to the new "Joint ILL-ESRF building". It is hoped that the library staff will be increased soon, as the small team presently available is largely insufficient.

### ILL publications

If the reactor shut-down resulted in a decrease in the number of experiments performed in 1991, due to the delay between measurement and publication, the number of publications was not yet affected. Furthermore, scientists were able to devote more time to data treatment and subsequent work.

Number of Publications 1991:

Published (includes 60 without ILL authors):	480
Accepted:	<u>170</u>
	650

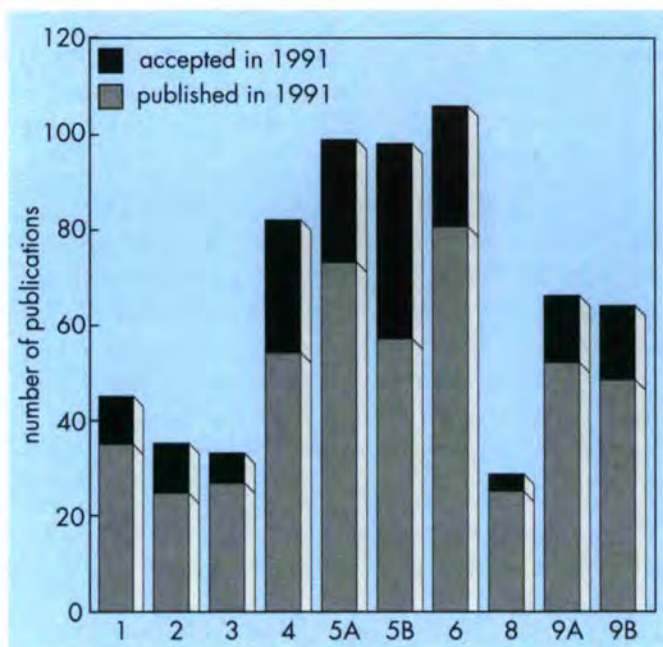

- 1 - Instruments and methods
- 2 - Theory
- 3 - Fundamental and Nuclear physics
- 4 - Excitations
- 5a- Crystallographic structures
- 5b- Liquids, disordered materials
- 8 - Biology
- 9a- Chemistry- Small molecules
- 9b- Chemistry- Colloids and polymers

<i>– MECHANICAL ENGINEERING</i>	<i>P. 112</i>
<i>– ELECTRONICS GROUP</i>	<i>P. 112</i>
<i>– MONOCHROMATORS</i>	<i>P. 113</i>
<i>– MULTIDETECTOR GROUP</i>	<i>P. 113</i>
<i>– MULTILAYER LABORATORY</i>	<i>P. 114</i>
<i>– OTHER ACTIVITIES</i>	<i>P. 114</i>

## Mechanical Engineering

### General

In 1991, the working conditions of the Mechanical Engineering were considerably enhanced by a new organisation consisting of:

the recruitment of a young mechanical engineer to directly lead the Design office;

to group together the staff of the mechanical workshop and the assembly hall in a unique entity led by a senior technician.

Simultaneously this new group has been placed under the responsibility of an engineer having a long practical experience in collaborating with scientists at ILL. This new management permits the introduction of certain ideas borrowed from the "quality concept".

In 1991 the life of the Mechanical Engineering Group was considerably affected by a major renewal of staff. Although its functions are unchanged, this renewal was sufficiently extensive to enable the group to view its task from a new perspective. This change consisted of gradually introducing certain ideas borrowed from the "quality" concept.

### Drawing Office and finite element calculation laboratory

#### *Drawing Office*

The effort to introduce CAD has been and will be maintained. It was reflected this year by the commissioning of two AutoCAD workstations.

A particular effort has been made to define and plan the design work which is necessary to complete construction of the instruments IN10C, IN15 and D22. The first two of these have been completed at the end of 1991.

The study for the shielding of the multidetector D20 was the subject of a sustained effort to permit maximum progress on this project (installation of the electrode system in 1992).

A new project has been started - the time-of-flight spectrometer IN4C - the first elements of which (primary spectrometer) should be installed in position (thermal beam tube H12) at the reactor restart (1994).

The drawing office is now equipped with the latest version of the 3D solid CAD system (EUCLID-IS (2.2A) on VAXstation and AUTOCAD (11.0) on PC and VAXstation.

#### *Finite element calculation laboratory*

The aim of this laboratory is to deal with the mechanical problems associated with the construction of instruments, but also to assist in the sample environment design work (cryostats, cryo-magnets, furnaces, pressure cells, etc.) and in the definition of systems associated with the reactor (the hot source, for example).

In 1991, many problems were explored: in non-linear mechanical engineering (large deformation, stress stiffening, plasticity, etc.); in static and transient non-linear thermal analysis (hot source, taking into account radiation phenomena), in static electro-magnetism (study of the field and structures of the future ILL 10 Tesla cryo-magnet).

The laboratory makes use of the enormous potential of the ANSYS finite element software operating on workstations DEC 5000 and 3100 (Ultrix).

The finite element method software package ANSYS release 4.4 A was installed on a UNIX platform with a server-diskless-client configuration (DECstation 5000/200 CX and DECstation 3100).

### Workshop and Assembly hall

This sector is also led by a new staff member. Although its staff has been reduced, this group retains the same functions :

*Assembly, preparation, machining and maintenance*

Assembly of the analyser and shielding for IN10C;

Assembling of the guides inside the collimation and commissioning of the vacuum system in the various parts of D22;

Installation on IN5 of the "Brillouin option";

Installation on D11 of a new non-magnetic collimation;

Balancing of choppers on IN15 and velocity selectors on D11 and IN11;

A particular effort was made on characterizing drive motors for choppers and velocity selectors. The group is taking an active part in the dismantling phase of the instruments in the reactor and in the commissioning of new neutron beam shutters designed, built and installed in the framework of Quality Assurance.

#### *Manufacture and mechanical metrology*

Mechanical metrology is now dealt with by staff of the workshop.

Apart from the day to day work of the workshop, mention should be made of its efficient contribution to the effort of identifying the reactor failure in the spring of this year.

## Electronics Group

Two major events occurred in 1991, which are liable to have a profound influence on the orientations of the Electronics Group as regards equipment and maintenance.

1. The long reactor shutdown, resulting in the instruments being inactive and some of them being completely dismantled.

2. The decision taken, within the framework of the necessary collaboration between ESRF and ILL, to envisage the progressive utilisation of the UNIX operation system on the instrument control computers.

This latter decision confirmed the choice made by ILL in 1984 to introduce the new electronics standard VME, and favours the acceleration of the conversion of the CAMAC electronics to the new standard. The shutdown of the instruments offers an exceptional opportunity for intervention work, while the strict budgetary restrictions necessitate the optimization of the choices.

In this context in particular the studies for the replacement of the coding electronics on instruments IN1 and IN8 have been carried out.

In 1991 the equipment for instrument control electronics was continued and in some cases completed:

D22 with in particular the commissioning of a VME industrial programmable logic controller;

IN15 with the first control tests on choppers and velocity selectors (including the TOF version supplied by the Jülich centre);

IN10C

The study for the improvement of the electronics of IN4 for adaptation to the new instrument IN4C (data control and acquisition in VME).

The Electronics group played an important part in the dismantling of the instruments in level C, thus ensuring that they can be satisfactorily reinstalled within a limited time.

## Monochromators

From August 1991 the staff of the group has been significantly reinforced by a senior technician.

The work of the Group, as in the past, has been dominated by the development, construction and alignment of monochromators for instruments at the ILL, e.g. for IN4, IN10, IN10C, IN12, D2B, D9 and S21. Some of these projects, like the Ge-monochromator for D2B require general improvements to the equipment. It was realized that the quality of the hot press usually used was no longer sufficient for the fabrication of this device. A complete overhaul and extensive testing were performed and the hot press is now ready for further use.

Research projects such as development of Si-Ge gradient crystals and the use of Be as a monochromator have been continued throughout the year. It should be mentioned that the production rate of the Be crystals at the MPI-Stuttgart is now at a reasonable level. However, the plastic deformation of this material still gives headaches. Mosaicity can be created on various crystal planes and their properties depend on details of the deformation mode such as temperature. However, all the crystals contain grains and the plastic deformation seems to be dominated frequently by gliding along grain boundaries. We have now started to study plastic deformation at higher temperature where it is likely that the creation of an appropriate micro-structure is favoured with respect to macroscopic gliding.

The consequences of the unexpected shutdown of our reactor have been faced by a rapid transfer of one of the test diffractometers of the group to a beam position at the Siloe reactor (CEN-Grenoble). Crystal testing and alignment can be carried out to some extent at that station. Also there is a very strong demand from the general users' community for this diffractometer. In spite of this possibility of working at Siloe, the lack of a high-quality test beam-line does cause problems. In view of the reduced neutron beam-time we have also put a versatile X-ray diffractometer (with J. DAVIES on temporary assignment) into operation. It is already heavily used for the purpose of the group and also by scientists.

During 1991 the crystals for one Heusler monochromator have been made for an external institute (PSI-Würenlingen). It should be noted that ILL was provided with the entire manpower needed for this project, on a collaborative basis.

## Multidetector Group

### *Microstrip Gas Detectors*

The gas detector developed at ILL with microstrip anode (MS-anode) [1] has recently aroused great interest. More than 10 different research groups, spread over the whole world, are already working with this type of detector, either to use it or to further improve its capacity.

The essential characteristics of this new gas detector are:

High counting capacity (comparable with that of a multiplier) with good energy and position resolution.

The detector of the powder diffractometer D20 at ILL is based on this technology (cf Annual Report 1989). The curved, 5 m long detector housing is equipped with 50 MS-anode plates with a surface of (18 x 8) cm<sup>2</sup>. All the glass plates are cut with an accuracy of ± 20 micron, to ensure a continuous transition from plate to plate over the complete detector entry window. The plates are currently being cleaned and tested at the manufacturer. Installation is planned before the end of the year. The housing has already been degassed for the first time, and completion of the detector is anticipated for mid-1992.

Recent measurements with a small test detector gave the surprising result that the MS-anode works well in pure noble gases or noble gas mixtures. Without any quenching gas the light emission generated by avalanches on the MS-anode surface is therefore high. For example, a particularly high emission in the visible region can be obtained with 90% Krypton and 10% Xenon. With a Peltier cooled camera [2] there was no problem in detecting light emitted from the gas-amplified signal of alpha particles. For neutrons the light output in a 20% <sup>3</sup>He, 40% Kr and 40% Xe gas mixture at 1 bar was 70 times greater than the light emission of a <sup>6</sup>Li glass scintillator (NE 904) [3]. These results suggest the combined use of an MS-Plate and CCD as a position sensitive n-detector, but further investigations should be made (see Fig.).

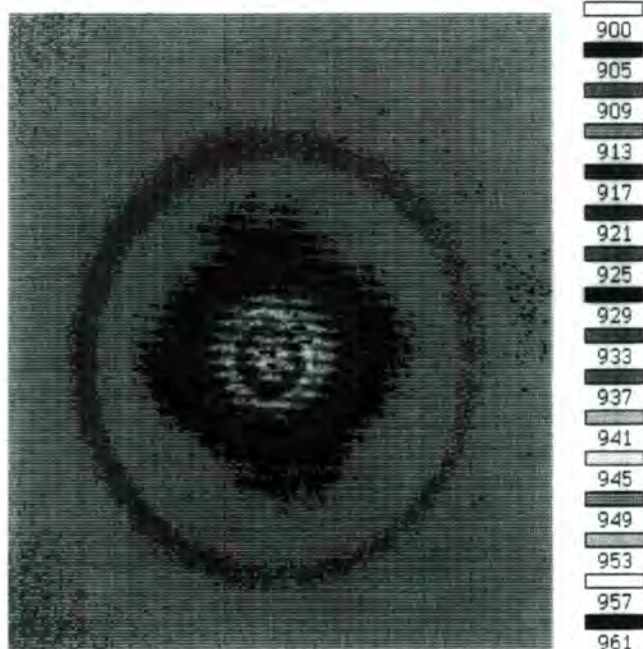

Visible light emission of a micro-strip-anode irradiated with  $\alpha$ -particles and recorded with a CCD camera.

### Monitors

The technology transfer to industry continues. IN15 and IN10C currently use  $^{235}\text{U}$  flat monitors and  $^3\text{He}$  versions of these monitors (thickness 1 cm) with thin windows (0.5 mm) are now available.

The detector group is continuing the construction and development of multiwire proportional counters.

### Small angle detector

A prototype angular detector, using the wire chamber technique, is under construction. It will have 18 cells distributed over three  $45^\circ$  sectors and radially over 6 arcs of circles with radii varying from 85 to 185 mm by steps of 20 mm. Each arc of a circle is represented approximately by 2 consecutive sides of a regular 16 sided polygon. It should be ready at the beginning of 1992. It will be filled with 7.2 bars of  $\text{He}^3$ , which will give it an efficiency of 70% for 1.5 Å neutrons, on the basis of a detection gap of 15 mm.

This prototype is intended for testing and improving the internal structural parts of the future small angle detector for IN4C (96 cells on 8  $45^\circ$  sectors and 12 rings with radii between 85 and 315 mm).

- [1] A. Oed, NIM A263 (1988) 351
- [2] The CCD camera was kindly made available by V. Comparat, ISN, Grenoble
- [3] P. Geltenbort and A. Oed, Aussois Workshop (1991)

## Multilayer Laboratory

The operation of the laboratory equipment, two electron beam evaporators and the neutron testing facility, was influenced by the reactor shutdown. The Electrotech evaporator has been operated continually without major breakdowns.

The time on the Electrotech evaporator was spent mainly on the production of polarising Ti-Co supermirrors for a large analyser system designed for the new IN15 Spin-Echo Spectrometer. Thin glass substrates with dimensions up to  $305 \times 300 \text{ mm}^2$  were coated to produce 29 supermirrors of  $700 \times 305 \text{ mm}^2$  surface area.

The Riber evaporator was used to produce polarising Ti-Co supermirrors, coated on both sides, for the Institute for Solid State Physics of the University of Tokyo and Ni-Ti supermirrors for the Physics Department of the Technical University Munich (U. Schmidt).

On the testing facility, 25 % of the IN15 supermirrors and all the supermirrors for the University of Tokyo were tested before the reactor shutdown. The facility was used also by the Monochromator Group (U. Grüning, A. Magerl) for reflectivity measurements on Si wafer stacks coated on both sides with Ni and CILAS for measurements on industrially produced supermirrors. Alternative testing facilities at the FRM Garching (Germany) and PSI Würenlingen (Switzerland) are under examination.

### Publication

- [1] O. Schärpf, "Thin film devices and their role in future neutron spectroscopic investigations" Physica B 174 (1991) 514-527

## Other Activities

### Neutron guides

The replacement of the 18 m long collimation section of the D11 small angle spectrometer and the mounting and alignment of the 16 m long collimation section of the new D22 small angle spectrometer was commissioned. The 40 m long prolongation of the H21 guide permitting installation of a new neutron resonance Spin Echo facility in a 'casemate' created for this purpose was finished during the reactor shutdown.

Since the reactor shutdown, the guides H22 and H23 were aligned downstream of the primary beam shutters, due to a measured loss of neutron flux.

Preliminary studies for the two new guides NG12 and NG13 on the vertical cold source were finished. The dismantling for the H1-H2 guides refurbishment during the reactor shutdown is under way.

The contribution of an engineer from the Project Office to the improvement of the new hot source should also be mentioned.

- *CENTRAL FACILITIES SERVICE* p.116
- *INSTRUMENT SERVICE* p.118

All aspects of the Department's work have been affected by the Steering Committee's decision that ILL should change over completely to UNIX-based systems.

## Central Facilities Service

### Operations

This group is responsible for the operation of the computers managed by the service. These are in three categories: a cluster of 4 VAXs for the scientific sector (VAX 8650, VAX 8700 and two VAXstations), a UNIX system based on the DECstation 5000 also for the scientific sector, and a group of four VAX and PDP11 machines used for management and office computing.

This year the group has extended its activity in the maintenance of workstations, terminals, Macintoshes and printers. A technician has been detached from the Instrument Operation Department for the period of the reactor shutdown to participate in this work. This operation has permitted a considerable reduction in maintenance contracts on this type of equipment.

The total utilisation level of the machines in the cluster this year was approximately 900 hours/month (reference VAX 8650). ESRF consumption was of the order of 60 h/month. The statistics give rise to the following comments:

- the use of the VAXes by ESRF has diminished from 240 h to 60 h/month
- there is still some visitors' activity, in particular via international networks, but this is reducing with the reactor shutdown
- the utilisation level by ILL scientists has been higher this year than last year. This may be explained by the fact that scientists have had more time available for their data processing.

At the beginning of this year a RISC UNIX DECstation 5000 machine started operation. The configuration was designed to be used as both a workstation and a treatment server. For this purpose it was equipped with peripherals which provide autonomy and security in terms of disks and safeguarding facilities. It has been mainly used for development and by theoreticians. Its throughput has gradually increased to reach over 300 hours/month at the end of the year.

### Systems and Networks

As in the past, the Systems and Networks Group devoted a considerable part of its time to monitoring the operation of the various machines, the maintenance of system software and communications products on the external networks. In this last field assistance to users has been particularly important, despite the Reactor shutdown.

The introduction of the UNIX Decstation 5000 was a major task for two members of the group. They had first to train on UNIX, then to learn the management of this new type of machine, as incorporated in the ILL network, and provide the first users with documentation, advice and tools to facilitate the day-to-day work.

Good work has been done in the field of communications, which has resulted in better integration of our equipment in both internal and external networks:

- the purchase of PATHWORKS software has permitted better incorporation of the ILL PC and MAC micros in our DECNET network ;
- ILL now forms part of the Grenoble local network known as GRENET, which offers new possibilities for communication with the University and the adjacent research centres, but also increases the need for network monitoring;
- the EARN link using the BSC protocol has been given up in favour of a DECNET connexion to the CNUSC at Montpellier. This is based on a VAXstation 3200 server via GRENET;
- the HEPNET (High Energy Physics Network) server has been upgraded to microVAX II with more disk capacity to facilitate transfers of files for our VMS and UNIX systems;
- the TCP/IP protocol has been installed on the cluster and other servers to facilitate exchanges with the local UNIX world. A connection to the INTERNET network is not yet available; the study is in progress and contacts have been made with external organisations to obtain access to this network.

Finally the group has this year taken responsibility for supporting PC microcomputers, mainly in respect of the choice of hardware and software.

### Mathematics

The NAG mathematics library has been installed on the UNIX machine. A Fortran 90 compiler has been ordered from the same Company. The new standard should facilitate the transfer of VMS programs to the world of UNIX. A special function library from Argonne has also been installed. A modelling and optimisation software package has been provided for Macintosh users.

The group has received training in the use of the CRAY at the CGCV (CENG) and in the different access procedures, and has participated in adapting certain treatment programs. There has been very little use of this machine so far, but an enquiry among ILL scientists reveals that some of them will be interested in using it in the coming months. Access to this machine is via a joint ESRF/ILL link using a SUN server at ESRF.

OPTILAB – a software package for image processing bought last year – and a slide scanner have been installed on a Macintosh IIsi (ILL) and subsequently on a Macintosh IIfx (ESRF) with a large colour screen. Several scientific studies

have already been performed mainly on neutron topography patterns. Fourier transforms performed on model images have also been found very helpful for the interpretation of neutron small angle scattering patterns (D11).

Each year more ILL physicists develop programs on Macintosh either in FORTRAN or Pascal. We thus try to provide full support as regards the use of these languages in this specific environment as well as for the use of the famous Macintosh "toolbox".

Lectures on statistics (A. Antoniadis) have been organised in the past at the ILL. A book is now being prepared by him and two other mathematicians, in which strong emphasis will be put on graphical analysis, random number generation, simulation techniques, resampling methods, dynamic illustration of regression diagnostics, robust methods, etc. We are participating with the authors in the development of a companion Macintosh computer program since we believe it will be a useful tool for physicists and will serve for future ILL courses on statistics and data analysis techniques.

### Graphics

A new Evans & Sutherland ESV3 high definition graphics station, dedicated to the molecular modelling domain, now complements the same manufacturer's existing PS300. It was bought jointly with EMBL and ESRF. This is a RISC machine, which operates under UNIX, the software used being essentially FRODO and BIOGROMOS.

To satisfy the demand for image production in 256 colours, a POSTSCRIPT colour printer has been installed, which is accessible by way of ETHERNET/DECNET and APPLE TALK.

In connection with the introduction of the UNIX station, the group has made its contribution by installing TEKTRONIX, PHIGS/GKS/NAG graphics libraries and providing methods of transposing VMS programs into the UNIX environment.

It also provides support for other products, such as PV-WAVE, VIEW and AUTOCAD, available on the VMS machines.

### Telecommunications

Following the Memorandum of Understanding of 4/12/89, ILL and ESRF signed an "Agreement on the Operation of a Joint Telephone Service", which took effect on 1/5/91. This Service is responsible for the management of the telephone systems at the two institutes.

A new telephone system was installed during the first half of the year. It consists of two OPUS 4000, one for ILL and EMBL (installed in April) and one for ESRF (installed in May). The two switchboards are organised in a network to form a unified system. The paging system has also been changed to the CONTACTOR 9000 LHF supplied by OPUS

ALCATEL. This has the advantage of integrating better with the operation of the switchboards. New facilities are available, such as recorded messages, personal calls, automatic transfer to the paging system etc.

The group also has the responsibility for the APPLE TALK network. This network, originally based on the use of telephone cables, has developed considerably during the last two years. Its operation raises certain problems, and necessitates a complete renewal of the wiring. Because of the need for budgetary savings it was only possible to reorganize part of the network this year. This effort will be continued in 1992.

### Administration and Office Computing

#### *Finance and Purchasing*

The CONCENTRATOR project, the subject of a study in 1990, which was to have been implemented this year, has been given up. This is in accordance with the Associates' request to adopt the UNIX standard for new developments and to make budgetary economies in the context of the reactor refurbishment.

However certain modifications of the present software have been carried out, and some treatments are now done in a Macintosh environment.

Reliability and security have been improved by the adoption of disk shadowing on the application data base.

#### *Salaries and Personnel*

The Group has provided continuing support in the application of the HERA software for personnel management.

#### *Office Computing*

The conversion to Macintosh has been completed for all the users of the ITOS wordprocessing system. The VAX 750 which supports ITOS will be shut down at the end of this year.

#### *Modernisation of the MISILL Applications/New applications*

The product developed by ESRF using ORACLE for handling travel and subsistence costs is being adapted for ILL. This development is being carried out internally.

A study of the project for management of joint site access is in progress, under the ILL's responsibility.

The computerisation of the joint library service has been entrusted to the ESRF.

These applications should start in 1992. They will incorporate Client/Server architecture on a UNIX machine as data server and PC type workstations for treatment.

As regards the other applications specific to the ILL (Mutuelle, dosimetry), an effort has been made to improve these products while awaiting their conversion to the new architecture.

## Instrument Service

The aims of the Instrument Service in 1991 were the same as the previous year, but many projects were affected by the reactor shutdown.

### *Maintenance*

With the considerably increased reliability of the computers, the hardware maintenance requirement has diminished, but there were many cases of installation work for the Central Facilities Service and the NUPSI group. Nonstandard equipment is frequently used on the "S" instruments, which results in long and frequent intervention work. The Department has undertaken the project of maintaining personal computers, and first-level support has been initiated.

As regards software, the variety of Macintoshes and associated software results in an ever increasing effort; there is a danger of an inflation of products, also for the PCs, as the unit cost is relatively low.

### *Development of computing on instruments*

Micro-VAX computers have been purchased for the instruments IN13, IN20, T13A, DB21, D2B and D22.

Before the reactor shutdown, the D2B computer became operational in less than one week. The developments on DB21 and IN13 are completed and have to wait for neutrons for final tests. For IN20 the test modules of the new spin-echo coils have been implemented, but the remainder of the instrument awaits a decision on UNIX policy and the replacement of the electronics. For D22, developments have started with the aim (associated with the supply of the electronics) of tests without neutrons in April 1992. For T13A, the ensemble was associated with a new VME controller based on an RTVAX chip under VAXEln; the UNIX decision has put this choice in doubt, and the study is unfinished. For the new instruments, the latest developments are in progress for IN10C, following the delivery of the final electronics modules; as far as IN15 is concerned, the ILL part is completed, and following the delivery in October of the KFA Jülich part, its integration is in progress. Considerable efforts have been made on the software under OS9 and there are no further basic problems as regards systems integration. The computerisation project for the  $\gamma$ - and X-ray test facilities has been completed and is considered extremely successful by those in charge.

The development of the local display programs for raw or treated data has continued; after the multidetector diffractometers, programs have been written for IN4, IN5, IN6, D11 and D17. The basic problem is the future of PV-Wave at ILL, as all these programs are based on this product.

### *Internal networks*

The work on networks has been very considerable during 1991; a larger part of the work is now rationalised within the Service: wiring of building ILL7, ILL1 (mechanical engineering part), part of ILL4, and part of ILL21. Many projects are in preparation (continuation of ILL4, ILL20, ILL17, ILL1 nuclear physics part).

Part of the management of the Appletalk network has been taken over, in particular that of the Appletalk/Ethernet bridges.

A considerable increase in traffic and number of connexions to the network was noted during the year: Macintosh on Ethernet and Appletalk, PC MS-DOS on Ethernet, workstations. Various initiatives have been taken to handle this traffic:

- installation of a network monitoring and alarm station for DECNET and TCP/IP: the development is still in progress,
- installation of a bridge/router between ESRF and ILL to eliminate unnecessary traffic.

Some projects are still at the design stage, in particular installation of an FDDI network ring and the modernisation of our network analyser, which is a basic tool for the maintenance and monitoring of the network.

### *External networks*

The Service has helped the Central Facilities Service in transferring the HEPNET network from the VAX 11/750 to the VAX-Station GPX. But the main activity was connecting the ILL site to the Grenoble network, GRENET: ILL was connected to the CNRS active star via ISN, a CISCO bridge/router being installed at ILL. Operations started in October for TCP/IP and in November for DECNET, with the transfer of EARN.

The Service took an active part in the setting up of GRENET as regards the DECnet protocol.

The subsequent stage is the connexion of ILL to the Internet network, this project being done in relation with the SCCT.

The increasing requirements on the networks - internal and external - by ILL staff, but also from EMBL and ESRF mean that at least one fulltime person is needed to manage the network.

### *Assistance to external centres*

The Service has provided considerable assistance to nuclear centres: HMI Berlin has had support for their VME software developments, the University of Helsinki for the diffraction program, and the CEA/CENG for the installation of their instruments DN2, DN3 and DN5. The knowledge acquired during years of computerisation of instruments is recognised by numerous centres in other countries, and there are many requests for support, particularly from Germany and France.

The year 1991 was characterised by the reactor shutdown, but despite this there has been a great deal of work by members of the instrument service in continuing projects in progress. It has not been possible to start the UNIX project, but the installation and commissioning of an Ultrix station, carried out by the service without external aid, should be noted. A considerable effort has also been made as regards knowledge of the TCP/IP protocol, which will be very useful for the future.

### **Nuclear Physics and Special Instruments Group (NUPSI)**

The year 1991 may be divided into two distinct parts.

– From January until the end of May

Evaluation of existing instruments and functional maintenance. Change of computers ( $\mu$ VAXII) and introduction of graphics aids, also with the assistance of the Central Facilities Service graphics group.

On PN1 development of the acquisition system with ATARI and HPVectra.

On BILL new  $\mu$ VAXII.

On GAMS connection of GAMS4 and study for the project GAMS5.

On PN4 : stabilisation

All the "S" instruments are in their operational state, including the MAMBO project (Mampe bottle).

– From June to December

Dismantling of some instruments. Certain instruments are to be transferred completely to other sites.

This includes BILL, which moves from level D to the PN7 area, and is to operate with sources from the end of December 1991.

This also applies to the GAMS instruments (2/3/4) moved from level C to the end of guide hall ILL22 in place of the German part of  $N\bar{N}$ .

Installation of GAMS as a basis for Super Gams (modernisation programme).

Definition of PN7 to work with a laser (alignment tests).

For the coming year it must be assumed that the majority of Nuclear Physics instruments will operate essentially with  $\gamma$ - sources and the major work will be displacement and refurbishment.

For the "S" instruments, we have already started renewal of the electronics and acquisition system : this includes S21, S20, S34 and EVA.

Only the instruments on level D are still awaiting a decision as to whether they are to be completely dismantled and stored away for better times.

As regards the photomultiplier project, this has scarcely been affected by the present situation, and it is following its normal course, which should lead in February/March 1992 to tests with  $\gamma$ - rays, followed by neutrons, initially at LAPP in Annecy, and subsequently at Risø (Denmark).

### **Data and Projects Group**

The activities of the Group were confined to three domains this year. The organisation of the workshop on data treatment for small-angle scattering and neutron reflectivity data was successfully promoted by the Group, and attracted 67 participants to the ILL. Apart from providing invaluable secretarial support many members of the Computing Department generously assisted in the technical aspects offering dextrous aid and equipment loans to create a local computing centre for the practical sessions.

Development of programming aids continued with installation of a major update to a commercial graphical data manipulation package acquired initially last year. This now offers compatibility with industry standard X11 graphics protocols, and hence permits operations amongst heterogeneous systems. Motif software was acquired for one of the Group's workstations and is serving as a basis for further work on user interface design using standard components.

Simulations of use of parallel processing for data treatment in acquisition systems advanced satisfactorily. The specification of a transputer controlled front-end electronics to link this analysis system to a detector was developed in collaboration with the Rutherford Appleton Laboratory, who are at present undertaking its manufacture.

The demands of achieving expertise in UNIX systems commensurate with that already gained in proprietary systems have become the dominant activity of the Group at present.

## Reactor Operation 1991

The reactor operating schedule, initially planned for 5.5 cycles in 1991, was interrupted on 30 March 1991 after 1.5 cycles of operation. On 5 April 1991, during an internal examination of the reactor as part of a routine inspection, unusual marks were observed in the central part of the upper anti-turbulence grid. Subsequent examinations showed that these marks were cracks incompatible with the continuation of normal reactor operation in its current state.

Different solutions for the refurbishment of the reactor are currently being studied, and preliminary dismantling work is in progress.

### Cycle 5/90 (part 2)

Operation from 8 January to 1 February 1991.

The reactor was deliberately shut down from 18 January at 0h45 until 20 January at 8h30, following a bomb alert; in compensation the cycle was extended by 2 days.

Apart from this interruption, the cycle was completed without incident.

### Cycle 1/91

Operation from 12 February to 30 March 1991; the scheduled dates were respected. A brief reactor shutdown on 1 March was caused by a cut in the EDF power supply.

## Data for 1991

Number of days originally scheduled	254
Actual number of days of operation	68
Number of equivalent days of full power	67.8
Actual operating time as proportion of year (%)	18.6
Actual operating time in relation to time scheduled (%)	26.7
Number of unscheduled shutdowns	2
Number of fuel elements used	1.5
Number of new elements received	6
Number of fuel elements despatched (storage at Cadarache)	8

Operations preparatory to the refurbishment of the reactor:

The aim of the dismantling work done during the second half of 1991 was to permit access to the reactor vessel, an essential preliminary whatever solution is adopted for the reactor refurbishment.

The main operations currently effected cover:

- removal of all the heavy water and physical separation between the heavy water and the reactor vessel,
- drying of the reactor vessel, which was then filled with light water,
- dismantling the experimental instruments and the associated shielding to permit access to the thimbles of the beam tubes to be removed,
- dismantling of the internal parts of the reactor vessel, in particular:

- safety rods,
- control rods,
- cold sources,
- hot source,
- fuel element seating,
- reactor vessel chimney,
- natural convection and anti-siphonage valves,
- reactor valve,
- pneumatic tubes,
- source support tube, etc,
- integrated instruments: 'canal B', UCN loop, PN 3/4, H6/H7,
- flux measurement chambers and associated supports.

Preparation of tooling for intervention work on the reactor vessel and for cutting up the various radioactive parts to be dismantled (see photographs on pages 87 and 88).

### Studies in progress

In parallel to the work preparatory to intervention on the reactor block, working groups have been set up with the following terms of reference:

- analysis of the present situation of the elements concerned,
- study of the life-time of the various parts comprising the reactor block,
- drawing-up an action plan to resolve the present difficulties and to envisage operation of the reactor over a further period of 15 to 20 years.

- FINANCE p. 122
- PERSONNEL AND HUMAN RESOURCES p. 124

## Finance

### Implementation of the 1991 Budget

The reactor shutdown since April 1991 and the preparations for its refurbishment have been the most important factors influencing this year's Budget. The Budget authorized for 1991 amounted to a total of 312.656 MF excl. taxes. Total expenditure in 1991 is estimated at 299.136 MF. The difference of 13.520 MF represents the savings realized following the reactor shutdown. These savings are to be used as a provision to help finance the modernization of the reactor.

The following tables show the changes in expenditure and income between 1990 and 1991:

#### Comparison of 1990 and 1991 Budgets (Expenditure)

Expenditure	Expenditure 1990		Estimated Expenditure 1991		Change %
	MF	%	MF	%	
<b>1. Staff costs</b>	174.157	60.1	177.957	59.5	+ 2.2
<b>2. Fuel elements</b>	22.350	7.7	36.200	12.1	+ 62.0
Consumables	26.159	9.0	23.195	7.8	-11.4
Long term supplies and services	8.083	2.8	10.589	3.5	+ 31.0
Short term supplies and services	13.016	4.5	11.756	3.9	- 9.7
Travel	2.574	0.9	2.225	0.7	- 13.6
Miscellaneous adm. costs	8.498	3.0	5.180	1.7	- 39.0
Taxes and fees	1.462	0.5	1.532	0.5	+ 4.8
<b>3. Operation</b>	59.792	20.7	54.477	18.2	- 8.9
<b>Total Operation</b>	<b>256.299</b>	<b>88.5</b>	<b>268.634</b>	<b>89.8</b>	<b>+ 4.8</b>
Buildings	0.205	0.1	2.284	0.8	n.c.
Equipment	7.152	2.5	6.127	2.0	- 1.43
Instruments	16.572	5.7	13.230	4.4	-20.2
Other investments	9.279	3.2	8.861	3.0	- 4.5
<b>Total Investments</b>	<b>33.208</b>	<b>11.5</b>	<b>30.502</b>	<b>10.2</b>	<b>- 8.4</b>
<b>Total Expenditure</b>	<b>289 507</b>	<b>100.0</b>	<b>299.136</b>	<b>100.0</b>	<b>+ 3.3</b>

#### Comparison of 1990 and 1991 Budgets

Income	Income 1990		Estimated Income 1991		Change %
	MF	%	MF	%	
Collaboration with ESRF	1.202	0.4	1.435	0.4	+ 19.4
ILL's own income	10.581	3.6	7.430	2.4	- 29.8
Spanish, Swiss, Austrian contributions	13.487	4.7	13.689	4.4	+ 1.5
Associates' contributions	278.203	96.1	281.672	90.1	+ 1.2
Carry forward 1990 to 1991	- 14.370*	- 5.0	8.430	2.7	-
Carry forward 1991 to 1992			- 13.520**	-	-
Use reserve account	0.500	0.0	-	-	-
Miscellaneous	- 0.096	0.2			-
<b>Total Income</b>	<b>289 507</b>	<b>100.0</b>	<b>299.136</b>	<b>100.0</b>	<b>+ 3.3</b>

\* Of this amount 5.94 MF were put in the reserve account and 8.43 MF carried forward to 1991.

\*\* Provision for refurbishment of reactor.

The comparison between expenditure in 1990 and 1991 shows an increase in staff costs of 2.2 %, which is essentially due to general salary increases; this increase has been partly compensated by the first effects of the personnel policy introduced after the reactor shutdown (cf. below: "Personnel and Human Resources").

The large increase (+ 62 %) in expenditure on fuel elements results from the postponement to 1991 of the delivery of 57.4 kg Uranium, and the payment for 69 kg Uranium to be delivered in Spring 1992. The stock of new fuel elements amounts to 8 at the end of 1991 (production of new elements has been reduced to 1 element per year from 1992 to 1994). As the Savannah River (USA) reprocessing plant no longer accepts used fuel elements, we have found an interim storage site for our used fuel elements at Cadarache (CEA).

The other operation expenditure is down by almost 9 %, in particular because of the reduction in consumption of electricity and cryogenic fluids, and in travel costs for guest scientists following the reactor shutdown.

Investments decreased by 8.4 %. In the scientific sector the construction of the new instruments for the horizontal cold source (IN10 C, IN15, D22) was, however, continued as planned without reductions. The figure for investments for buildings (2.284 MF) concerns a payment for the joint ILL/ESRF building which will be completed in 1992 (library, theoreticians' offices, restaurant and cafeteria).

## Forward look

At its meeting on 28 November 1991, the Steering Committee adopted a Budget with expenditure of 310 MF, requesting the Management to set up a reserve of 75 MF within this figure, to finance the start of the Reactor Modernization Programme, planned for 1992, 1993 and the beginning of 1994. As a result the Normal Budget for 1992 is 235 MF, which implies major savings in all categories of expenditure.

## Purchasing

Early in the year, two important contracts for the fuel cycle were negotiated. NUKEM (D) were awarded a contract for the supply of 69 kg of uranium metal (93% enriched). In April, CERCA (F) were awarded a contract for the production of 12 fuel elements intended for reactor operation during 1992 - 1994. However, after the decision taken in July to shut down the reactor, manufacture of the fuel elements had to be re-scheduled so that in 1992, 1993 and 1994 production will be reduced to one element per year (essentially to maintain CERCA's technical capacity).

Apart from the fuel cycle, the highest value purchase in 1991 involves the manufacture and supply of the neutron guides H1 - H2 which are to be replaced in 1993. The raw glass for the in-pile part has already been ordered from CORNING (F), whereas SCHOTT (D) will supply the boron glass for the out of pile parts. At the time of writing, we are studying the offer received from NEUTRONS INSTRUMENTATION (F) for the fabrication and installation of these neutrons guides.

In the first half of the year, a number of important orders were placed for the instruments. Notably, for the D20 detector, TECHNITRON (USA) received the order for the MIZAR VME cards; WIENER (D) will supply the VME racks, and CREATIVE ELECTRONICS (CH) the VME bus. Other significant purchases for the instruments were :

- the programmable controller and software for D22 from AMS (F),
- the analyser supports for IN 10 C from BERNASCONI (F),
- the analyser coil for IN 11 C from SPECIALTEKNIK (Sweden),
- and the detector housing for D1A, also from BERNASCONI (F).

The decision to shut down the reactor and the need to find economies to finance its refurbishment greatly affected the purchasing activity in the second half of the year. Soon after this decision, a total freeze on spending was enforced in order to re-adjust the budget for 1991. A new lower tariff was negotiated with the electricity corporation (EDF) in view of the lower capacity required over the next few years. The eventual purchase of Diesel back-up generators for peak days has been postponed.

As a consequence of the reactor shutdown all maintenance contracts for computers on instruments were cancelled; this will allow significant savings in 1992 and 1993. During this period the Institut plans to convert all its scientific computing applications which currently run on VMS to the UNIX operating system. In the safety area, a number of new audible radiation detectors were purchased from MERLIN GERIN (F) and, negotiations are in progress for the supply of new interlocking safety devices.

A group of industrial experts from the three member states, consisting of nuclear engineers from TECHNICATOME (F), SIEMENS (D) and AEA TECHNOLOGY (GB) were commissioned to examine the options for replacement of the faulty grids. At the time of writing, we are negotiating a contract with the same group of industrial companies led by TECHNICATOME (F), who will study in detail the preferred option for refurbishment of the reactor, that is, complete replacement of the reflector tank. This study was requested by the Associates at their meeting on October 28 and 29 and must be completed by 1st of February 1992 with reliable financial estimates based on commitments from industrial companies.

Considerable savings were achieved by competitive tendering for major purchases as well as by negotiating discounts with regular suppliers. Economies were made by cancelling or reducing the scope of certain maintenance contracts (see above) which represent a large slice of ILL's expenditure. In certain cases purchases have been postponed in order to achieve the economies required to finance the refurbishment of the reactor.

Whenever possible an international call for tenders was carried out for major purchases : offers were compared on an ex-works basis so as not to disadvantage British, German, Swiss, Spanish and Austrian firms compared with local suppliers. The distribution of ILL purchases (orders exceeding 50 KF) in the first 10 months of 1991 is shown in the diagram. The figure includes purchases for which a free choice of suppliers was possible excluding therefore the fuel cycle, electricity and small purchases less than 50 KF.

**Distribution of ILL purchases (orders > 50 KF)**

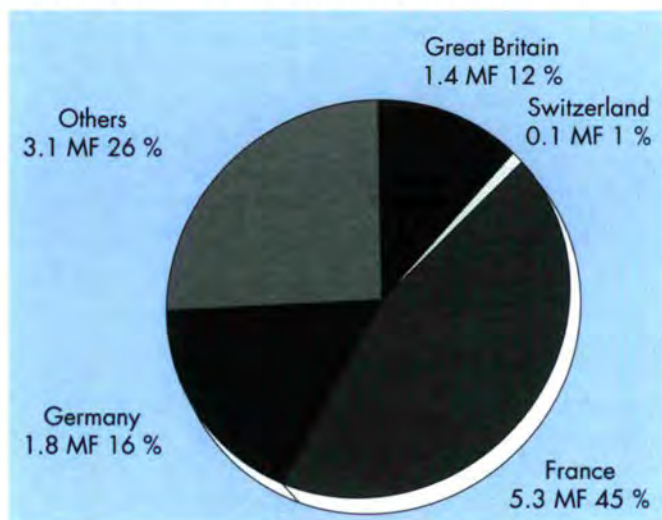

**Stores**

The joint ESRF/ ILL stores facility continues to operate successfully allowing economies for both partners. All deliveries of purchased equipment were received and checked quantitatively by the storemen who at the same time arranged the despatch of samples, returned equipment, etc. and the provision of raw materials.

**Personnel and Human Resources**

With effect from 1 October 1991 the Personnel and "Relations Sociales" groups were combined to form the Personnel and Human Resources Group (SPRH). The essential idea of this reorganisation is to provide optimum cover for all questions connected with recruitment, reception, career planning and training of staff.

The new service comprises:

- A "Human Resources Management" Group, dealing with training, recruitment, career management, studentship periods, contracts of employment and problems associated with the integration of personnel (in particular schools and language courses, reprographics).

- A "Personnel Management" Group, responsible for salaries, travel, general personnel matters (retirement, pensions, insurance, housing fund, canteen and cafeteria, "Mutuelle" and Social Security).

- Service Groups:

- Drivers + Mail
- Reception
- Accommodation (looking for and management of flats).

- The Welfare Assistant, whose functions are defined by the legislation.

**Management of Human Resources**

**Training Programme for ILL Staff**

The training programme corresponds to that proportion of salaries allocated by law to expenditure on training for ILL staff (1.2 % of the total payroll in 1991). In this context ILL organises courses particularly to assist personnel in their career. These courses are grouped in two main areas: languages and "technical" subjects. The language courses (French, English, German and Spanish) represent approximately 30 % of the applications. Technical courses cover all the technological and computing fields, etc.

Training is seen as a real investment both for the individual and for the employer. The staff want to improve their professional skills, which is reflected in an increase in applications to keep up with technological developments, particularly in the computing field. These requests also express the desire to do better, for example by attending courses such as "understanding the different aspects of quality". More than 200 persons attended training courses in 1991.

**Staff**

At 31.12.91 there was a total of 469 staff on posts, which means a reduction of 14 staff members in comparison with the end of 1990 (483). This reduction is the first effect of a new personnel policy introduced after the extended shutdown of the reactor was confirmed in the middle of 1991. This policy comprises various aspects, including

- no new recruitment, apart from really exceptional cases decided by the Directors
- retirement from the age of 60, as provided for in the ILL Collective Agreement
- encouragement of mobility (e.g. detachment, secondment, unpaid leave).

As a result of these measures it is expected that total staff will be between 430 and 435 by the end of 1992.

There have only been minor changes in the breakdown by nationalities at the end of 1991 in relation to the previous year:

• French	:	61.6 % instead of 61.9 %
• German	:	17.5 % instead of 16.6 %
• British	:	15.1 % unchanged
• Others	:	5.8 % instead of 6.4 %.

The table below shows the changes in 1991. All the recruitments and new contracts of employment were done in the first half of 1991, before the programme of economies was introduced.



## Integration of personnel

### French Courses

ILL has made its French courses a significant element of its policy for integrating employees and their families. Learning French not only permits rapid adaptation to the professional context, but also to a new way of life. These courses are accordingly open to ILL staff, long term visiting scientists and their partners. During the academic year 1990/91, 103 pupils attended 6 groups at different levels and an intensive grammar class. The ILL is recognised as a training organisation for French as foreign language, and can accept pupils from the adjacent laboratories.

The participation of ESRF staff is at present increasing significantly.

### International Education

Grenoble has established international education at different levels. In September 1991 more than 800 children were attending the international sections:

– 420 at the Lycée International Stendhal (upper secondary school)

– 320 at the Collège International Stendhal (lower secondary school)

– 73 at the Houille Blanche International Primary School.

ILL has been very active in developing international schooling and is continuing to follow its development with great interest and in close collaboration with ESRF.

### Career Management

On 1 July 1991 the Director signed with the CFDT, FO and SA-ILL unions a protocol to the ILL Collective Agreement on the scale of qualifications and salaries for “non-cadre” staff. This agreement constitutes a major step towards better management of the careers of “non-cadres” and a simplification of the ILL’s salary system.

## Personnel Management

### Salaries

A salary agreement signed on 21 May 1991 by the Director and the SA-ILL union provided for the following general increases for 1991: 1.4 % at 1.4.91 and 1.4 % at 1.11.91. A meeting between the signatories is planned for the beginning of 1992, to review the application of this agreement in the light of the general economic developments and of the ILL.

### Shift work

By an agreement signed on 12.3.91, the Management and the CFDT, FO, CGT and SA-ILL unions introduced regulations covering the work of staff on shift work at ILL.

### Guest scientists

The number of visits in 1991 was about 500 (350 persons). The great majority of these visits was during the first four months of the year.

### ESRF/ILL restaurant and cafeteria

The ESRF and ILL Managements have signed a contract on the financing, construction and use of a joint building to contain (apart from the joint library and theory group) the future joint restaurant and a cafeteria, due to start operation in mid-1992. A commission consisting of representatives of ESRF and ILL is examining the different offers with a view to choosing the sub-contractor who will provide these services.

– SEMINARS	P.128
– CONFERENCE CONTRIBUTIONS	P.133
– WORKSHOPS ORGANIZED BY ILL IN 1991	P.143
– THESES	P.144
– PUBLICATIONS - INTERNAL REPORTS	P.145
– AUTHOR INDEX	P.180
– PAPERS ACCEPTED FOR PUBLICATION	P.194

## SEMINARS

## College 2

## Theory

“What can we learn by studying heavily doped cuprates”.  
D.I. KHOMSKII, Lebedev Physics Institute, Moscow, USSR.

“Flow-induced 1st order transition of the aggregation in a lattice gas”.  
M. UWABA, ILL, Grenoble, France.

“Optical, magnetic and single-particle excitations in the multi-band Hubbard model for cuprate superconductors”.  
W. HANKE, Universität Würzburg, Germany.

“An exactly solvable model of interacting electrons”.  
M. RASETTI, Polytechnico, Torino, Italy.

“Exotic phases in Heisenberg spin models”.  
A. PIPINELLI, DRF, CEN, Grenoble, France.

“Charge motion in doped Mott insulators”.  
J. WHEATLEY, Superconductivity Research Center, Cambridge, U.K.

“Quantum spin fluctuations and spatial disorder in antiferromagnets with infinitely degenerate ground states”.  
E.F. SHENDER, ILL and Leningrad, USSR.

“Parois de domaines dans les systèmes dynamiques : brisure de symétrie et mise en mouvement”.  
M. LAJZEROWICZ, Lab. de Spectrométrie Physique, Université Joseph Fourier, Grenoble, France.

“Superconductor-insulator transition in disordered thin films”.  
P. YOUNG, University of California, Santa Cruz, USA.

“Structure and dynamics of metal surfaces”.  
K.P. BOHNEN, Institut für Nukleare Festkörperphysik, Kernforschungszentrum, Karlsruhe, Germany.

“Charges and vortices in Josephson arrays”.  
G. SCHÖN, Delft University of Technology, The Netherlands.

“Antiferromagnetic fluctuations and neutron scattering for high  $T_c$  systems”.  
S. MALEEV, CENG and Leningrad, USSR.

“Holes in antiferromagnets : spin 1/2 versus the classical limit”.  
M. GUNN, University of Birmingham, U.K.

“Analyse en déphasage des courants persistants dans les métaux normaux”.  
E. AKKERMANS, Technion Israël Inst. of Technology, Haifa et CNRS, Grenoble, France.

“Peut-on ‘entendre’ l’énergie libre d’un colloïde ?”  
B. DUPLANTIER, Physique Théorique, CEN Saclay, France

“Statistics of the mesoscopic fluctuations and the Anderson localization problem”.

I.V. LERNER, Max Planck Institut für Kernphysik, Heidelberg, Germany.

“Polarons and excitons in the charge transfer model of high  $T_c$  superconductors”.  
J. LORENZANA, Sissa, Trieste, Italy.

“Weak localization” in quantum tunnelling”.  
G.W. FORD, ILL and University of Michigan, USA.

“Vesicle membranes of polymerizable diacetyl phospholipids”.  
M. MUTZ, ENS, Paris, France.

“Effet Kondo à plusieurs canaux : solution complète avec théorie des champs conforme”.  
A. LUDWIG, Simon Frazer University, Vancouver, Canada.

“Mass anisotropy and stability of the heavy Fermi liquid”.  
R. JOYNT, University of Wisconsin, Madison, USA.

“Self assembly of liquid vesicles”.  
T. MAGGS, Chimie, ESPCI, Paris, France.

“Magnetoresistance anisotropy near the SDW transition of quasi 1-d conductors”.  
K. MAKI, University of Southern California, Los Angeles, USA.

“Helical solutions for XY spins”.  
W.M. SASLOW, Texas A & M University, USA.

“Electrons and electron-lattice coupling in Buckminsterfullerene”.  
G. STOLLHOF, Max Planck Institut, Stuttgart, Germany.

“Spin singlet quantum hall effect and charge-spin separation on the edge”.  
A. BALATSCY, Urbana Champaign, USA.

“Spin currents in superfluid  $^3\text{He}$ ”.  
I. FOMIN, Landau Institute, Moscow, USSR.

“A kinetic mechanism for magnetic ordering”.  
A. OVCHINIKOV, Inst. of Chemical Physics, USSR Academy of Sciences, Moscow, USSR.

“Weak crystallization theory”.  
E. KATS, Landau Institute, Moscow, USSR.

“Premelting phenomena in small grains”.  
G. DEUTSCHER, Université de Tel Aviv, Israel, and CRTBT, CNRS, Grenoble, France.

“Informal discussion of new results in Fermi liquid theory”.  
G.E. VOLOVIK, Landau Inst. of Theoretical Physics, Moscow, USSR.

“Different structures and kinetics during stationary solidification of a supercooled pure melt”.  
D.E. TEMKIN, I.P. Bardin Institute of Ferrous Metals, Moscow, USSR.

“Anderson localisation: scattering theory, scaling and solutions”.  
J. CHALKER, ILL, Grenoble, France.

“New insight into nucleation of vortices in quantum liquids: the case of thin films of  $^3\text{He-A}$ ”.

N.N. KOPNIN, Landau Institute, Moscow, USSR.

“First order phase transition in the modified X-Y model”.

A. HÜLLER, Institut für Theoretische Physik, Erlangen, Germany.

“Competition between Kondo effect and magnetic interaction: variational study of the two impurity Anderson model”.

L.C. ANDREANI, IRRMA, Lausanne Switzerland.

“Rayleigh-Ritz variational procedure for the calculation of two body correlations”.

D. JANSSEN, ILL, Grenoble, France.

“Microwave response of unpinned superconductors vortex cores at very low temperatures”.

T. HSU, CRTBT, CNRS, Grenoble, France.

“Hole dynamics in semiconductor heterostructures”.

A. FASOLINO, ESRF and SISSA, Trieste, Italy.

“Core level spectroscopy as a probe of orbital magnetization”.

P. CARRA, ESRF, Grenoble, France.

“Energy of 2d-electrons in a magnetic field”.

A.S. ALEXANDROV, Moscow Engineering Physics Institute, USSR.

“Problèmes de surfaces aléatoires, matière condensée et théorie des cordes”.

E. BREZIN, ENS, Paris, France.

“What kind of liquids are the high temperature superconductors ?”

K. BEDELL, Los Alamos National Laboratory, USA.

“Properties of Fermi liquids with a finite range interaction”.

P. NOZIERES, ILL, Grenoble, France.

“Polymerized membranes with two body interactions”.

E. GUITTER, SPHT, Saclay, France.

“Quasielectrons in the t-J model as bound states of spinons and holons”.

D. FÖRSTER, Max Planck Institut, Stuttgart, Germany.

### College 3

#### Fundamental and nuclear physics

“Physics with low energy positrons”.

M. CHARLTON, University College, London, U.K.

“Antiproton induced fission of normal and hypernuclei: a new probe of nuclear dynamics”.

F. MALEK and H. NIFENECKER, ISN, Grenoble, France.

“Optical  $\alpha$ -nucleus potentials. Applications in nuclear structure, transfer reactions and nuclear astrophysics”.

F. HOYLER, University of Tübingen, Germany.

“Current results and future prospects for neutron lifetime determinations”.

S. DEWEY, Nat. Inst. of Standards and Technology, Washington, USA.

“Determining the speed of light with GAMS 2, 3 and 4, or does  $E = mc^2$  ?”

G. GREENE, Nat. Inst. of Standards and Technology, Washington, USA.

“On the way to a dense  $^3\text{He}$  target as a neutron spin filter”.

E. OTTEN, Universität Mainz, Germany.

“One and two phonon octupole states in nuclei around  $^{146}\text{Gd}$ ”.

P. KLEINHEINZ, Forschungszentrum, Jülich, Germany.

“Regular and chaotic features of nuclear collective dynamics”.

V.G. ZELEVINSKI, Institute of Nuclear Physics, Novosibirsk, USSR.

“Cascade: a detector for the elemental analysis of high energetic cosmic rays”.

H.J. GILS, Kernforschungszentrum, Karlsruhe, Germany.

“New measurements on neutron beta decay at LNPI”.

A.P. SEREBROV, LNPI, Gatchina, Leningrad, USSR.

“Low spin states of  $^{111,113}\text{Cd}$ ”.

Z. NEMETH, Kernforschungszentrum, Karlsruhe, Germany

“Exotic beam production and acceleration”.

H. NIFENECKER, ISN, Grenoble, France.

“Studies of energy loss of heavy atoms by means of the linearized Boltzmann equation”.

D. JANSSEN, ILL, Grenoble, France.

“Karmen: Neutrino physics between 5 and 50 MeV”.

R. MASCHUW, Kernforschungszentrum, Karlsruhe, Germany.

“Determination of interatomic potentials at energies between 5-350 eV”.

J. KEINONEN, University of Helsinki, Finland.

“Search of time reversal violation in the decay of polarized  $^8\text{Li}$ ”.

J. SROMICKI, ETH, Zürich, Switzerland.

“Molecular dynamics simulation of atom-atom collisional scattering at low energy”.

A. KURONEN, University of Helsinki, Finland.

“Search for mixed symmetry states”

T. OTSUKA, University of Tokyo, Japan.

“Study in surface physics utilizing the Doppler broadening of nuclear levels”.

R. MOREH, Ben-Gurion University, Beer-Sheva, Israel.

“Search for a 17 keV neutrino”.

K. SCHRECKENBACH, TU München, Germany.

“New neutron lifetime results on the neutron  $\beta$ -decay”.

L. BONDARENKO, Kurchatov Institute, Moscow, USSR.

"Today's situation at the unit 4 of the Chernobyl nuclear power plants".

A. MOROZOV, Kurchatov Institute, Moscow, USSR.

"Weak interactions in hadrons".

M. CLAUSNITZER, Universität Giessen, Germany.

"Some aspects of UCN optics".

A.I. FRANK, Kurchatov Institute, Moscow, USSR.

"Nuclei far from stability".

C. GROSS, University Göttingen, Germany.

## College 4

### Structural and magnetic excitations

"Electron-phonon interaction in niobium".

A. BOOTHROYD, University of Warwick, U.K.

"Small angle neutron scattering near the superconducting phase transition".

N. BERNHOEFT, Durham University, U.K.

"Prospects for the development of superconductive thin films and devices".

G.W. MORRIS, University of Cambridge, U.K.

"The vibrating fibre microbalance : a technique for studying layer-by-layer adsorption on graphite".

G. TORZO, University of Padova, Italy.

"Spin, exchange and anisotropy in the covalent-chain antiferromagnet  $\text{TlFeS}_2$ ".

D. WELZ, Bochum, Germany.

"Antireflecting sublayers for neutron thin film polarizing mirrors".

V.V. PASYUK, JINR, Dubna, USSR.

"Critical scattering and short-range order in beta-brass - a general scaling law".

W. SCHWEIKA, Institut für Festkörperforschung, Jülich, Germany.

"Brillouin scattering from fluids".

P. VERKERK, Inter-University Reactor Service, Delft, The Netherlands.

"Excitations in a spin 1/2 Heisenberg antiferromagnet chain".

S. NAGLER, University of Florida, USA.

"Recent investigations into the nature of the critical phase transition of a 2-D ferromagnet".

S. BRAMWELL, ILL, Grenoble, France.

"The diffusion of optical phonons in imperfect crystals and the problem of the central peak".

B.P. TOPERVERG, Leningrad Nuclear Physics Institute, USSR.

"Local moment to heavy fermion cross-over in  $\text{CeRu}_2\text{Si}_{2-x}\text{Ge}_x$  alloys".

B. RAINFORD, University of Southampton, U.K.

"Tunnelling and IR spectroscopy of the superconducting gap in bismuth superconducting oxide high  $T_C$  materials".

L. FORRO, IGA, EPF, Lausanne, Switzerland.

"Fe spins fluctuations in  $\text{YBa}_2(\text{Cu}_{1-x}\text{Fe}_x)_3\text{O}_7$ , probe of the Cu states ?"

M. HENNION, CEA, Saclay, France.

"Neutron specular reflection studies on superconducting, magnetic and absorbing thin films on the polarized neutron spectrometer at the IBR-2 reactor".

V.V. PASYUK, JINR, Dubna, USSR.

"MARI - the first year of operations".

S. BENNINGTON, ISIS, Rutherford Laboratory, U.K.

"High energy magnetic excitations in  $\text{La}_2\text{CuO}_4$  measured on a spallation neutron source".

S. HAYDEN, University of Bristol, U.K.

"The exact thermodynamics and heterophase fluctuations of first-order displacive structural phase transitions".

R. GOODING, Queen's University, Kingston, Ontario, Canada.

"Theory and modelling of martensitic transformations".

P.-A. LINDGÅRD, Risø National Laboratory, Denmark.

"Uncovering the Lord Rayleigh Laboratories - a glimpse of an epoch in 19th Century Physics". (ILL/ESRF seminar).

H.M. ROSENBERG, Clarendon Laboratory, Oxford, U.K.

"Studies of low dimensional magnetic systems using neutron reflection".

R. BATESON, ILL, Grenoble, France.

"Competition between crystal fields and kondo effects in heavy fermion systems".

K. MATHO, CRTBT, CNRS, Grenoble, France.

"High momentum transfer neutron scattering from liquid  $^4\text{He}$ ".

K. ANDERSEN, ILL, Grenoble, France.

## College 5

### Crystallographic and magnetic structures

"The role of the slope of the physical space as order parameter in quasicrystal-crystal phase transitions".

M. TORRES, Centro de Física Aplicada, Madrid, Spain.

"Technique and applications of scanning tunneling microscopy and force microscopy".

J. HEIL, Physikalisches Institut, Frankfurt, Germany.

"Structural studies of perovskites containing pentavalent cations".

P.D. BATTLE, Inorganic Chemistry Laboratory, Oxford, U.K.

"The chemical bond in inorganic solids".

I.D. BROWN, Inst. for Materials Research, Hamilton, Ontario, Canada.

“Time-of-flight diffraction at stationary neutron sources”.  
P. HIISMÄKI, Technical Research Centre of Finland,  
Helsinki.

“Spin-slips and the magnetic structures of holmium”.  
R.A. COWLEY, Clarendon Laboratory, Oxford, U.K.

“New possibilities in diffraction: high energy photons  
from synchrotron radiation”.  
J.R. SCHNEIDER, Hasylab, Hambourg, Germany.

“Recent  $\mu$ SR results on magnetic properties of cuprate  
materials”.  
E.J. ANSALDO, Saskatoon, Canada.

“Thermodynamical properties of incommensurate  
magnetic systems”.  
D. SCHMITT, Lab. Louis Néel, CNRS, Grenoble, France.

“Monte Carlo simulations of the dynamics of highly  
excited phonons”.  
J. WESNER, Johann Wolfgang Goethe Universität,  
Frankfurt, Germany.

“Electron density distributions of simple substances  
obtained from X-ray powder data by the maximum entropy  
method”.  
M. TAKATA, Dept. of Applied Physics, Nagoya University,  
Japan.

“Control and prediction of crystal structure for organic  
compounds. State of the art and perspectives”.  
A. GAVEZOTTI, Dept. of Physical Chemistry, Milano,  
Italy.

“Molecular motion in crystals: interpretation of  
anisotropic displacement parameters (ADP's)”.  
H.-B. BUERGI, Institut für Mineralogie und  
Kristallographie, Bern, Switzerland.

“Structural analysis of monolayers using specular  
reflection and grazing incidence diffraction”.  
C. KENNARD, University of Queensland, Australia.

“A diffraction method for the detection of weak disorder  
in crystals”.  
W. KUHS, University of Karlsruhe, Germany.

“Toward a  $^3\text{He}$  neutron polarization filter: recent  
progress at Mainz with the mechanical compression of  
polarized gas”.  
W. HEIL, Institut für Physik, Universität Mainz, Germany.

## College 6

### Liquids, disordered materials

“Surface phase transition and kinetics of  $\text{Cu}_3\text{Au}$  (111)”.  
H. ZABEL, Universität Bochum, Germany.

“Hydrogen potential in  $\beta\text{-V}_2\text{H}$  studied by deep inelastic  
neutron scattering”.  
R. HEMPELMANN, Institut für Festkörperforschung,  
Forschungszentrum Jülich, Germany.

“Inelastic neutron scattering at small angles in argon at  
low and intermediate densities”.  
P. VERKERK, TU Delft, The Netherlands.

“Tunnelling states and soft localized vibrations in glasses”.  
H.R. SCHOBER, KFA Jülich, Germany.

“Atomic scale simulations of the anomalous diffusion in  $\beta\text{-Zr}$ ”.  
F. WILLAIME, CEN, Saclay, France.

“Water, as revealed through its influence on the  
structural slowing down and the vitreous transition in  
concentrated aqueous electrolytes”.  
J. DUPUY-PHILON, Université Claude Bernard, Lyon,  
France.

“Disorder, localized relaxations and tunnelling in solids”.  
G. JOHARI, McMaster University, Hamilton, Ontario,  
Canada.

“On the mode coupling approach for the glass-transition”.  
J. WUTTKE, ILL, Grenoble, France.

“Self-diffusion and phonons in bcc metals”.  
J. TRAMPENAU, ILL, Grenoble, France.

“Phonons and rotons in liquid  $^4\text{He}$  - a new interpretation”.  
H.R. GLYDE, University of Alberta, Canada.

“Design, preparation and properties of a molecular wire”.  
L. ZUPPIROLI, EPF, Lausanne, Switzerland.

“Optical sensitization and new photoelectric properties  
of ferroelectric polymers”.  
V.M. FRIDKIN, Institute of Crystallography, Academy of  
Sciences of the USSR, Moscow, USSR.

“ $\alpha$ -relaxation in polymers - a study by neutron scattering  
and relaxation techniques”.  
J. COLMENERO, Universidad del País Vasco,  
San Sebastian, Spain.

“The glass transition: a standard second order transition  
with large dynamic exponents?”  
J. SOULETIE, CRTBT, CNRS, Grenoble, France.

“The structure and dynamics of  $\text{C}_{60}$ ”.  
J.R.D. COPLEY, NIST, Maryland, USA.

## College 8

### Biology

“Mapping of the human genome”.  
V. NOWOTNY, Washington University School of  
Medicine, St. Louis, USA.

“X-ray microscopy and its applications in biology”.  
R.E. BURGE, King's College, London, U.K.

“Crystallization of basic proteins with new crystallizing  
agents”.  
A. DUCRUIX, Gif-sur-Yvette, France.

**College 9****Chemistry**

"The latent symmetry approach to vibrational spectroscopy near the Brillouin zone centre".

U.A. JAYASOORIYA, School of Chemical Sciences, University of East Anglia, Norwich, U.K.

"Some recent developments in time-of-flight data analysis".

A. STUNAU, PTB, Braunschweig, Germany.

"Equilibrium budding in the Helfrich model of lipid vesicles".

B. FOURCADE, ILL, Grenoble, France.

"Crystal and electronic structures of the cobaltocene intercalates of the host lattices  $\text{SnSe}_{2-x}\text{S}_x$  ( $x = 0, 0.3, 0.5, 1.3, 1.85, 2$ )".

D. O'HARE, Inorganic Chemistry Laboratory, University of Oxford, U.K.

"Grazing angle neutron reflectometry".

V. MIKEROV, Lebedev Physical Institute, Moscow, USSR.

"Magnetically driven methyl rotation? New developments in methyl tunnelling spectroscopy".

T. HORSEWILL, Department of Physics, University of Nottingham, U.K.

"NMR characterization of microdomains in zwitterionic polymers".

B. MEURER, Institut Charles Sadron, Strasbourg, France.

"Ferroelectric copolymers: high pressure effects".

E. AMALRIC, ILL, Grenoble, France.

"Colloids as atoms".

P.N. PUSEY, Physics Department, Edinburgh University, U.K.

"Molecular charge transfer salts: antiferromagnets, metals and superconductors".

P. DAY, ILL, Grenoble France.

"Electro-optic properties of ionic solutions".

J.H. WILLIAMS, ILL, Grenoble, France.

"Molecular spectroscopy and bayesian spectral analysis: how many lines are there?"

D. SIVIA, RAL ISIS Facility, U.K.

"Microstructural characterization of cement clinker minerals and hardening cement paste by SANS".

F. HÄUSSLER, Technische Hochschule, Leipzig, Germany.

"Optical excitation and relaxation of coordination compounds".

H.U. GÜDEL, University of Bern, Switzerland.

"Scattering by polymers at interfaces".

L. AUVRAY, Laboratoire Léon Brillouin, CEN, Saclay, France.

"Effects of gelation on spinodal decomposition kinetics in gelatin".

J. LAL, Laboratoire Léon Brillouin, CEN, Saclay, France.

"Molecular structures and chain trajectories in polymeric physical gels".

J.M. GUENET, Lab. d'Ultrasons et de Dynamique des Fluides Complexes, Université Louis Pasteur, Strasbourg, France.

**Thursday colloquium**

"Nuclear ordering in copper and silver at nano- and picokelvin temperatures".

O.V. LOUNASMAA, Low Temperature Laboratory, Helsinki University of Technology, Finland.

"Electronic excitations and optical spectra of superconductors with strong electron-phonon coupling".

E.G. MAXIMOV, Lebedev Institut Moscow, USSR.

"Solutions polyelectrolyte".

J.F. JOANNY, CNRS, Institut Charles Sadron, Strasbourg, France.

"Some new ideas about rotors".

A. GRIFFIN, University of Toronto, Canada.

" $\text{C}_{60}$  and other fullerenes: new forms of carbon".

W. KRÄTSCHMER, Max Planck Institut, Heidelberg, Germany.

"Croissance des cristaux dans les cristaux liquides thermotropes".

P. OSWALD, ENS, Lyon, France.

"Polaronic effects in high  $T_c$  superconductors: the present experimental and theoretical situation".

J. RANNINGER, CRTBT, CNRS, Grenoble, France.

**Reactor physics**

"Reactor physics of the advanced neutron source".

J.M. RYSKAMP, Idaho National Engineering Laboratory, USA.

**Thesis student seminar**

"The helical to conical phase transition in holmium: the anomalies and implications".

A. PEARCE, ILL, Grenoble, France.

"New results from nearly perfect crystals of hematite ( $\alpha\text{-Fe}_2\text{O}_3$ )".

J. SANDONIS, ILL, Grenoble, France.

## Conference contributions

### AJACCIO, France: 10ème Colloque Annuel de la Société Française de Biophysique: Acides nucléiques-chromatine. Architecture et régulation de leurs fonctions - 1991/09/21-25

EBEL C. Etude en solution du facteur d'élongation polypeptidique hEF-Tu d'une bactérie halophile extrême. (Poster)

### AMBOISE, France: 23ème Colloque INSERM: Perspectives en instrumentation et méthodologies biomédicales - 1991/01/21

ZACCAI G. Les neutrons pour l'étude des protéines. (Invited talk)

### AURIS-EN-OISANS, France: 6th Himalaya-Karakorum-Tibet Workshop - 1991/03/20-23

OLIVER R.A., PEARCE J.A., DEN WANMING. The geochemistry of 30 Ma to recent alkali magmatism on the Tibetan Plateau.

### AUSSOIS, France: European Workshop on X-ray Detectors for Synchrotron Radiation Sources - 1991/09/30 - 10/04

GELTENBORT P., OED A. Micro strip anode in noble gases: an active scintillator.

GELTENBORT P., OED A. A new feature of the micro strip anode: position sensitive by inclining the rear electrode. (Poster)

### AUSSOIS, France: Colloque WEYL VII, International Conference on Metals in Solutions - 1991/06/23-28

BLANK H., KEARLEY G.J. The effect of anion substitution in nickel hexamine salts. (Invited talk)

CHIEUX P. Introduction to the mesoscopic and microscopic structure determination of M-ND3 and M-MX mixtures by neutron scattering. (Review talk)

### AUTRANS, France: XXIst European Symposium on the Dynamical Properties of Solids - 1991/09/29 - 10/3

AYACHE C., CURRAT R., MOLINIE P. Neutron study of the soft phonon mode in the layered charge-density-wave compound NbSe<sub>2</sub>-2H. (invited paper)

BERMEJO F.J., MOMPEAN F.J., BARCIA-HERNANDEZ, MARTINEZ J.L., HOWELLS W.S. Collective excitations in a molecular glass: evidence for the coupling to low-frequency modes. (invited paper)

BOISSIEU M. DE, CURRAT R., JANOT C., GOLDMAN A., STASSIS C., BELLISSENT R., MOUDDEN A., GAYLE F. Phonon dispersion curves in icosahedral and cubic R-ALiCu phase.

CODDENS G., VACHER R., PELOUS J., FORET M., COURTENS E., HEIDEMANN A., LARTIGUE C. Influence of the microstructure on the density of states of silica aerogels. (Invited paper)

ENDERLE M., KAKURAI K., WEINFURTER H., STEINER M., DORNER B. Investigation of CsNiCl<sub>3</sub> by inelastic neutron scattering. (Poster)

KAMBA S., PETZELT J., DVORAK V., CURRAT R., LEGRAND J.F. Dynamical origin of the structural phase transition sequence in BCCD. (Poster)

LAUTER H.J. Excitations in adsorbed layers.

NEEDHAM L.M. Density of state measurements in amorphous and crystalline Se<sub>x</sub>Te<sub>1-x</sub> alloys. (Invited talk)

MUTKA H., PAYEN C., MOLINIE P., SOUBEYROUX J.L., COLOMBET P., TAYLOR A.D. Quasi-one-dimensional antiferromagnets AgVP<sub>2</sub>S<sub>6</sub> (S=1) and AgCrP<sub>2</sub>S<sub>6</sub> (S=3/2). (Poster)

SCHMID B., DORNER B., VISSER D., STEINER M. Temperature and field dependent correlations in the singlet ground state system CsFeBr<sub>3</sub>.

SUCK J.-B. Dynamics of rapidly quenched and slow cooled icosahedral alloys. (Invited talk)

SUCK J.-B., EGELSTAFF P.A., ROBINSON R., SIVIA D., TAYLOR A. Experimental determination of the dispersion of collective modes in a metallic glass. (Poster)

### BAD HONNEF, Germany: 2nd International Conference on Surface X-ray and Neutron Scattering - 1991/06/25-28

AL USTA K., DOSCH H., LIED A., PEISL J. Surface sensitive neutron scattering. (Abstract & Poster)

AL USTA K., DOSCH H., LIED A., PEISL J. Neutron diffraction under grazing incidence : recent results from the EVAnescent wave diffractometer.

### BARCELONA, Spain: Seminario sobre la Caracterización de Materiales - 1991/07

RODRIGUEZ-CARVAJAL J. Difracción de neutrones por muestras policristalinas: reactores, fuentes pulsadas, avances recientes en el análisis de datos.

### BOMBAY, India: International Conference on Neutron Scattering - 1991/01/19-25

EBEL C., KRISHNAN G., ALTEKAR W., ZACCAI G. Small angle neutron scattering for the study of the solution structures of halophilic proteins.

KNOP W., HIRAI, M., OLAH G., MEERWINCK W., SCHINK H.-J., STUHRMANN H.B., WAGNER R., WENKOW-ESSOUNI M., ZHAO J., SCHÄRPF O., CRICHTON R.R., KRUMPOLC M., NIERHAUS K.H., NIINIKOSKI T.Q. Polarised neutron scattering from dynamic polarised targets in biology. (Invited paper)

SCHÄRPF O. Thin-film devices and their role in future neutron spectroscopic investigations. (Invited talk)

**BORDEAUX-LACANAU, France: Réunion du Groupe français d'Etude des composés d'insertion - 1991/03/19-22**

PILLIERE H., GOLDMANN M., BEGUIN F. Effet de taille sur la structure des composés formés par physintercalation d'alcane dans les graphitures de césium. (Talk)

**BORDEAUX, France: Colloque national de prospective sur les systèmes moléculaires organisés - 1991/10/23-25**

CHARVOLIN J. Système d'amphiphiles. (Invited talk)

**CAEN, France: Congrès de la Société Française de Physique - 1991/09/2-6**

PETRY W. Comment les phonons permettent-ils d'expliquer la diffusion dans les métaux cubiques centrés ?

**CAMBRIDGE, UK: EUROMAT 91, 2nd European Conference on Advanced Materials and Processes - 1991/07/22-24**

ALONSO J.A., RASINES I., RODRIGUEZ-CARVAJAL J. Nuclear and magnetic structures of the ordered spinels  $\text{Co}_5\text{TeO}_8$  and  $\text{Zn}_2\text{Co}_3\text{TeO}_8$ .

**CARGESE, Italy: Workshop on Nuclear Shapes and Nuclear Structure at Low Excitation Energies - 1991/06/3-7**

JOLIE J., BÖRNER H.G. Lifetime measurements in medium heavy nuclei using the  $\gamma$ -ray induced Doppler broadening (GRID) technique.

**CASSIS, France: Réunion francophone de cristallographie des protéines - 1991/09/9-13**

PEBAY-PEYROULA E., BAUD F., COHEN-ADDAD C., ODANI S., LEHMANN M.S. La protéine hydrophobe du soja. (Poster)

**CHANTILLY, France: Colloque franco-indien sur les membranes, multicouches et monocouches - 1991/05/20-23**

CHARVOLIN J. Topology and geometry of films of amphiphiles. (Invited talk)

**CINCINNATI, USA: APS Meeting - 1991/03**

SAUVAJOL J.L., DJURÁDO D., DIANOX A.J., MAGERL A., THEOPHILOU N., FISCHER J.E. Vibrational density of states of polyacetylene: inelastic incoherent neutron scattering. (Poster)

**CRETE, Greece: 27th Europhysics Conference on Macromolecular Physics 'Applications of Scattering Methods to the Dynamics of Polymer Systems' - 1991/09/23-27**

ARBE A., ALEGRIA A., ALVAREZ F., COLMENERO J., FRICK B., Dynamics of the  $\alpha$ -relaxation in glass-forming polymeric systems. Study by neutron scattering and relaxation techniques. (Poster)

**DARMSTADT, Germany: Spring Meeting of the DPG - 1991/03**

HENTZSCHEL R., FAUST H.R., DENSCHLAG H.O.  $^{14}\text{C}$  yield in neutron induced fission of  $^{249}\text{Cf}$ . (Poster)

**DIJON, France: 7th European Meeting on Ferroelectricity - 1991/07/8-12**

BUNE A.V., FRIDKIN V.M., VEZKHOVSKAYA K.A., LEGRAND J.F., Absorption changes at the phase transition of ferroelectric copolymers doped by a cyanine dye.

DURAND D., PAPOULAR R., CURRAT R., LAMBERT M., LEGRAND J.F., MEZEI F. Study of the dynamics in the incommensurate phase of  $\text{NaNO}_2$  by neutron spin-echo technique. (Poster)

EVEN J., BERTAULT M., TOUDIC B., CAILLEAU H., FAVE J.L., SCHOTT M., MOUSSA F., CURRAT R. Dynamical study of the antiferroelectric transition in a polymer crystal: pTS-D. (Poster)

**EDINBURGH, UK: International Conference on Magnetism - 1991/09/2-6**

BALLOU R., GAYDUKOVA I.Y., MARKOSYAN A.S., OULADDIAF B. Study of the Mn-moment instability in the  $\text{TbMn}_2$  intermetallic compound by substitutions of Fe for Mn. (Poster)

BALLOU R., BROWN P.J., DEPORTES J., MARKOSYAN A.S., OULADDIAF B. Exchange frustration and metastability of the magnetic structure of  $\text{TbMn}_2$ . (Poster)

BELLOUARD C., HENNION M., MIREBEAU I., DIANOX A.J., CAIGNAERT V. Inelastic neutron study in superconducting  $\text{YBa}_2(\text{Cu}_{1-x}\text{Co}_x)_3\text{O}_7$ . (Contributed paper)

BLANCO J.A., FERNANDEZ-BARQUIN L., GIGHOUX D., GOMEZ-SAL J.C., RODRIGUEZ-CARVAJAL J., RODRIGUEZ-FERNANDEZ J. Magnetic structures and cerium moment reduction in the  $\text{CeNi}_x\text{Pt}_{1-x}$  ferromagnetic Kondo lattices.

BOOTH J.G., COSTA M.M.R., RODRIGUEZ-CARVAJAL J., PAIXAO J.A. Magnetic phase diagram of the dilute Cr-Ge system.

BROWN P.J., DEPORTES J., NEUMANN K.-U., ZIEBECK K.R.A. High temperature magnetization distribution in Nickel.

BRÜCKEL T., PRANDL W., HAGDORN K. Neutron scattering investigation of the magnetic structure and phase transitions in  $\text{CoNiTAC}$  mixed crystals.

CHATTOPADHYAY T., BROWN P.J., STEPANOV A.A., ZVYAGIN A.I., BARILO S.N., ZHIGUNOV D.I. Antiferromagnetic ordering in  $\text{Gd}_2\text{CuO}_4$ .

CHATTOPADHYAY T., McINTYRE G.J., VETTIER C., BROWN P.J., FORSYTH J.B. Magnetic excitations and spin correlations in  $\text{CuO}$ . (Poster)

DEL MORAL A., SCHWEIZER J., ARNAUDAS J.I.,

SALAMON M.B., RITTER C., JOVEN E., GEHRING P.M., ALGARABEL P.A., CULLEN J. Ferro-, quasiferro- and antiferromagnetic spin glass orders in random anisotropy crystalline  $Dy_xY_{1-x}Al_2$  compounds. (Talk)

GARCIA-MUNOZ J.L., RODRIGUEZ-CARVAJAL J., KILCOYNE S.H., BOARDMAN C.J., CYWINSKI R. Magnetic correlations in  $YBa_2(Cu_{1-x}Fe_x)_3O_{6+y}$ .

GARCIA-MUNOZ J.L., RODRIGUEZ-CARVAJAL J., OBRADORS X. Magnetism in the rare earth cuprates  $R_2Cu_2O_5$  (R=Y, Ho, Er, Yb, Tm).

HEAP R.T., MITCHELL P.W., NEEDHAM L.M. Low energy spin wave excitations in  $Ni_{60}Fe_{40}$ .

HINRICHS K., HERZ K., KNORR K., MAY H.-J., POHL J., PRANDL W. Experimental evidence for a second transition due to Ising ions in amorphous Heisenberg spin glasses.

HOCK R., BARUCHEL J., FUESS H., ANTONINI B., PAROLI P. The spin reorientation in erbium iron garnet: a neutron and X-ray topographical study.

IBARRA M.R., MARQUINA C., PAVLOVIC A.S., RITTER C. Structural and magnetic phase diagram of the series  $(Tb_xY_{1-x})Cu$ .

JEHAN D.A., McMORROW D.F., COWLEY R.A., McINTYRE G.J. The magnetic structure of holmium in an applied magnetic field.

LOEWENHAUPT, M., HOFFMANN P., SOSNOWSKA, I., FRICK B. Temperature dependent neutron scattering experiments on  $Dy_2Fe_{14}B$ . (Poster)

MALETTA H., CHATTOPADHYAY T., BROWN P.J., POERSCHKE E. Effect of oxygen removal on the magnetic order of Er in  $ErBa_2Cu_3O_x$ . (Poster)

MARSHALL W.G., MURANI A.P., McEWEN K.A. 5f-electron spin dynamics in  $U(Sn_{3-x}In_x)$ .

MAYER H.M., STEINER M., STÜSSER N., WEINFURTER H., DORNER, B., LINDGÅRD P.A., CLAUSEN K.N., HOCK S., VERHOEF R. Inelastic neutron scattering measurements on  $Nd_2Fe_{14}B$  and  $Y_2Fe_{14}B$  single crystals. (poster)

MURPHY H.M., NEUMANN K.U., VISSER D., ZIEBECK K.R.A. Crystallographic structure and magnetic ground state of  $CeSi_x$ .

NEUMANN K.U., CAPELLMANN H., SCHÄRPF O., ZIEBECK K.R.A. Dynamic susceptibility of the heavy fermion system  $CeCu_2Si_2$ .

NUTLEY M.P., BOOTHROYD A.T., McINTYRE G.J. Magnetisation density in  $PrBa_2Cu_3O_7$  by polarized neutron diffraction.

PAYEN C., MUTKA H., SOUBEYROUX J.L., MOLINIE P., COLOMBET P. Static and dynamic properties of the quasi-1D Heisenberg antiferromagnets  $AgVP_2S_6$  (S=1) and  $AgCrP_2S_6$  (S=3/2). (Poster)

PIERRE J., AUFFRET S., LAMBERT-ANDRON B., MADAR R., MURANI A.P., SOUBEYROUX J.L. Magnetic and transport properties of rare earth silicides  $RSi_{2-x}$ .

RITTER C., MONDAL S., KILCOYNE S.H., CYWINSKI R., RAINFORD B.D. The magnetic phase diagram of  $(Dy_xY_{1-x})Mn_2$  alloys.

ROSSAT-MIGNOD J., REGNAULT L.P., VETTIER C., BOURGES P., BURLET P., BOSSY J., HENRY J.Y., LAPERTOT G. Inelastic neutron scattering study of the spin dynamics in  $YBaCu_3O_{6.92}$ .

SANDONIS J., BARUCHEL J., SCHLENKER M., PEARCE A. The shape of the interface between the heli and ferromagnetic phases. (Poster)

SANDONIS J., PEARCE A., BARUCHEL J., PARLINSKI K., PALMER S.B. Temperature variation related movement of chirality domain walls in helimagnets. (Poster)

SANDONIS J., BARUCHEL J., TANNER B.K., FILLION G., KVARDAKOV V.V., PODURETS K.M., Coupling between antiferro- and ferromagnetic domains in hematite. (Poster)

SCHMID B., DORNER B., VISSER D., STEINER M. Magnetic field and temperature dependent correlations in the singlet ground state system  $CsFeBr_3$ . (Poster)

SEVERING A. Neutron studies of heavy fermions.

TANNER B.K., BARUCHEL J., ABELL J.S. Internal magnetic domain structures changes in thick  $TbAl_2$  crystals revealed by polarized neutron topography.

TIETZE-JAENSCH H., SIEGER D., JAITNER H., GEICK R., SCHWEISS P., TREUTMANN W., REGNAULT L.P., FÅK, B. Magnetic disorder in the spin-flop phase of  $Rb_2MnCl_4$ .

#### FUKUOKA, Japan: Conference on Slow Dynamics in Condensed Matter - 1991/11

MAGERL A., LISS K.D., SCHNEIDER J.R., ZULEHENER W. An in-situ study of the dynamics of oxygen precipitation in Si.

#### GAITHERSBURG, USA: NIST Workshop on Applications of Cold Neutron Spectroscopy in Chemistry, Biology and Physics - 1991/06/4-5

MAGERL A. Update on high resolution neutron spectroscopy at the ILL.

ZACCAI G. Neutron scattering in biology 1991. (Invited talk)

#### GARCHY, France: 2nd Meeting on Disorder in Molecular Solids - 1991/06/24-2

FRICK B. Incoherent inelastic neutron scattering on highly crystalline (1,4)-trans-polybutadiene. (Extended abstract)

PETRY W. Critical slowing down of relaxations at the glass transition in a fragile and an orientational glass.

**GRENOBLE, France: HERCULES Course  
- 1991/01/28 - 03/22**

- BARUCHEL J. X-ray and neutron topography.  
LEHMANN M.S. High and low resolution in neutron crystallography.  
MARMEGGI J.C. Search in reciprocal space with both neutron and synchrotron radiation in order to study  $\alpha$ -U. (Invited talk)  
MARTINEZ J.L. Layers - multilayers - superlattices. (Invited talk)  
PANNETIER J. Powder diffraction techniques.

**GRENOBLE, France: ILL Workshop on the Analysis of Small Angle Neutron Scattering and Neutron Reflectivity - 1991/03/25-27**

- AL USTA K. Surface-Sensitive Neutron Scattering. (talk)  
AL USTA K. EVAnescent wave neutron diffraction.

**GRENOBLE, France: ILL Cluster-based Training Session on the Use of Neutron Scattering in Physics, Chemistry and Biology - 1991/07/2-10**

- BARUCHEL J. Neutron diffraction topography.  
DORNER B. Inelastic neutron scattering from spin waves. (Invited lecture)  
FARAGO B. Neutron spin-echo and applications.  
LEHMANN M.S. Biological structure as seen by neutrons.  
MAGERL A. Neutron beam conditioning.  
MAY R. Neutron small-angle scattering.  
PENDLEBURY J.M. Physics of ultra cold neutrons.  
RODRIGUEZ-CARVAJAL J. Neutron elastic scattering: structural studies on powders and single crystals.  
TASSET F. Neutron polarization and polarimetry.

**GRENOBLE, France: GAMS - réunion du groupe Sud-Est - 1991/11/28**

- ZACCAI G. Diffraction et spectroscopie neutronique de protéines. (Invited talk)

**HAMBURG/Saar, Germany: Jahrestagung der Deutschen Gesellschaft für Biophysik - 1991/10/6-9**

- LEDERER H., SCHATZ O., MAY R.P., HOWARD K.J., BAER G., CRESPI H.L., DARLIX J.-L., LE GRICE S.F.J., NEUMANN H. Structure and function of HIV - 1 reverse transcriptase.

**ISOLA D'ELBA, Italy: International school on Quantum Solids, Liquids and Gases - 1991/06**

- LAUTER H.J., GODFRIN H., LEIDERER P.  $^4\text{He}$  films on graphite studied by neutron scattering.

**JOUY-EN-JOSAS, France: French-Soviet Seminar on Strongly Correlated Electronic Systems - 1991/12/9-11**

- DIANOUX A.J., ROSSEINSKY M.J., PRASSIDES K., DAY P. Phonon density of states of (Ba,K) (Pb,Bi,Sb)O<sub>3</sub> ceramic oxides.

**JÜLICH, Germany: International Conference on Nuclear Data for Science and Technology - 1991/05/13-17**

- WAGEMANS C., DRUYTS S., WEIGMANN H., BARTHELEMY R., SCHILLEBEECKX P., GELTENBORT P. (n,p) and (n, $\alpha$ ) cross-section measurements with astrophysical applications.  
KAUFMANN J., BOUCHENE N., MEDKOUR G., ASGHAR M., GOENNENWEIN F., MOLLENKOPF W., BARREAU G., DOAN T.P., LEROUX B., SICRE A., GELTENBORT P., Fragment yields from the fission reactions  $^{232}\text{U}(n,f)$  and  $^{239}\text{Pu}(n,f)$ .

**JÜLICH, Germany: Workshop Structures and Conformation of Membranes - 1991/09/16-18**

- CHARVOLIN J. Films of amphiphiles and minimal surfaces. (Invited talk)  
MOSSERI R., SADO C.J.F., CHARVOLIN J. Toroidal vesicles. (Poster)

**KANAZAWA, Japan: HSTcM2, International Conference on Materials and Mechanisms of Superconductivity, High Temperature Superconductors - 1991/07/22-26**

- DE GROOT P., YOUNG T., RAINFORD B.D., WELLER M.T., GRASMEDER J.R., SCHÄRPF O. Return of antiferromagnetic long range order upon La doping in YBa<sub>2</sub>Cu<sub>3</sub>O<sub>7+y</sub>.  
FERNANDEZ-DIAZ T., MARTINEZ J.L., RODRIGUEZ-CARVAJAL J., ODIER P., FILLION G., BEILLE J., BARBARA B., CYROT M. Magnetic field induced transitions in Pr<sub>2</sub>NiO<sub>4</sub> single crystals.  
GARCIA-MUNOZ J.L., OBRADORS X., KILCOYNE S.H., CYWINSKI R. A  $\mu\text{SR}$  search for localised moments in YBa<sub>2</sub>(Cu<sub>1-x</sub>Zn<sub>x</sub>)<sub>3</sub>O<sub>7</sub>.  
ROSSAT-MIGNOD J., REGNAULT L.P., VETTIER C., BOURGES P., BURLET P., BOSSY J., HENRY J.Y., LAPERTOT G. Neutron scattering study of the YBa<sub>2</sub>Cu<sub>3</sub>O<sub>6+x</sub> system.

**KIRCHBERG, Austria: International Winter School on Electronic Properties of Polymers - 1991/3/9-16**

- VOIT J. Percolation in conducting polymers - Well and alive !

**KONSTANZ, Germany: Xth Sagamore Conference on Charge Spin and Momentum Densities - 1991/09/1-7**

- BROWN P.J. What can we learn from magnetisation densities ? A review of recent polarised neutron studies. (Invited paper)

**LA GRANDE MOTTE, France: Journées des Polymères Conducteurs - 1991/10/16-18**

FOXONET N., BERNIER P., VOIT J. Conductivity of n-doped polyacetylene: dependence on doping level and temperature.

SAUVAJOL J.L., DJURADO D., DIANOUX A.J., FISCHER J.E. Densités d'états des modes de réseau dans les polymères conjugués. Une étude par diffusion incohérente des neutrons.

**LEKEITIO-BILBAO, Spain: International Workshop on Methods of Structure Analysis of Modulated Structures and Quasicrystals - 1991/04/29 - 05/4**

JANOT C. The structure of quasicrystals. An introduction.

JANOT C. Contrast variation for n-dimensional crystallography.

MARMEGGI J.C. Contribution of white beam diffraction to the investigation of modulated phase transitions.

BOUDARD M., JANOT C., BOISSIEU M. DE, DUBOIS J.M., DONG C. The structure of the icosahedral AlPdMn Quasicrystal.

PAPOULAR R.J., DE BOISSIEU M., JANOT C. The maximum entropy method in quasicrystallography.

**LES ARCS, France: XIth Moriond Workshop Tests of Fundamental Laws in Physics - 1991/1/26 - 02/2**

LAST J. Angular correlations in free neutron decay.

PENDLEBURY J.M. Measuring the neutron lifetime using stored neutrons.

**LES HOUCHES, France: Workshop on Dynamical Phenomena at Interfaces, Surfaces and Membranes - 1991/2/18-28**

WORTIS M., SEIFERT U., BERNDL K., FOURCADE B., MIAO L., RAO M., ZIA R.K.P., Curvature-controlled shapes of lipid-bilayer vesicles: budding, vesiculation and other phase transitions.

UWAHA M., SAITO Y., SEKI S., Aggregation in a diffusion field - velocity selection via fractal dimension of DLA and a flow-induced first order transition.

**LEXINGTON, USA: 19th Rare Earth Conference - 1991**

SEVERING A., THOMPSON J.D., CANFIELD P.C., FISK Z. Gap in the magnetic excitation spectrum of  $Ce_3Bi_4Pt_3$ .

**MADRID, Spain: NATO ASI on Defects and Disorder in Crystalline and Amorphous Solids - 1991/9/15-28**

RODRIGUEZ-CARVAJAL J. Neutron powder diffraction for the characterization of structural defects in crystalline solids. (talk)

**MANIZALES, Colombia: Simposio sobre Magmatismo Andino y su Marco Tectónico' - 1991/07/3-5**

OLIVER R.A., VATIN-PERIGNON N., GOEMANS P. Geochemical constraints on the evolution of the Southern peruvian coastal batholith: toquepala segment. (talk)

VATIN-PERIGNON N., OLIVER R.A., GOEMANS, KELLER F., BRIQUEU L., SALAS G.A. Subduction in the Northern part of the central volcanic zone from the geochemical evolution and quantification of the crustal contamination of the Nevado Solimana volcano, Southern Peru.

VATIN-PERIGNON N., DELMAS R.J., OLIVER R.A., GOEMANS P., KELLER F., KIRCHNER S., PALAIS J., SALAS G.A. The February 18, 1600 AD plinian eruption of the Huaynaputina Volcano (Province de Moquegua, Central Andes of Southern Peru): a sulphur-acid rich eruption. (oral presentation)

**MATALASCAÑAS, Spain: 3rd International Workshop on Non-Crystalline Solids - 1991/11/5-8**

COLMENERO J., ARBE A., ALEGRIA A., FRICK B. Quasielastic neutron scattering study of the dynamics of the  $\alpha$ -relaxation in polymers.

**MOSCOW, USSR: International Conference on Diffusion and Defects in Solids - 1991/6/25 - 7/5**

PETRY W. Direct calculation of migration energies from the phonon dispersion in bcc metals.

**MÜNSTER, Germany: Frühjahrstagung der Deutschen Physikalischen Gesellschaft - 1991/04/8-12**

AL USTA K., DOSCH H., LIED A., PEISL J. Oberflächensensitive Neutronenstreuung unter Totalreflektion. (talk)

DORNER B., VISSER D., STEINER M. Magnetische Anregungen in  $CsFeBr_3$  untersucht mit polarisierten Neutronen. (Poster)

ENDERLE M., KAKURAI K., STEINER M., WEINFURTER B., DORNER B. Untersuchungen zum Haldane-Problem mittels inelastischer Neutronenstreuung. (Poster)

FRICK B., RICHTER D., ZORN R. Untersuchung des Glasübergangs in Polymeren mittels Neutronenstreuung und Test der Modenkopplungstheorie. (talk)

HAHN W., LOEWENHAUPT M., FRICK B. Kristallfeldaufspaltungen in verdünnten Seltenen-Erd-Metallegierungen. (talk)

STUHR U., WIPF H., FRICK B. Wasserstoffdiffusion in kubisch flächenzentriertem  $TiH_x$ . (talk)

VOIT J. Einfluss von Librationsfreiheitsgraden auf elektronische Eigenschaften von Polyanilin.

**MÜNSTER, Germany: 10th International Conference on Solid Compounds of Transition Elements - 1991/05/21-25**

ISNARD O., MIRAGLIA S., SOUBEYROUX J.L., FRUCHART D., DESPORTES J., GUILLOT M. Magnetic changes induced by insertion of H and N in  $R_2Fe_{17}$  compounds and neutron location of the inserted atoms. (Poster)

ISNARD O., MIRAGLIA S., FRUCHART D., L'HERITIER P. Coercivity in hydrogen decrepitated  $Sm_2Co_{17}$ -type compounds. (Poster)

**NANTES, France: Hicopol, European Symposium on Highly Conducting Polymers - 1991/09/23-24**

VOIT J. Percolation in conducting polymers - Well and alive !

**NAUROD, Germany: Photonik: Organische Festkörper und Polymere - 1991/06/20-22**

VOIT J. Percolation in conducting polymers - Well and alive !

VOIT J. Einfluss von Librationsfreiheitsgraden auf elektronische Eigenschaften von Polyanilin.

**NEW-YORK, USA: APS/AC Symposium on Thermoreversible gelation of polymers, - 1991/08/25-30**

TERECH P. (title not available).

**NIKHEF-AMSTERDAM, Holland: Preparation Meeting for the European Workshop on X-ray Detectors for Synchrotron Radiation Sources - 1991/07/2-3**

OED A. Micro strip detectors.

**NIKHEF-AMSTERDAM, Holland: EPS Conference on Hadronic Structure and Electroweak Interactions - 1991/08/6-10**

PENDLEBURY J.M. Steps to improve the measurement of the neutron electric dipole moment.

**ORLEANS, France: 6th International Symposium on Intercalation Compounds - 1991/05/27-31**

PILLIERE H., SOUBEYROUX J.L., GOLDMANN M., BEGUIN F. Physintercalation of alkanes in  $CsC_{24}$ : influence of the molecular size on the structural modifications. (talk)

**ORLEANS, France: Workshop on Lattice Dynamics of High  $T_c$  Materials - 1991/06**

MARTINEZ J.L. Neutron studies of  $La_2NiO_4$ .

**OXFORD, U.K.: Meeting on Recent Developments in the Physics of Fluids - 1991/04/3-5**

SUCK J.-S. Neutron Brillouin scattering from fluids.

**OXFORD, UK: International Conference on Neutron Scattering - 1991/08/27-30**

ALEKSEEV P.A., LAZUKOV V.N., ORLOV V.G., SADIKOV I.P., SUCK J.B. Inelastic magnetic neutron scattering study of amorphous to crystal transition for  $PrNi_{15}$ .

ALLENSPACH P., FURRER A., MESOT J., STAUB U., GUILLAUME M., FISCHER P., KRAMER M.J., SANG-IM Y., BLANK H., MUTKA H., OSBORN R., ARAI M., BOWDEN Z. Neutron spectroscopy and diffraction studies of  $Nd_{1+x}Ca_yBa_{2-x-y}Cu_3O_z$  ( $0 \leq x \leq 0.5$ ;  $y=0, 0.25; 6.09 \leq z \leq 7.04$ ). (Poster)

ALTORFER F., BUEHRER W., ANDERSON I., SCHÄRPF O., BILL H., CARRON P.L., SMITH H.G. Lithium diffusion in the superionic.

AL USTA K., DOSCH H., LIED A., PEISL J. Surface sensitive neutron scattering. (Poster and oral presentation)

ANDERSEN K.H., STIRLING W.G., SCHERM R., STUNAULT A., FÅK B., GODFRIN H., DIANOUX A.J. Precision determination of  $S(Q,\omega)$  of liquid  $^4He$  as a function of temperature.

ANDERSEN K.H., STIRLING W.G., TAYLOR A.D., BENNINGTON S.M., BOWDEN Z.A., BAILEY I., GLYDE H.R. Final state effects in  $S(Q,\omega)$  of liquid  $^4He$  at intermediate momentum transfer.

AYACHE C., CURRAT R., MOLINIE P. Study of the mode-softening in  $NbSe_{2-2H}$ .

BERMEJO F.J., MARTINEZ J.L., MARTIN-MARERO D., MOMPEAN F.J., GARCIA-HERNANDEZ M., CHAHID A. Coherent excitations in liquid deuterium.

BERMEJO F.J., MARTINEZ J.L., MOMPEAN F.J., CHAHID A., GARCIA-HERNANDEZ M. Inelastic scattering from molecular liquids and glasses.

BLANCO J.A., GIGNOUX D., GOMEZ-SAL J.C., RODRIGUEZ-CARVAJAL J., RODRIGUEZ-FERNANDEZ J., SCHMITT D. Magnetic structures of the orthorhombic  $GdNi_{1-x}Cu_x$  compounds.

BOOTHROYD A.T., STIRLING W.G., CURRAT R., BERNHOEFT, McPAUL D.K., SHIHUB S.I.K. Neutron scattering study of the electron-phonon interaction in superconducting Niobium.

BRAMWELL S.T., HUTCHINGS M.T., FÅK B. The dynamic critical scattering of a 2D-planar ferromagnet:  $Rb_2CrCl_4$ .

BROWN P.J., HAYDEN S.M., LANDER G.H., ZARESTKY J., STASSIS C., METCALF P., HONIG J.M. Observation of incommensurate two-dimensional magnetic correlations in  $La_{1.8}Sr_{0.2}NiO_4$ . (Contributed paper)

BRÜCKEL T. A thermal flat cone diffractometer for polarization analysis.

- CACIUFFO R., AMORETTI G., BLAISE A., FOURNIER J.M., HUTCHINGS M.T., LANDER G.H., OSBORN R., SEVERING A., TAYLOR A.D. Neutron inelastic experiments on actinide dioxides: search for crystal field excitations.
- CARLILE C.J., MUKHOPADHYAY R., SILVER R.N., FILLAUX F., PRAGER M., KEARLEY G.J., HEIDEMANN A., COCKCROFT J. Higher resolution and numerical deconvolution: complementary techniques for complex spectra ? (Talk)
- CHATTOPADHYAY T., BRÜCKEL T., BURLET P. Spin correlations in  $MnS_2$ .
- CHATTOPADHYAY T., FRICK B. Hydrogen motions and structural phase transitions in  $ZnTiF_6 \cdot 6H_2O$  and  $MnTiF_6 \cdot 6H_2O$ .
- DORNER B. Structural excitations and phase transformation.
- DU PLESSIS P. DE V., LANDER G.H., STRYDOM A.M., FÅK B. Phonon softening in  $UO_2$ .
- ELLERBY M., McEWEN K.A., NEEDHAM L.M. Magnetic ordering in praseodymium alloys.
- ENDERLE M., KAKURAI K., STEINER M., DORNER B. Investigation of eigenvectors in the Haldane-system  $CsNiCl_3$  by polarized inelastic neutron scattering. (Poster)
- EVEN J., CAILLEAU H., TOUDIC B., BERTAULT M., MOUSSA F., CURRAT R. Neutron study of the structural transition in a polymerizable crystal: pTS-D.
- FERNANDEZ-DIAZ M.T., RODRIGUEZ-CARVAJAL J., MARTINEZ J.L., ODIER P. Low temperature phase and magnetic ordering in  $Pr_2NiO_4$ .
- FILLAUX F., CARLILE C.J., KEARLEY G.J. Methyl tunneling and quantum sine-Gordon breather modes in partially deuterated 4-methyl-pyridine.
- FILLAUX F., FONTAINE J.P., BARON M.H., TOMKINSON J., KEARLEY G.J. Inelastic neutron scattering intensities and force field calculations: normal versus local mode picture.
- FRICK B., ZORN R., RICHTER D. Low frequency scattering near the glass transition in polymers with different microstructure.
- FULTON S., NAGLER S.E., COWLEY R.A., NEEDHAM L.M. Spin waves in the quasi two-dimensional antiferromagnet  $KFeF_4$ .
- GABRYS B., SCHÄRPF O. Scattering from polymers using polarised neutrons: a new development.
- GARCIA-MUÑOZ J.L., RODRIGUEZ-CARVAJAL, LACORRE P. Electronically induced structural distortion across the metal-insulator transition in  $RNiO_3$  ( $R=Pr, Nd, Sm$ ).
- GOFF J.P., CLAUSEN K., FÅK B., HADFIELD R., HAYES W., HULL S., HUTCHINGS M.T. Diffuse neutron scattering from anion-excess strontium chloride.
- GOMEZ-GARCIA C.J., CORONADO E., BORRAS-ALMENAR J.J., AEBERSOLD M., GÜDEL H.U., MUTKA H. Magnetic excitations in an exchange-coupled tetramer cluster of cobalt(II). A study by inelastic neutron scattering. (Poster)
- GOMPF F., RENKER B., MUTKA H. Strong changes in the phonon density of states for  $Li_{1+x}Ti_{2-x}O_4$  when going from  $x=0$  (superconductor) to  $x=1/3$  (insulator). (Poster)
- HAHN W., LOEWENHAUPT M., FRICK B. Crystal field excitations in dilute rare earth noble metal alloys.
- HENNION M., MIREBEAU I., BOUDARENE L., BELLOUARD C., JEHANNO G., DIANOUX A.J., CAIGNAERT V. Iron spin fluctuations in the orthorhombic phase of  $YBa_2(Cu_{1-x}Fe_x)_2O_7$ : an inelastic neutron scattering study.
- HEWAT A.W. Limit to  $T_c$  in oxide superconductors studied by neutron powder diffraction
- HILFRICH K., NEMBACH K., PETRY W., SCHÄRPF O., NEMBACH E. Superlattices in iron-rich iron-aluminium alloys.
- HINRICHS K., BRÜCKEL T., KNORR K., PRANDL W. Percolation like behaviour in amorphous spin glasses  $Mn_xLa_{3-x}Al_2(SiO_4)_3$ .
- IBARRA M.R., MARQUINA C., MOZE O., IBBERSON R.M., PAVLOVIC A.S., RITTER C. Structural transformation in  $Tb_{0.1}Y_{0.9}Cu$ .
- ISNARD O., SOUBEYROUX J.L., MIRAGLIA S., FRUCHART D., GARCIA L.M., BARTOLOME J. Neutron powder diffraction study of the desorption of deuterium in  $Nd_2Fe_{17}D_{x=5}$ .
- ISNARD O., SOUBEYROUX J.L., MIRAGLIA S., FRUCHART D., GARCIA L.M., BARTOLOME J. Neutron powder diffraction study of the reaction of  $Nd_2Fe_{17}$  compound with nitrogen gas.
- JONES D.L., LANGRIDGE S., STIRLING W.G., LANDER G.H., REBIZANT J., SPIRLET J.C., ALBA M., VOGT O. Critical scattering measurements on neptunium arsenide.
- KEARLEY G.J. Time-focussing with multi-slit disk-choppers, a future spectrometer.
- KEARLEY G.J., TOMKINSON J. The inelastic neutron scattering spectrum of  $Sn(CH_3)_4$ .
- KIRSTE R.G., SALIE H., LINDNER P. Structure of polyetherketones.
- KULDA J., MIKULA P., LUKAS P., KOCSIS M. Utilisation of bent Si crystals for elastic strain measurements.
- LAMERS C., SCHÄRPF O., SCHWEIKA W., BATOULIS J., SOMMER K., RICHTER D. Short range order in amorphous polycarbonates.
- LESIEUR P., LINDNER P., DESFORGE C., LAMBARD J., ZEMB T. Comparison of pinhole and linearly collimated SAXS and SANS studies of emulsified oil droplets.

- LINDNER P. Large scale structures under shear. (talk)
- LINDNER P., MAY R.P., TIMMINS P.A. Upgrading of the SANS instrument D11 at ILL.
- MARMEGGI J.C., CHENEVIER B. Magnetic neutron white beam diffraction through phase transitions in MnRhAs. (Poster)
- MARSHALL W.G., McEWEN K.A., FORT D. Neutron magnetic scattering from UPb<sub>3</sub>.
- MARTINEZ J.L. Magnetic study of 3d-metal superlattices: a neutron and magnetization study. (Invited talk)
- MEDARDE M., RODRIGUEZ-CARVAJAL J., OBRADORS X., VALLET-REGI M., GONZALEX-CALBET J.M., ALONSO J. Spin reorientations in Nd<sub>1.8</sub>Sr<sub>0.2</sub>NiO<sub>3.8</sub>.
- MEDARDE M., RODRIGUEZ-CARVAJAL J., OBRADORS X., VALLET-REGI M., GONZALEX-CALBET J.M., SAYAGUES M.J. Oxygen vacancy ordering in La<sub>2-x</sub>Sr<sub>x</sub>NiO<sub>4-δ</sub>.
- MEINNEL J., TAZI M., SANQUER M., MANI M., NUSIMOVICI M., WYNCKE B., HEIDEMANN A., HENNION B., TOMKINSON J. Comparative study of methyl rotor's levels in 1 3 5 trihalogeno 2 4 6 trimethylbenzenes. (Poster)
- MESOT J., STAUB U., ALLENSPACH P., FURRER A., MUTKA H., HEWAT A. Pressure-induced charge redistribution in ErBa<sub>2</sub>Cu<sub>3</sub>O<sub>x</sub> determined by neutron crystal-field spectroscopy. (Poster)
- MONDAL S., CYWINSKI R., KILCOYNE S.H., RAINFORD B.D., RITTER C. Pressure dependence of the magnetic order in YMn<sub>2</sub> and TbMn<sub>2</sub>.
- MONDAL S., CYWINSKI R., KILCOYNE S.H., RAINFORD B.D., RITTER C. Low temperature structural distortions in RMn<sub>2</sub>.
- MORON M.C., PALACIO F., RODRIGUEZ-CARVAJAL J. Neutron powder diffraction experiments on AMnF<sub>4</sub> (A=K,Rb): nuclear and magnetic structures.
- MURPHY H.M., NEUMANN K.U., VISSER D., ZIEBECK K.R.A. Investigation of the crystallographic properties of CeSi<sub>x</sub> and their relation to a magnetically ordered ground state.
- MUTKA H. Focussing monochromator - Fermi-chopper time-of-flight spectrometer.
- MUTKA H., PAYEN C., MOLINIE P., SOUBEYROUX J.L., COLOMBET P., TAYLOR A.D. Magnetic correlations in the S=1 quasi-one-dimensional Heisenberg antiferromagnet AgVP<sub>2</sub>S<sub>6</sub>. (Poster)
- NEMBACH E., HILFRICH K., EBEL T., SCHÄRPF O. Order in commercial grain-oriented iron-silicon sheets.
- NEUMANN K.U., SCHÄRPF O., ZIEBECK K.R.A. On the question of the origin for a spherical average in scattering experiments.
- OULADIAFF B., DEPORTES J., GALERA R.M., MARKOSYAN A.S., SOUBEYROUX J.L. The 3d Mn magnetism instability in TbMn<sub>2</sub>.
- POUGET S., ALBA M., FANJAT N., NOGUES M. Crystal structure and magnetic interactions in CdCr<sub>2</sub>S<sub>4</sub>: a simple insulating ferromagnet.
- PRASSIDES K., BELL C.J., DIANOUX A.J., CHUNGUEY WU., KANATZIDIS M.G. Phonon studies of intercalated conductive polymers.
- PRASSIDES K., ROSSEINSKY M.J., DIANOUX A.J., DAY P. Phonon softening in ceramic superconductors.
- RAISON P., DELAPALME A., LANDER G.H., CARLILE C., WILLIAMS J., KANELAKOPOULOS B., APOSTOLIDIS C., REBIZANT J. Study of motion of cyclopentadienyl rings in UCp<sub>3</sub>Cl by quasielastic neutron scattering.
- RENKER B., GOMPF F., EWERT D., MUTKA H., Electron-phonon coupling in HT<sub>c</sub>-superconductors evidenced by inelastic neutron scattering. (Poster)
- ROESSLI B., ALLENSPACH P., FISCHER P., FURRER A., MESOT J., STAUB U., MALETTA H., BRÜESCH P., RITTER C., HEWAT A.W. Crystal structures and long-range antiferromagnetic ordering due to rare earth ions (R<sup>3+</sup>) in superconductors RBa<sub>2</sub>Cu<sub>3</sub>O<sub>7-δ</sub> (R=Nd,Yb).
- ROSSAT-MIGNOD J., REGNAULT L.P., VETTIER C., BOURGES P., BURLET P., BOSSY J., HENRY J.Y., LAPERTOT G. Spin dynamics in the high T<sub>c</sub> system YBa<sub>2</sub>Cu<sub>3</sub>O<sub>6+x</sub>.
- STAUB U., ALLENSPACH P., FURRER A., MESOT J., FISCHER P., KALDIS E., KARPINSKI J., RUSIECKI S., MÜLLER R., SCHWEIZER T., GAUCKLER L.J., BLANK H., MUTKA H. Neutron spectroscopy and diffraction studies of the high-T<sub>c</sub> superconductor HoBa<sub>2</sub>Cu<sub>3</sub>O<sub>x</sub>, HoBa<sub>2</sub>Cu<sub>4</sub>O<sub>8</sub> and Bi<sub>2</sub>Zr<sub>x</sub>Ca<sub>y</sub>Ho<sub>z</sub>Cu<sub>2</sub>O<sub>8+δ</sub>. (Poster)
- STUNAU A., ANDERSEN L.K.H., BLANC Y., FÅK B., GODFRIN H., GUCKELBERGER K., SCHERM R. TOF spectroscopy: energy calibration and consistency check.
- TASSET F., CHUPP T.E., PIQUE J.P., STEINHOF A., THOMPSON A., WASSERMAN E., ZIADE M. First test at ILL of a gaseous <sup>3</sup>He neutron polarization filter.
- TENNANT D.A., McMORROW D.F., NAGLER S.E., FÅK B. Spin waves in the spin-flop phase of RbMnF<sub>3</sub>.
- TERECH P. Small angle neutron scattering from DNA molecules during gel electrophoresis. (Invited talk)
- TOMKINSON J., KEARLEY G.J. The effect of recoil of chemically-distinct molecular ions on INS spectra of molecular vibrations.
- TRAMPENAU J., PETRY W., HEIMING A. Phonons in the bcc phase of Sc.
- VERKERK P., BAFILE U., BAROCCHI F., DE GRAAF L.A., SUCK J.-B., MUTKA H. Experimental

determination of the linear term in the density expansion of the dynamic structure factor by means of neutron scattering.

ZACCAI G. Impact of neutron scattering on biology. (Invited talk)

ZORN R., RICHTER D., FARAGO B., FRICK B., KREMER F., KIRST U., FETTERS L.J. Comparative study of the segmental relaxation in polyisoprene by quasielastic neutron scattering and dielectric spectroscopy.

**PARIS, France: Séance spécialisée de la Société Géologique de France sur les granites océaniques et continentaux - 1991/03/11-13**

OLIVER R.A. Geochemistry of the Southern Peruvian coastal batholith.

VITTOZ P., VIVIER G., OLIVER R.A. Le bimagmatisme acide-basique dans les granitoïdes du Nord-Ouest du massif des Ecrins-Pelvoux: interactions et origines des magmas.

**PITTSBURGH, USA: MMM-Intermag Conference - 1991/6/18-21**

OBRADORS X., MARTINEZ B., BATLLE X., RODRIGUEZ-CARVAJAL J., FERNANDEZ-DIAZ M.T., MARTINEZ J.L., ODIER P. Magnetic transitions in  $\text{Pr}_2\text{NiO}_4$  single crystal.

**PONT D'HOYE, Belgium: Seminar on Fission - 1991/10/23-25**

FIONI G., FAUST H.R., GROSS M. Improvement of the Lohengrin spectrometer by using a focusing magnet.

**PORTO CARRAS, Halkidiki, Greece: NATO-ASI on High Temperature Superconductors II - 1991/8/18-31**

DIANOUX A.J., ROSSEINSKY M.J., PRASSIDES K., DAY P. Phonon density of states of  $(\text{Ba,K})(\text{Pb,Bi,Sb})\text{O}_3$  ceramic oxides.

**REGENSBURG, Germany: March Meeting of the German Physical Society - 1991/03/**

TRUMP R., LOEWENHAUPT M., CHATTOPADHYAY T., SEVERING A. Spinwellen im Kondo-Gitter  $\text{CeCu}_2$ .

**ROMA, Italy: International Workshop on Studies of Magnetic Properties of Fine Particles and their Relevance to Materials Science - 1991/11/4-8**

HENNION M., BELLOUARD C., MIREBEAU I., BLANK H., DORMANN J.L. Dynamics of fine particles coupled by dipolar field studied by inelastic neutron scattering.

**ROTTACH-EGERN, Germany: Symposium on Quantum Aspects of Molecular Motions in Solids - 1991/04/3-6**

ANDERSON I.S., BERK N.F., RUSCH J.J., UDOVIC T.J., CODDENS G., MAGERL A. Low temperature dynamics of hydrogen in rare earth metals.

BLANK H., KEARLEY G.J. Tunnelling behaviour in anionic mixtures of nickel hexamine salts. (Poster)

HEIDEMANN A., PETRY W., COOK J. Backscattering spectroscopy with  $1 \mu\text{eV}$  resolution at energy transfers up to  $1 \text{ meV}$  applied to study weakly hindered quantum rotors. (poster)

KEARLEY G.J. Coupling of near free rotors. (Invited talk)

**SAN DIEGO, USA: SPIE'S 1991 International Symposium on Optical Applied Science and Engineering - 1991/07/21-26**

IBEL K., MATULL R., RUPP R.A., ESCHKOETTER P., HEHMANN J. Light-induced volume phase holograms for cold neutrons.

**SENDAI, Japan: The 5th International Conference on the Structure of Non-Crystalline Materials - 1991/09/2-6**

JANOT C., BOISSIEU M. DE, BOUDARD M., VINCENT H., DURAND M., DUBOIS J.M., DONG C. Single crystal X-ray diffraction study of  $\text{AlPdMn}$  icosahedral quasicrystal. (Invited talk).

SUCK J.-B. Experimental investigation of the dynamics of amorphous and quasicrystalline alloys. (Invited talk)

SUCK J.-B., EGELSTAFF P.A., ROBINSON R.A., SIVIA D.S., TAYLOR A.D. Neutron Brillouin scattering in a metallic glass. (Contributed talk)

**ST ETIENNE, France: 8ème Colloque international Progrès dans les méthodes d'investigation des métaux et nouveaux matériaux - 1991/11/20-21**

BASTIE P., BELLET D., ROYER A., BARUCHEL J. Two non destructive techniques for the investigation of single grain turbine blades:  $\gamma$ -ray diffractometry and neutron topography.

**ST HUGUES DE BIVIERS, France: 4th French-Danish Symposium Gene Expression and Regulation' - 1991/06/14-15**

EBEL C., ZACCAI G. Elongation factor Tu from a halophilic bacterium: solution structure and stabilisation. (Invited talk)

**ST HUGUES DE BIVIERS, France: Séminaires Daniel Dautreppe 'L'Architecture Bio Moléculaire' - 1991/09/9-13**

LEHMANN M.S. Les objets biologiques cristallisés vus par les neutrons. (Lecture and Notes)

ZACCAI G. Le repliement d'une protéine: l'ordre naît du désordre. (Invited talk)

**STANMORE, UK: Congress on Biomedical Applications of Fibronectin - 1991/05/17**

VUILLARD L., ROUX B., MILLER A. A model of fibronectin conformation in solution derived from physicochemical measurements in solution.

**STRASBOURG, France: 1991-ICAM'91**

ALTORFER F., BÜHRER W., ANDERSON I., SCHÄRPF O., BILL H., CARRON P.L., SMITH H.G. Structural and dynamical properties of  $\text{Li}_2\text{S}$ .

**STRASBOURG, France: 5ème Colloque d'Expression Française sur les Cristaux Liquides - 1991/09/24-27**

TERECH P. Etude rhéologique et par diffusion de neutrons aux petits angles d'agrégats de complexes binucléaires de cuivre dans le cyclohexane.

**TAORMINA, Italy: International Workshop on Phase Separation in Multicomponent Fluids - 1991/02/25-28**

CHIEUX P. Mesoscopic and microscopic determination of liquid mixtures by neutron scattering. (Invited talk)

**TOLEDO, Ohio, USA: Annual Meeting of the American Crystallographic Association - 1991/07/**

MARTINEZ J.L. Collective excitations in molecular liquids and glasses. (Invited talk)

**TOWA, Japan: 1st Towa University International Symposium on Slow Dynamics in Condensed Matter - 1991/11/4-8**

SAITO Y., UWABA M., SEKI S. Flow-induced first order transition of the aggregation in a diffusion field. (Extended abstract)

ZORN, R., RICHTER D., FRICK B., FARAGO B. Neutron scattering experiments near the glass-transition of polybutadiene.

**TSUKUBA, Japan: Workshop on Neutron Scattering - 1991/11/11**

MAGERL A. Hydrogen tunneling in metals.

ZACCAI G. Neutrons in biology (Invited talk).

**VALENCIA, Spain: Workshop Beyond the Standard Model of Electroweak Interaction - 1991**

SCHOENERT S., SCHRECKENBACH K., NEUMAIER S., VON FEILITZSCH I. Experimental limit on a 17 keV neutrino branch in the beta decay of  $^{177}\text{Lu}$ .

**VENICE, Italy: 2nd Workshop on Basic and Applied Aspects of Rare Earths - 1991/05/**

SALINAS-SANCHEZ A., SAEZ-PUCHE R., RODRIGUEZ-CARVAJAL J., MARTINEZ J.L. Polymorphism and magnetic properties of  $\text{Tm}_2\text{BaNiO}_5$ .

**WIESBADEN, Germany: XVth General Assembly of the European Geophysical Society - 1991/04/22-26**

DRUYTS S., WAGEMANS C., GELTENBORT P., SCHILLEBEECKX P. Investigation of the  $^{35}\text{Cl}(n,p)^{35}\text{S}$  and  $^{36}\text{Cl}(n,p)^{36}\text{S}$  reactions as a function of the neutron energy. (Abstract)

**WÜRZBURG, Germany: International Conference ISA-3 - 1991/09/30 - 10/2**

BUCHENAU U., MONKENBUSCH M., REICHENAUER G., FRICK B. Inelastic neutron scattering from virgin and densified aerogels.

**ZAKOPANE : XXVI School on Physics: Condensed Matter Studies by Nuclear Methods - 1991/04/13-21**

LAUTER H.J., GODFRIN H., FRANK V.L.P., LEIDERER P.  $^4\text{He}$  films on graphite studied by neutron scattering.

## Workshops organized or sponsored by the ILL in 1991

### Aussois, France, June 23-28, 1991.

Colloque WEYL VII. International Conference on "Metals in Solution" dedicated to Prof. G. Lepoutre.

Organizers: F. LECLERCQ-HUGEUX, P. DAMAY, J. DUPUY, P. CHIEUX, J.C. THOMPSON.

### Autrans, France, September 29-October 3, 1991

XXIst European Symposium on the Dynamical Properties of Solids. (Programme and Extended Abstracts : ILL Report 91DO16G).

Organizers : R. CURRAT, B. DORNER, H. ESCHRIG.

### Buoux, France, November 4-8, 1991.

"Three-axis Group Seminar on "Fundamental Issues in Neutron Scattering".

Organizer : B. DORNER.

### Grenoble (ILL), France, March 25-27, 1991.

SANS-NR- Workshop on the "Analysis of Small Angle Neutron Scattering and Neutron Reflectivity Data".

Organizers : R.E. GHOSH, A.R. RENNIE, P. LINDNER, R.P. MAY, P.A. TIMMINS, F. RIEUTORD.

### Grenoble (ILL) , France, July 2-10, 1991.

"Cluster. Training session on the Use of Neutron Scattering in Physics, Chemistry and Biology".

Organizers : M. BEE, M. SCHLENKER.

### Rottar-Egern, Germany, April 2-6, 1991.

Symposium on "Quantum aspects of molecular motions in solids".

Organizers: A. HUELLER, W. PRESS, A. SEEGER.

## Books, conference proceedings published

### GOLUB R., RICHARDSON D., LAMOUREAUX S.K.

(Long-term visiting scientists, ILL, Grenoble).

Ultra-cold neutrons.

(Adam Hilger, 1991).

ISBN : 0-7503-0115-5 (304 pp).

### LINDNER P., ZEMB T. [Editors].

Neutron, x-ray and light scattering: Introduction to an investigative tool for colloidal and polymeric systems.

(North-Holland, 1991).

ISBN: 0-444-88946-9 (375 pp).

### METZGER R., DAY P., PAPAVALASSIOU G.C [Editors].

Lower-dimensional systems and molecular electronics.

NATO Advanced Study Institute, Series B : Physics, Vol. 248 (Plenum Press, 1990).

ISBN 0-306-43826-7 (742 pp).

### TAUB H., TORZO G., LAUTER H.J., FAIN S.C. JR [Editors].

Phase Transitions in Surface Films 2.

NATO Advanced Study Institute, Series B : Physics, Vol. 267 (Plenum Press, 1991).

ISBN: 0-306-44005-9 (498 pp).

### WYATT A. F. G., LAUTER H. J. [Editors]

Excitations in two dimensional and three-dimensional quantum fluids.

NATO Advanced Study Institute, Series B : Physics, Vol. 257

(Plenum Press, 1991).

ISBN : 0-306-43913-1 (593 pp).

## Translation

Translation from Russian to English by D. GRAY :

Papchenko A.A., Sobel'man I.I., Yukov E.A. : Optical polarisation of  $^3\text{He}$  nuclei.

## Theses

ANDERSEN K.H.

A neutron scattering study of liquid Helium-4.  
Ph. D. Thesis, University of Keele, U.K., November 1991.

BOIREAU A.

Détermination de structures cristallines et magnétiques par diffraction neutronique : Application aux phosphates de type  $A_xM_2(PO_4)_3$  et à des fluorures magnétiques.

Thèse de Doctorat, Université de Bordeaux,  
December 4, 1991.

DUITS M.H.G.

Small-angle scattering from colloidal dispersions of adhesive particles.

Proefschrift de graad van doctor, Rijksuniversiteit te Utrecht, The Netherlands, March 18, 1991.

FERRAND M.

Etude des mouvements internes de la bactériorhodopsine par diffusion inélastique de neutrons et simulation de dynamique moléculaire.

Thèse de Doctorat, Université Joseph Fourier, Grenoble,  
December 18, 1991.

GRANDATI Y.

Approches non-perturbatives en quantification stochastique.

Thèse de Doctorat, Université Joseph Fourier, Grenoble,  
October 8, 1991.

HOCK R.

Bestimmung der magnetischen Strukturen der Seltenen Erd-Eisen Granate des Erbiums und Terbioms durch elastische Neutronenstreuung.

Inaugural Dissertation zur Erlangung des Doktorgrades der Naturwissenschaften, Johan-Wolfgang Goethe-Universität, Frankfurt am Main, Germany,  
December 7, 1990.

PEARCE A.S.

Domains, phase coexistence and extinction phenomena in helical and modulated antiferromagnets.

PhD. Thesis, University of Warwick, U.K.,  
October 1991.

PFEIFFER W.

Inkohärente und kohärente quasielastische Neutronenstreuung zur Untersuchung der lokalen und kollektiven Dynamik von Lipidmodellmembranen.

Dissertation, Technische Universität München, Germany, June 27, 1990.

PILLIERE H.

Modifications structurales provoquées par la physintercalation d'alcanes dans les graphitures de césium.

Thèse de Doctorat, Université d'Orléans,  
December 18, 1991.

RASEL E.M.

Interferometrie mit sehr kalten Neutronen.

Diplomarbeit, Technische Universität München, Germany, May 1991.

RIPERT M.

Les dioxydes de manganèse électrochimiquement actifs. Modélisation structurale: modifications induites par traitement thermique et insertion protonique.

Thèse de Doctorat, Institut National Polytechnique de Grenoble, December 18, 1991.

RODRIGUEZ J.M.

Das schiefsymmetrische LLL-Zweikristallinterferometer für thermische Neutronen und Röntgenstrahlung.

Dissertation, Universität Dortmund, Germany,  
May 1991.

STEMMANN G.

Applicability of the Fermi liquid theory in strongly correlated electron systems.

Diplomarbeit, Universität Fridericiana zu Karlsruhe, Université Joseph Fourier de Grenoble, September 1991.

TRAMPENAU J.

Neutronenstreuexperimente zur Messung der Phononendispersion und ihr Zusammenhang mit der Selbstdiffusion in krz Metallen und Legierungen.

Inaugural-Dissertation, Wästfälischen Wilhelms-Universität, Münster, Germany, 1991.

UEBBING H.

Aufbau und Messungen mit dem Zweikristall-Röntgen-Neutronen-Interferometer.

Dissertation, Universität Dortmund, Germany, July 1991.

## Publications - Internal reports 1991

This list groups publications received during 1991 resulting from the research at the ILL.

ILL Reports are listed first. They are followed by the list of publications in journals, conference proceedings, books with ILL authors and co-authors and by publications related to experimental work performed by visiting scientists at the ILL but without ILL co-author.

### Internal Reports

(Code number I to 99)

(G=General Reports, T=Technical Reports).

#### 91AL01T

ALONSO J., GARCIA-HERNANDEZ M., BERMEJO F.M., MARTINEZ J.L.

SLABS: A program for absorption and shelf-shielding corrections.

Technical Report.

#### 91JU02T

JUDGE S.M.

A proposal for a measurement of positron annihilation in flight.

Technical Report.

#### 91IL03T

ILL-INSTITUT LAUE LANGEVIN

ILL Five-year development programme (1992-1996)

3ème souffle - Technical appendices November 1990

Technical Report.

#### 91CA04G

CASTETS C., SUORTTI I.

1990 ILL Experimental Reports and Theory College Activities.

General Report.

#### 91JU05T

JUDGE S.M., JONES K.

NEWFIT : Software for fitting peaks in electron spectra PN2 (BILL).

Technical Report.

#### 91CO06T

COOK J.C., PETRY W., HEIDEMANN A., FRICK B.

IN10B : High energy resolution measurements over extended energy transfer ranges on IN10.

Technical Report.

#### 91GH07T

GHOSH R.E.

SANS-NR Workshop on the Analysis of Small Angle Neutron Scattering and Neutron Reflectivity Data, 25-27 March 1991. Workshop Handbook.

Technical Report.

#### 91WU08T

WUTTKE J.

Data reduction for quasielastic neutron scattering.

Technical Report.

#### 91FA09T

FAK B., ALBA M., CURRAT R., BROCHIER A.

Flux and calibration measurements on IN14.

Technical Report.

#### 91FO10T

FOSTER N.D.

Practical implementation of a scalable transputer-based real-time data acquisition system.

Technical Report.

#### 91TS11T

TSCHERNITZ M.

Das Neutronenschwerkraftspektrometer NESSIE am ILL, Grenoble.

Technical Report.

#### 91BE12T

BECVAR F., ULBIG S.

DICEBOX : A Monte Carlo program for simulation of  $\gamma$ -cascade process in neutron capture and its application to GRID studies.

Technical Report.

#### 91ST13T

STRIDE J.A.

- C<sub>60</sub> ; The molecular sootball.

- In search of the magnetic Jahn-Teller effect.

Technical Report. (Stagiaire Report July/August 1991).

#### 91TA14G

TASSET F.

Neutron polarisation and polarimetry.

General Report.

#### 91BR15T

BRUECKEL T., VRTIS M.L.

DIFFIT-Manual including the descriptions of the AUTO-FIT, FITRES and UBM programs.

Technical Report.

#### 91DO16G

DORNER B., ESCHRIG H.

XXIst European Symposium on the Dynamical Properties of Solids, Autrans, France, September 29-October 3, 1991.

(Programme and extended abstracts).

General Report.

#### 91DO17G

DOBSON M.

Multiphonon corrections for down scattering experiments.

(Stage report July -August 1991).

General Report.

**91MA18T**

MAYERHOFER U., BOERNER H.G., JOLIE J., SCHRECKENBACH K., ULBIG S., WHITE D., WILLIAMS A.  
Discussion of an alternative installation of the PN2 (BILL) spectrometer at an external beam.  
Technical Report.

**91IL19T**

ILL- INSTITUT LAUE LANGEVIN  
Five-year development plan (1993-1997). Technical appendices. Proposal document submitted to the Steering Committee on 29 May 1991.  
Technical Report.

**91MA20T**

MAYERHOFER U.  
User's manual : programs for the evaluation of GAMS1/2/3 raw data.  
Technical Report.

**91PA21T**

PANNETIER J.  
Interaction of radiation with matter, x-rays and neutrons, elastic case: powder diffraction techniques.  
Technical Report. HERCULES-1991. Lecture Notes on Common Part 3.2 - Powder Diffraction Techniques, Grenoble, France, January 28-March 22, 1991.

**91HE22G**

HEIDEMANN A., ALEFELD B.  
Review of the applications of backscattering techniques in neutron and x-ray scattering.  
General Report.

**91IL23G**

SCAPRO  
Report on ILL Users' Meeting in Uriage on 17 October 1991.  
General Report.

**91FA24T**

FAUST H.R.  
The Lohengrin spectrometer and where it can contribute best to fission research.  
Technical Report.

**91FI25T**

FIONI G., FAUST H.R., GROSS M.  
A focusing magnet for the Lohengrin spectrometer.  
Technical Report.

**91AX26T**

AXE J.D., HEWAT A.W., MAIER J., MARGACA F.M.A., RAUCH H.  
International atomic energy agency report of consultants' meeting on Nuclear techniques in development of advanced ceramic technologies.  
Technical Report.

**91PA27T**

PANNETIER J.  
Techniques of analysis of powder diffraction patterns (X-ray and neutron). Formation Permanente du CNRS, Nantes - Septembre 16-19, 1991.  
Technical Report.

**91GO28T**

GOBERT G.  
Système de transport sur coussins d'air. Recueil de notes techniques françaises et étrangères  
Technical Report.

**91GO29T**

GOBERT G.  
Evolutions techniques choppers et sélecteurs Tome 1. Recueil de notes techniques françaises et étrangères  
Technical Report.

**91GO30T**

GOBERT G.  
Système de support sur paliers à air sur paliers magnétiques. Tome 2. Recueil de notes techniques françaises et étrangères  
Technical Report.

**91JA31T**

JAEGER R.  
A manual for the data fitting program WLL.  
Technical Report.

**Papers published in scientific Periodicals, Books and Conference Proceedings**

**1-with ILL authors and co-authors (From code number 101).**

**91BO101**

BOENI P., MARTINEZ J.L., TRANQUADA J.M.  
Longitudinal spin fluctuations in nickel.  
Physical Review **B 43**, 575-584 (1991).

**91BO102**

BOISSIEU M. DE, JANOT C., DUBOIS J.M., AUDIER M., DUBOST B.  
Atomic structure of the icosahedral Al-Li-Cu quasicrystal.  
Journal of Physics : Condensed Matter **3**, 1-25 (1991).

**91JO103**

JOLIE J., MAYERHOFER U., EGIDY T.VON, HILLER H., KLORA J., LINDNER H., TRIEB H.  
Predictive power of supersymmetry in nuclear structure tested by pickup transfer reactions to <sup>196</sup>Au.  
Physical Review **C 43**, R16-R20 (1991).

- 91FI104**  
 FISCHER J.E., MILLIKEN J.W., MAGERL A., KIM H.J., MOORE A.W.  
 Intercalated graphite neutron optical components: low-mosaic acceptor compounds with large *d*-spacings. Nuclear Instruments and Methods in Physics Research **A 300**, 207-209 (1991).
- 91EC105**  
 ECKERT J., KUBAS G.J., HALL J.H., HAY P.J., BOYLE C.M.  
 Molecular hydrogen complexes. 6. The barrier to rotation of  $\eta^2$ -H<sub>2</sub> in M(CO)<sub>3</sub>(PR<sub>3</sub>)<sub>2</sub>( $\eta^2$ -H<sub>2</sub>) (M = W, Mo; R = Cy, *i*-Pr): Inelastic neutron scattering, theoretical, and molecular mechanics studies. Journal of the American Chemical Society **112**, 2324-2332 (1990).
- 91VA106**  
 VAN DER SLUYS L.S., ECKERT J., EISENSTEIN O., HALL J.H., HUFFMAN J.C., JACKSON S.A., KOETZLE T.F., KUBAS G.J., VERGAMINI P.J., CAULTON K.G.  
 An attractive "cis-effect" of hydride on neighbor ligands: Experimental and theoretical studies on the structure and intramolecular rearrangements of Fe(H)<sub>2</sub>( $\eta^2$ -H<sub>2</sub>)(PEtPh<sub>2</sub>)<sub>3</sub>. Journal of the American Chemical Society **112**, 4831-4841 (1990).
- 91PE107**  
 PETRY W., HEIMING A., HERZIG C., TRAMPENAU J.  
 On the diffusion mechanism in bcc metals, a neutron scattering approach. Defect and Diffusion Forum **75**, 211-228 (1991).
- 91RO108**  
 ROBERTS M.P., LUCAZEAU G., KEARLEY G.J., DIANOUX A.J.  
 Quantum rotations of the ammonium ions in ammonium tetraphenyl-borate. III. Inelastic neutron scattering results. Journal of Chemical Physics **93**, 8963-8967 (1990).
- 91IH109**  
 IHRINGER J., MAICHLE J.K., PRANDL W., HEWAT A.W., WROBLEWSKI T.  
 Crystal structure of the ceramic superconductor BaPb<sub>0.75</sub>Bi<sub>0.25</sub>O<sub>3</sub>. Zeitschrift für Physik **B 82**, 171-176 (1991).
- 91FE110**  
 FERNANDEZ-DIAZ M.T., RODRIGUEZ-CARVAJAL J., MARTINEZ J.L., FILLION G., FERNANDEZ F., SAEZ-PUCHE R.  
 Structural and magnetic phase transitions in Pr<sub>2</sub>NiO<sub>4</sub>. Zeitschrift für Physik **B 82**, 275-282 (1991).
- 91HO111**  
 HOCK R., FUESS H., VOGT T., BONNET M.  
 Low temperature magnetic structure of erbium iron garnet. Zeitschrift für Physik **B 82**, 283-294 (1991).
- 91DU112**  
 DUTS M.H.G., MAY R.P., VRIJ A., DE KRUIF C.G.  
 Small-angle neutron scattering of concentrated adhesive-hard-sphere dispersions. Langmuir **7**, 62-68 (1991).
- 91AD113**  
 ADYA A.K., NEILSON G.W.  
 Structure of a 50 mol kg<sup>-1</sup> aqueous solution of ammonium nitrate at 373 K by the isotopic difference method of neutron diffraction. Journal of the Chemical Society Faraday Transactions **87**, 279-286 (1991).
- 91AL114**  
 ALAMI M., BROCHU R., SOUBEYROUX J.L., GRAVEREAU P., LE FLEM G., HAGENMULLER P.  
 Structure and thermal expansion of LiGe<sub>2</sub>(PO<sub>4</sub>)<sub>3</sub>. Journal of Solid State Chemistry **90**, 185-193 (1991).
- 91VE115**  
 VERKERK P., BAFILE U., FARAGO B., MEZEI F.  
 Neutron spin echo measurements on dense hydrogen gas. Physica **B 168**, 1-8 (1991).
- 91BO116**  
 BOERNER H.G., JOLIE J., ROBINSON S.J., KRUSCHE B., PIEPENBRING R., CASTEN R.F., APRAHAMIAN A., DRAAYER J.P.  
 Evidence for the existence of two-phonon collective excitations in deformed nuclei. Physical Review Letters **66**, 691-694 (1991).  
 Erratum : Physical Review Letters **66**, 2837 (1991).
- 91HA117**  
 HAYDEN S.M., AEPPLI G., MOOK H., RYTZ D., HUNDLEY M.F., FISK Z.  
 Magnetic fluctuations in La<sub>1.95</sub>Ba<sub>0.05</sub>CuO<sub>4</sub>. Physical Review Letters **66**, 821-824 (1991).
- 91SI118**  
 SIMON A., BOETTCHER F., COCKCROFT J.K.  
 Th<sub>6</sub>Br<sub>15</sub>H<sub>7</sub> - Stabilization of a Th<sub>6</sub>Br<sub>12</sub> cluster by seven hydrogen atoms. Angewandte Chemie. Int. Ed. Engl. **30**, 101-102 (1991).
- 91GU119**  
 GUYOT P., AUDIER M., BOISSIEU M. DE  
 Molecular structure of the icosahedral AlLiCu phase. In "Quasicrystals and Incommensurate Structures in Condensed Matter", M.J. Yacaman, D. Romeu, V. Castano, A. Gomez Eds. (World Scientific, 1990) pp. 251-259.

**91MA120**

MA Y., STERN E.A., LI X.-O., JANOT C.  
On the Patterson analysis of aperiodic crystals.  
In "Quasicrystals and incommensurate structures in condensed matter", M.J. Yacaman, D. Romeu, V. Castano, A. Gomez Eds. (World Scientific, 1990) pp. 397-407.

**91RO121**

ROSSAT-MIGNOD J., BURLET P., REGNAULT L.P., VETTIER C.  
Neutron scattering and magnetic phase transitions.  
Journal of Magnetism and Magnetic Materials **90 & 91**, 5-16 (1990).

**91FL122**

FLOUQUET J., HAEN P., LEJAY P., MORIN P., JACCARD D., SCHWEIZER J., VETTIER C., FISHER R.A., PHILLIPS N.E.  
Magnetic instability in Ce heavy fermion compounds.  
Journal of Magnetism and Magnetic Materials **90 & 91**, 377-382 (1990).

**91RE123**

REGNAULT L.P., JACOUD J.L., MIGNOT J.M., ROSSAT-MIGNOD J., VETTIER C., LEJAY P., FLOUQUET J.  
Neutron scattering study of the magnetic-non-magnetic transition in  $Ce_{1-x}La_xRu_2Si_2$ .  
Journal of Magnetism and Magnetic Materials **90 & 91**, 398-400 (1990).

**91BA124**

BALLOU R., DEPORTES J., LEMAIRE R., ROUAULT P., SOUBEYROUX J.L.  
Magnetic ordering in the  $(Y_{1-x}Tb_x)Mn_2$  Laves phases.  
Journal of Magnetism and Magnetic Materials **90 & 91**, 559-560 (1990).

**91BA125**

BALODIS M.K., KRAMER N.D., PROKOFJEV P.T., AFANASJEV A.V., GUSEVA T.V., TAMBERGS J.J., SCHRECKENBACH K., DAVIDSON W.F., WARNER D.D., PINSTON J.A., VAN ASSCHE P.H.M., SPITS A.M.J.  
Level structure of the odd-odd nucleus  $^{156}Eu$ .  
Nuclear Physics **A 523**, 261-299 (1991).

**91BE126**

BECKER G., HAUSEN H.D., MUNDT O., SCHWARZ W., WAGNER C.T., VOGT T.  
Molekül- und Kristallstruktur der Phosphonsäure  $H_3PO_3$ -Röntgen- und Neutronenbeugungsuntersuchungen an der Hydrogen- und der Deuterium-Verbindung.  
Zeitschrift für Anorganische und Allgemeine Chemie **591**, 17-31 (1990).

**91SA127**

SARKISSIAN B.V.B.  
Neutron spin depolarization studies in Au-Fe alloys near the percolation limit.  
Journal of Physics : Condensed Matter **3**, 961-966 (1991).

**91KO128**

KOVATCHEVA D., HEWAT A.W., RANGAVITTAL N., MANIVANNAN V., GURU ROW T.N., RAO C.N.R.  
An x-ray and neutron diffraction study of cation substituted  $TiSr_2CuO_5$ .  
Physica **C 173**, 444-452 (1991).

**91BA129**

BARTHES M., ALMAIRAC R., SAUVAJOL J.L., MORET J., CURRAT R., DIANOUX J.  
Incoherent neutron scattering in acetanilide and three deuterated derivatives.  
Physical Review **B 43**, 5223-5227 (1991).

**91GI130**

GIBBS D., GRUEBEL G., HARSHMAN D.R., ISAACS E.D., MCWHAN D.B., MILLS D., VETTIER C.  
Polarization and resonance studies of x-ray magnetic scattering in holmium.  
Physical Review **B 43**, 5663-5681 (1991).

**91LA131**

LAMOREAUX S.K., GOLUB R., PENDLEBURY J.M.  
Conflict between nulls: Mutual exclusiveness of the search for n-n- oscillations and searches for an antimatter-matter dependence of the gravitational interaction.  
Europhysics Letters **14**, 503-505 (1991).

**91FU132**

FUJARA F., PETRY W., DIEHL R.M., SCHNAUSS W., SILLESCU H.  
Localized motion in supercooled glycerol as measured by  $^2H$ -NMR spin-lattice relaxation and incoherent neutron scattering.  
Europhysics Letters **14**, 563-568 (1991).

**91LE133**

LEBLANC M., FERREY G., LACORRE P., PANNETIER J.  
Ordered magnetic frustration. XII. The magnetic structures of  $Fe_3F_8(H_2O)_2$  at 40 and 2 K.  
Journal of Magnetism and Magnetic Materials **92**, 359-365 (1991).

**91LA134**

LACORRE P., PANNETIER J., LEBLANC M., FERREY G.  
Ordered magnetic frustration. XIII. Monte Carlo simulations of the magnetic behaviour of  $Fe_3F_8(H_2O)_2$ .  
Journal of Magnetism and Magnetic Materials **92**, 366-374 (1991).

**91AL135**

ALONSO J.A., AMADOR J., RASINES I., SOUBEYROUX J.L.  
Er<sub>2</sub>BaNiO<sub>5</sub>: Structure refinement using neutron powder diffraction data.  
*Acta Crystallographica C* **47**, 249-251 (1991).

**91VE136**

VERGNAT M., HOUSSAINI S., DUFOUR C., BRUSON A., MARCHAL G., MANGIN P., ERWIN R., RHYNE J.J., VETTIER C.  
Determination of short-range motion of hydrogen in amorphous silicon multilayers by low-angle neutron scattering.  
*Europhysics Letters* **14**, 457-462 (1991).

**91DI137**

DICAPUA E., RUIGROK R.W.H., TIMMINS P.A.  
Activation of recA protein: The salt-induced structural transition.  
*Journal of Structural Biology* **104**, 91-96 (1990).

**91BA138**

BANASZAK L., TIMMINS P., POLIKS B.J.  
The crystal structure of a lipoprotein: Lipovitellin.  
In "Molecular Biology of Atherosclerosis", A.D. Attie Ed. (Elsevier, 1990) pp. 135-140.

**91JO139**

JOHNSON S.J., BAYERL T.M., MCDERMOTT D.C., ADAM G.W., RENNIE A.R., THOMAS R.K., SACKMANN E.  
Structure of an adsorbed dimyristoylphosphatidylcholine bilayer measured with specular reflection of neutrons.  
*Biophysical Journal* **59**, 289-294 (1991).

**91CR140**

CROWLEY T.L., LEE E.M., SIMISTER E.A., THOMAS R.K., PENFOLD J., RENNIE A.R.  
The application of neutron reflection to the study of layers adsorbed at liquid interfaces.  
*Colloids and Surfaces* **52**, 85-106 (1990).

**91FE141**

FERNANDEZ F., SAEZ-PUCHE R., FERNANDEZ-DIAZ M.T., RODRIGUEZ-CARVAJAL J., MARTINEZ J.L., BOTTO I.L., BARAN E.J.  
Low temperature phase transition of the stoichiometric Ln<sub>2</sub>NiO<sub>4</sub> oxides.  
*European Journal of Solid State and Inorganic Chemistry* **28**, 507-510 (1991).

**91FU142**

FURRER A., ALLENSPACH P., MESOT J., STAUB U., BLANK H., MUTKA H., VETTIER C., KALDIS E., KARPINSKI J., RUSIECKI S., MIRMELSTEIN A.  
Neutron spectroscopic studies of the relation between

superconductivity and the crystal field in high-temperature superconductors.  
*European Journal of Solid State and Inorganic Chemistry* **28**, 627-634 (1991).

**91BO143**

BOURGAUX-LEONARD C., LEGRAND J.F., RENAULT A., DELZENNE P.  
Annealing effects in ferroelectric poly-(vinylidene fluoride-trifluoroethylene) copolymers: real-time studies using synchrotron radiation.  
*Polymer* **32**, 597-604 (1991).

**91DU144**

DUPUY J., JAL J.F., AOUIZERAT-ELARBY A., CARMONA P., DIANOUX A.J., CHIEUX P.  
Vibrational dynamics of liquid and glassy electrolytes.  
In "Hydrogen-Bonded Liquids", J.C. Dore, J. Teixeira Eds. (Kluwer Acad. Publ., 1991) pp. 405-412.

**91SO145**

SONNTAG R., HOHLWEIN D., BRUECKEL T., COLLIN G.  
First observation of superstructure reflections by neutron diffraction due to oxygen ordering in YBa<sub>2</sub>Cu<sub>3</sub>O<sub>6.35</sub>.  
*Physical Review Letters* **66**, 1497-1500 (1991).

**91CO146**

COWLEY R.A., JEHAN D.A., MCMORROW D.F., MCINTYRE G.J.  
Evidence for a devil's staircase in holmium produced by an applied magnetic field.  
*Physical Review Letters* **66**, 1521-1524 (1991).

**91DE147**

ANDRES A. DE, FERNANDEZ-DIAZ M.T., MARTINEZ J.L., RODRIGUEZ-CARVAJAL J., SAEZ-PUCHE R., FERNANDEZ F.  
Raman scattering study of Ln<sub>2</sub>NiO<sub>4+δ</sub> with Ln = La, Pr and Nd.  
*European Journal of Solid State and Inorganic Chemistry* **28**, 179-182 (1991).

**91DO148**

DONG C., DUBOIS J.M., BOISSIEU M. DE, JANOT C.  
Phase transformations and structure characteristics of the Al<sub>65</sub>Cu<sub>17.5</sub>Co<sub>17.5</sub> decagonal phase.  
*Journal of Physics : Condensed Matter* **3**, 1665-1673 (1991).

**91LA149**

LAST J.  
Techniques and results of neutron life time experiments.  
*Neutron News* **2**, n°1, 28-31 (1991).

**91BL150**

BLANK H.  
TOF, backscattering and spin-echo instruments at the ILL.  
Neutron News **2**, n°1, 11-16 (1991).

**91JA151**

JANOT C., DUBOIS J.M., BOISSIEU M. DE  
The structure of quasicrystals: from diffraction patterns  
to atom positions.  
In "Geometry and Thermodynamics", J.C. Tolédano Ed.  
(Plenum Press, 1990) pp. 9-24.

**91SA152**

SADOC J.F., CHARVOLIN J.  
Geometry of films of amphiphile molecules:  
A curved space approach.  
In "Geometry and Thermodynamics", J.C. Tolédano Ed.  
(Plenum Press, 1990) pp. 73-82.

**91CU153**

CURRAT R.  
Phasons and amplitudons in modulated structures.  
In "Geometry and Thermodynamics", J.C. Tolédano Ed.  
(Plenum Press, 1990) pp. 383-386.

**91LA154**

LACORRE P., PANNETIER J., FERREY G.  
Ordered magnetic frustration. XIV. The magnetic structure  
of the tetragonal bronze  $KMnFeF_6$ .  
Journal of Magnetism and Magnetic Materials **94**,  
331-336 (1991).

**91LA155**

LANDER G.H., BROWN P.J., STASSIS C., GOPALAN P.,  
SPALEK J., HONIG G.  
Magnetic and structural study of  $La_{1.8}Sr_{0.2}NiO_4$ .  
Physical Review **B 43**, 448-456 (1991).

**91KO156**

KOVATCHEVA D., STROBEL P., SOULETIE B.,  
HEWAT A.W.  
Structure and oxygen exchange in superconducting  
 $Nd_2Ce_{0.67}Sr_{0.33}BaCu_3O_{9-\delta}$   
Physica C **174**, 280-288 (1991).

**91BA157**

BARUCHEL J., SCHLENKER M., PALMER S.B.  
Neutron diffraction topographic investigations of "exotic"  
magnetic domains.  
Nondestructive Testing and Evaluation **5**, 349-367 (1990).

**91PE158**

PEARCE A., BARUCHEL J., PALMER S.B., SOUSA J.B.  
Silicon gradient related phase coexistence in Cr-Si ?  
Nondestructive Testing and Evaluation **5**, 369-377 (1990).

**91FJ159**

FJELLVAG H., CHRISTENSEN A.N., PANNETIER J.  
Formation and structural properties of  $SbTaO_4$ .  
Acta Chemica Scandinavica **44**, 975-977 (1990).

**91JA160**

JANOT C., AUDIER M., BOISSIEU M. DE, DUBOIS J.M.  
Al-Cu-Fe quasi-crystals: Low-temperature unstability via a  
modulation mechanism.  
Europhysics Letters **14**, 355-360 (1991).

**91BE161**

BERMEJO F.J., ALVAREZ M., GARCIA-HERNANDEZ  
M., MOMPEAN F., WHITE R.P., HOWELLS W.S.,  
CARLILE C.J., ENCISO E., BATALLAN F.  
Dynamics of liquid  $CCl_4$  from quasi-elastic neutron  
scattering.  
Journal of Physics : Condensed Matter **3**, 851-863 (1991).

**91WE162**

WENK H.R., PANNETIER J.  
Texture development in deformed granodiorites from the  
Santa Rosa mylonite zone, southern California.  
Journal of Structural Geology **12**, 177-184 (1990).

**91BO163**

BOENI P., GOERLITZ D., KOETZLER J.,  
MARTINEZ J.L.  
Dynamics of longitudinal and transverse fluctuations above  
 $T_C$  in EuS.  
Physical Review **B 43**, 8755-8758 (1991).

**91RO164**

RODRIGUEZ F., GOMEZ SAL J.C., MORENO M.,  
GEYER A. DE, JANOT C.  
Determination of the shape and size of aggregated phases  
in  $NaCl:Mn^{2+}$  by small-angle neutron scattering.  
Physical Review **B 43**, 7519-7526 (1991).

**91PR165**

PRICE D.L., SABOUNGI M.L., REIJERS R., KEARLEY  
G., WHITE R.  
Two-stage melting in cesium lead alloys.  
Physical Review Letters **66**, 1894-1897 (1991).

**91PI166**

PIERRON-BOHNES V., CADEVILLE M.C., FINEL A.,  
SCHAERPF O.  
Influence of magnetism on chemical order  
in a  $FeAl_{19.5}$  at % single crystal. High temperature  
measurements of neutron diffuse scattering.  
Journal de Physique I **1**, 247-260 (1991).

**91NE167**

NEILSON G.W.  
The structure of aqueous electrolyte solutions : Comparison  
of computer simulation and experiment.  
Zeitschrift für Naturforschung **46a**, 100-106 (1991).

**91CH168**

CHAILLOUT C., CHMAISSEN O., CAPPONI J.J.,  
FOURNIER T., MCINTYRE G.J., MAREZIO M.

The structure of superconducting  
 $\text{Pb}_2\text{Sr}_2\text{Y}_{0.73}\text{Ca}_{0.27}\text{Cu}_3\text{O}_8$  by single crystal neutron  
diffraction.  
*Physica C* **175**, 293-300 (1991).

**91GR169**

GRUEBEL G., AXE J.D., GIBBS D., LANDER G.H.,  
MARMEGGI J.C., BRUECKEL T.

Incommensurate charge-density-wave state in  $\alpha$ -uranium :  
A high-resolution x-ray and neutron-scattering study.  
*Physical Review B* **43**, 8803-8807 (1991).

**91RU170**

RUEDLINGER M., SCHEFER J., CHEVRIER G., FURER  
N., GUEDEL H.U., HAUSSUEHL S., HEGER G.,  
SCHWEISS P., VOGT T., WOIKE T., ZOELLNER H.

Light-induced structural changes in sodiumnitroprusside  
( $\text{Na}_2(\text{Fe}(\text{CN})_5\text{NO}) \cdot 2\text{D}_2\text{O}$ ) at 80 K.  
*Zeitschrift für Physik B* **83**, 125-130 (1991).

**91MA171**

MARET M., CHIEUX P., DUBOIS J.M., PASTUREL A.  
Composition dependence of topological and chemical orders  
in liquid  $\text{Al}_{1-x}(\text{Mn}_y(\text{FeCr})_{1-y})_x$  alloys by neutron diffraction.  
*Journal of Physics : Condensed Matter* **3**, 2801-2817 (1991).

**91LA172**

LACORRE P., TORRANCE J.B., PANNETIER J.,  
NAZZAL A.I., WANG P.W., HUANG T.C.

Synthesis, crystal structure, and properties of metallic  
 $\text{PrNiO}_3$  : Comparison with metallic  $\text{NdNiO}_3$  and  
semiconducting  $\text{SmNiO}_3$ .  
*Journal of Solid State Chemistry* **91**, 225-237 (1991).

**91BO173**

BONNEAU P., GARNIER P., CALVARIN G., HUSSON  
E., GAVARRI J.R., HEWAT A.W., MORELL A.

X-ray and neutron diffraction studies of the diffuse phase  
transition in  $\text{PbMg}_{1/3}\text{Nb}_{2/3}\text{O}_3$  ceramics.  
*Journal of Solid State Chemistry* **91**, 350-361 (1991).

**91HE174**

HELLMANN E.H., HELLMANN G.P., RENNIE A.R.  
Solvent-induced phase separation in polycarbonate blends  
PC/TMPC.

*Colloid and Polymer Science* **269**, 343-352 (1991).

**91UL175**

ULBIG S., LIEB K.P., BOERNER H.G., KRUSCHE B.,  
ROBINSON S.J., BOOTEN J.G.L.

GRID lifetime measurements in  $^{59}, ^{61}, ^{63}\text{Ni}$  following  
thermal neutron capture.  
*Zeitschrift für Physik A* **338**, 397-404 (1991).

**91PE176**

PETRY W., BARTSCH E., FUJARA F., KIEBEL M.,  
SILLESU H., FARAGO B.

Dynamic anomaly in the glass transition region of  
orthoterphenyl. A neutron scattering study.  
*Zeitschrift für Physik B* **83**, 175-184 (1991).

**91BU177**

BUTERA R., FETTERS L.J., HUANG J.S., RICHTER D.,  
PYCKHOUT-HINTZEN W., ZIRKEL A., FARAGO B.,  
EWEN B.

Microscopic and macroscopic evaluation of fundamental  
facets of the entanglement concept.  
*Physical Review Letters* **66**, 2088-2091 (1991).

**91UL178**

ULBIG S., JOLIE J., ROBINSON S.J., LIEB K.P.,  
BOERNER H.G., SCHILLEBEECKX P.

GRID lifetime study of the reaction  $^{35}\text{Cl}(n,\gamma)^{36}\text{Cl}$  and the  
slowing-down process of 0.5 keV Cl atoms in chlorides.  
*Physics Letters B* **259**, 29-33 (1991).

**91SC179**

SCHAUPERT K., ALBRECHT D., ARMBRUSTER P.,  
SPOHR R.

Permeation through latent nuclear tracks in polymer foils.  
*Applied Physics A* **44**, 347-352 (1987).

**91ST180**

STUESSER N., SONNTAG R., HOHLWEIN D., ZEISKE  
T., HOSER A., KEMMLER-SACK S., FRIES T., VOGT T.

Crystallographic and magnetic structures of high  $T_c$  related  
( $\text{Bi/Pb}$ ) $_2\text{Sr}_2\text{FeO}_{6.25}$  determined by neutron powder  
diffraction.  
*Zeitschrift für Physik B* **83**, 165-170 (1991).

**91GO181**

GODFRIN H., RAPP R.E., LAUTER H.J.

Magnetic behavior of  $^3\text{He}$  films.  
*Physica B* **169**, 177-182 (1991).

**91SC182**

SCHOPOHL N., WAXMAN D.

Quasiclassical theory of the A-B phase boundary  
of superfluid  $^3\text{He}$ .  
*Physica B* **169**, 165-169 (1991).

**91RO183**

ROSSAT-MIGNOD J., REGNAULT L.P., VETTIER C.,  
BURLET P., HENRY J.Y., LAPERTOT G.,

Investigation of the spin dynamics in  $\text{YBa}_2\text{Cu}_3\text{O}_{6+x}$   
by inelastic neutron scattering.  
*Physica B* **169**, 58-65 (1991).

**91CH184**

CHARVOLIN J.

Lytotropic liquid crystals as structures of defects.  
Molecular Crystals and Liquid Crystals **198**, 145-157 (1991).  
(Molecular Crystals and Liquid Crystals Bulletin **6**, 26 (1991)).

**91DU185**

DURAND D., PAPOULAR R., CURRAT R., LAMBERT M., LEGRAND J.F., MEZEI F.

Investigation of the incommensurate transition of sodium nitrite by the neutron spin-echo technique.  
Physical Review **B 43**, 10690-10696 (1991).

**91OB186**

OBRADORS X., BATLLE X., RODRIGUEZ-CARVAJAL J., MARTINEZ J.L., VALLET M., GONZALEZ-CALBET J., ALONSO J.

Magnetic transitions in Nd<sub>2</sub>NiO<sub>4</sub>.  
Physical Review **B 43**, 10451-10454 (1991).

**91TR187**

TRAMPENAU J., HEIMING A., PETRY W., ALBA M., HERZIG C., MIEKELEY W., SCHOBER H.R.

Phonon dispersion of the bcc phase of group-IV metals. III. bcc hafnium.  
Physical Review **B 43**, 10963-10969 (1991).

**91HE188**

HEIMING A., PETRY W., TRAMPENAU J., ALBA M., HERZIG C., SCHOBER H.R., VOGL G.

Phonon dispersion of the bcc phase of group-IV metals. II. bcc zirconium, a model case of dynamical precursors of martensitic transitions.  
Physical Review **B 43**, 10948-10962 (1991).

**91PE189**

PETRY W., HEIMING A., TRAMPENAU J., ALBA M., HERZIG C., SCHOBER H.R., VOGL G.

Phonon dispersion of the bcc phase of group-IV metals. I. bcc titanium.  
Physical Review **B 43**, 10933-10947 (1991).

**91SU190**

SUCK J.B.

Atomic dynamics of metallic glasses and icosahedral alloys (quasicrystals).  
Materials Science and Engineering **A 133**, 40-44 (1991).

**91MA191**

MATULL R., ESCHKOETTER P., RUPP R.A., IBEL K.

Perfect crystallike gratings for cold neutrons.  
Europhysics Letters **15**, 133-137 (1991).

**91HO192**

HORKAY F., HECHT A.M., MALLAM S., GEISSLER E., RENNIE A.R.

Macroscopic and microscopic thermodynamic observations in swollen poly(vinyl acetate) networks.  
Macromolecules **24**, 2896-2902 (1991).

**91AL193**

ALEKSEEV P.A., LAZUKOV V.N., ORLOV V.G., SADIKOV I.P., SUCK J.B., KOTUNOV V.V.

Inelastic neutron magnetic scattering from amorphous and polycrystalline PrNi<sub>5</sub>.  
Europhysics Letters **15**, 29-35 (1991).

**91WO194**

WOOD M.J., YAU P., IMAI B.S., GOLDBERG M.W., LAMBERT S.J., FOWLER A.G., BALDWIN J.P., GODFREY J.E., MOUDRIANAKIS E.N., KOCH M.H.J., IBEL K., MAY R.P., BRADBURY E.M.

Neutron and x-ray scatter studies of the histone octamer and amino and carboxyl domain trimmed octamers.  
The Journal of Biological Chemistry **266**, 5696-5702 (1991).

**91SO195**

SOURISSEAU C., FOUASSIER M., ALBA M., GHORAYEB A., GOROCHOV O.

Resonance Raman, inelastic neutron scattering and lattice dynamics studies of 2H-WS<sub>2</sub>.  
Materials Science and Engineering **B 3**, 119-123 (1989).

**91BE196**

BERNHOFET N.R., ALLEN P.J., PAUL D.MCK., HAYDEN S.M., TIMMINS P.A., LONZARICH G.G.

Anomalous neutron scattering near the superconducting phase transition.  
Nature **350**, 690-692 (1991).

**91GA197**

GASKELL P.H., ECKERSLEY M.C., BARNES A.C., CHIEUX P.

Medium-range order in the cation distribution of a calcium silicate glass.  
Nature **350**, 675-677 (1991).

**91CH198**

CHIEUX P., DORE J.C.

Neutron diffraction techniques.  
In "Hydrogen-Bonded Liquids", J.C. Dore, J. Teixeira Eds. (Kluwer Academic Publishers, 1991) pp. 101-116.

**91TU199**

TUCK J.J., ROSS D.K., LI J.C., SARKISSIAN B. SANS and QENS studies of Vycor containing D<sub>2</sub>O/H<sub>2</sub>O mixtures.

In "Hydrogen-Bonded Liquids", J.C. Dore, J. Teixeira Eds. (Kluwer Academic Publishers, 1991) pp. 159-170.

**91JA200**

JANOT C., BOISSIEU M. DE, DUBOIS J.M.  
Quasicrystal structures with neutron diffraction: How far from 3-dim Penrose lattices.  
*Physica Scripta* **T35**, 95-102 (1991).

**91FI201**

FISCHER K.H., NATTERMANN T.  
Collective flux creep in high- $T_c$  superconductors.  
*Physical Review* **B 43**, 10372-10382 (1991).

**91DU202**

DUVAL M., PICOT C., BENOIT H., BORSALI R., BENMOUNA M., LARTIGUE C.  
Spin-echo neutron scattering from copolymers in intermediate solvents.  
*Macromolecules* **24**, 3185-3188 (1991).

**91RO203**

RODRIGUEZ V., COUZI M., SOURISSEAU C.  
Valence force fields of the ordered fluoride  $\text{CoZrF}_6$  in the cubic and rhombohedral phases.  
*Journal of Physics and Chemistry of Solids* **52**, 769-777 (1991).

**91MA204**

MARTINEZ J.L., FERNANDEZ-DIAZ M.T., RODRIGUEZ-CARVAJAL J., ODIER P.  
Lattice instability and low-temperature phase transition in  $\text{Pr}_2\text{NiO}_4$ .  
*Physical Review* **B 43**, 13766-13769 (1991).

**91MA205**

MARTINEZ J.L., BERMEJO F.J., GARCIA-HERNANDEZ M., MOMPEAN F.J., ENCISO E., MARTIN D.  
Collective excitations in a dense dipolar fluid studied by inelastic neutron scattering.  
*Journal of Physics : Condensed Matter* **3**, 4075-4087 (1991).

**91HO206**

HODGE D.J., LAUGHLIN R.G., OTTEWILL R.H., RENNIE A.R.  
Micellization of ultralong chain surfactants.  
*Langmuir* **7**, 878-884 (1991).

**91CA207**

CANNON R.D., JAYASOORIYA U.A., ARAPKOSKE S.K., WHITE R.P., WILLIAMS J.H.  
Phase transitions in  $[\text{Fe}_3\text{O}(\text{OCCD}_3)_6(\text{C}_5\text{H}_5\text{N})_3](\text{C}_5\text{H}_5\text{N})$ : Evidence from incoherent neutron scattering.  
*Journal of the American Chemical Society* **113**, 4158-4160 (1991).

**91DU208**

DUBBERS D.  
Tests of the standard model with free neutron beta decay.  
*Nuclear Physics A* **527**, 239c-250c (1991).

**91LI209**

LINDNER P.  
Small angle neutron scattering studies of liquid systems in nonequilibrium.  
*Physica A* **174**, 74-93 (1991).

**91TR210**

TRUMP R., THIERFELDT S., LOEWENHAUPT M., CHATTOPADHYAY T.  
Magnetic structure of the Kondo lattice compound  $\text{CeCu}_2$ .  
*Journal of Applied Physics* **69**, 4699-4701 (1991).

**91HA211**

HANLEY H.J.M., STRATY G.C., LINDNER P.  
Order in a simple colloidal mixture suspension.  
*Physica A* **174**, 60-73 (1991).

**91TI212**

TIMMINS P.A., HAUK J., WACKER T., WELTE W.  
The influence of heptane-1,2,3-triol on the size and shape of LDAO micelles. Implications for the crystallization of membrane proteins.  
*FEBS* **280**, 115-120 (1991).

**91DE213**

DEPMEIER W., VOGT T., BUEHRER W.  
X-ray and neutron investigations on the intermediate phase of the  $\text{Ca-WO}_4$  aluminate sodalite CAW.  
*Phase Transitions* **32**, 211-214 (1991).

**91JA214**

JANOT C.  
The structure of quasicrystals.  
*Neutron News* **2**, n° 2, 23-26 (1991).

**91PA215**

PAVLOV M.Y., RUBLEVSKAYA I.N., SERDYUK I.N., ZACCAI G., LEBERMAN R., OSTANEVICH Y.M.  
Experimental verification of the triple isotopic substitution method in small-angle neutron scattering.  
*Journal of Applied Crystallography* **24**, 243-254 (1991).

**91BR216**

BROWN P.J., CHATTOPADHYAY T., FORSYTH J.B., NUNEZ V., TASSET F.  
Antiferromagnetism in  $\text{CuO}$  studied by neutron polarimetry.  
*Journal of Physics : Condensed Matter* **3**, 4281-4287 (1991).

**91VE217**

VERKHOVSKAYA K.A., BUNE A.V., FRIDKIN V.M., LEGRAND J.F.  
Optical sensitization at the phase transition in the ferroelectric vinylidene fluoride-trifluoroethylene copolymer.  
*Applied Physics Letters* **57**, 2532-2533 (1990).

**91WI218**

WICKER A., LOTZ B., WITTMANN J.C., LEGRAND J.F.  
Electron microscope studies of ferroelectric domain structures of triglycine sulphate crystals using polymer decoration.  
*Polymer Communications* **30**, 251-253 (1989).

**91DE219**

DEGIORGIO V., CORTI M., PIAZZA R., CANTU L., RENNIE A.R.  
Small-angle neutron-scattering study of concentrated nonionic-amphiphile solutions.  
*Colloid and Polymer Science* **269**, 501-505 (1991).

**91TE220**

TERECH P.  
Small-angle-scattering study of 12-hydroxystearic physical organogels and lubricating greases.  
*Colloid and Polymer Science* **269**, 490-500 (1991).

**91BA221**

BARUCHEL J., BOUILLOT J., COQUET E.  
Investigation of the effect of an applied electric field on  $\alpha$ -LiIO<sub>3</sub> crystals by synchrotron radiation topography.  
*Philosophical Magazine* **B 63**, 1051-1062 (1991).

**91CO222**

COCKCROFT J.K., FITCH A.N.  
The structure of solid dichlorodifluoromethane CF<sub>2</sub>Cl<sub>2</sub> by powder neutron diffraction.  
*Zeitschrift für Kristallographie* **197**, 121-130 (1991).

**91NE223**

NEUMANN K.U., BROWN P.J., CAPELLMANN H., ZIEBECK K.R.A., SMITH J.L., FISK Z., FRANSE J.J.M., MENOVSKY A.  
A comparison of the static magnetic field induced magnetisation densities in UPt<sub>3</sub> and UBe<sub>13</sub>.  
*Physica* **B 171**, 273-277 (1991).

**91AL224**

ALLENSPACH P., MESOT J., STAUB U., FURRER A., BLANK H., MUTKA H., VETTIER C., KALDIS E., KARPINSKI J., RUSIECKI S.  
The crystalline electric field as a direct probe for charge transfer processes in high-temperature superconductors.  
*Physica* **B 171**, 269-272 (1991).

**91FI225**

FILLAUX F., LAUTIE A., TOMKINSON J., KEARLEY G.J.  
Proton transfer dynamics in the hydrogen bond. Inelastic neutron scattering, infrared and Raman spectra of Na<sub>3</sub>H(SO<sub>4</sub>)<sub>2</sub>, K<sub>3</sub>H(SO<sub>4</sub>)<sub>2</sub> and Rb<sub>3</sub>H(SO<sub>4</sub>)<sub>2</sub>.  
*Chemical Physics* **154**, 135-144 (1991).

**91MA226**

MALAMAN B., IJJAALI M., VENTURINI G., GLEITZER C., SOUBEYROUX J.L.  
Neutron diffraction study of Fe<sub>4</sub>(PO<sub>4</sub>)<sub>3</sub>(OH)<sub>3</sub> : Occurrence of ferromagnetic Fe<sub>2</sub>O<sub>9</sub> clusters.  
*European Journal of Solid State and Inorganic Chemistry* **28**, 519-531 (1991).

**91HE227**

HELLMANN E.H., HELLMANN G.P., RENNIE A.R.  
Chain fragment diffusion in liquid and glassy polymer blends.  
*Macromolecules* **24**, 3821-3827 (1991).

**91CH228**

CHRISTENSEN A.N., HAZELL R.G., HEWAT A.W., O'REILLY K.P.J.  
The crystal structure of PbS<sub>2</sub>O<sub>3</sub>.  
*Acta Chemica Scandinavica* **45**, 469-473 (1991).

**91AI229**

AIME J.P., GARRIN P., BAKER G.L., RAMAKRISHNAN S., TIMMINS P.  
Physical origin of the local rigidity of conjugated polymers in good solvent.  
*Synthetic Metals* **41-43**, 859-867 (1991).

**91JO230**

JONES D.L., STIRLING W.G., LANDER G.H., REBIZANT J., SPIRLET J.C., ALBA M., VOGT O.  
Neutron scattering study of single crystals of NpAs and NpSb.  
*Journal of Physics : Condensed Matter* **3**, 3551-3562 (1991).

**91SA231**

SALINAS-SANCHEZ A., SAEZ-PUCHE R., RODRIGUEZ-CARVAJAL J., MARTINEZ J.L.  
Structural characterization of R<sub>2</sub>BaNiO<sub>5</sub> (R=Tm and Yb): Polymorphism for R=Tm.  
*Solid State Communications* **78**, 481-488 (1991).

**91RO232**

RODRIGUEZ-CARVAJAL J., FERNANDEZ-DIAZ M.T., MARTINEZ J.L.  
Neutron diffraction study on structural and magnetic properties of La<sub>2</sub>NiO<sub>4</sub>.  
*Journal of Physics : Condensed Matter* **3**, 3215-3234 (1991).

**91MA233**

MALLAM S., HORKAY F., HECHT A.M., RENNIE A.R., GEISSLER E.  
Microscopic and macroscopic thermodynamic observations in swollen poly(dimethylsiloxane) networks.  
*Macromolecules* **24**, 543-548 (1991).

**91AN234**

ANDRES A. DE, FERNANDEZ-DIAZ M.T., MARTINEZ J.L., RODRIGUEZ-CARVAJAL J., SAEZ-PUCHE R., FERNANDEZ F.  
Raman scattering of orthorhombic and tetragonal  $\text{Ln}_2\text{NiO}_{4+\delta}$  (Ln=La,Pr,Nd) oxides.  
Journal of Physics : Condensed Matter **3**, 3813-3823 (1991).

**91MA235**

MARTINEZ J.L., BERMEJO F.J., GARCIA-HERNANDEZ M., MOMPEAN F.J.  
Evidence for magnetic excitations in liquid oxygen.  
Journal of Physics : Condensed Matter **3**, 3849-3853 (1991).

**91DE236**

DEBUS O., ZIMMERMANN H., BARTSCH E., FUJARA F., KIEBEL M., PETRY W., SILLESCU H.  
Comparative study of the Debye-Waller factor anomaly at the glass transition of isotopically substituted orthoterphenyls.  
Chemical Physics Letters **180**, 271-274 (1991).

**91BL237**

BLAND J.A.C., JOHNSON A.D., LAUTER H.J., BATESON R.D., BLUNDELL S.J., SHACKLETON C., PENFOLD J.  
Spin-polarised neutron reflection studies of epitaxial films.  
Journal of Magnetism and Magnetic Materials **93**, 513-522 (1991).

**91BL238**

BLAND J.A.C., BATESON R.D., JOHNSON A.D., HEINRICH B., CELINSKI Z., LAUTER H.J.  
Magnetic properties of ultrathin bcc Fe(001) films grown epitaxially on Ag(001) substrates.  
Journal of Magnetism and Magnetic Materials **93**, 331-335 (1991).

**91MA239**

MARTINEZ J.L., CEBOLLADA A., GALLEGO J.M., MIGUEL J.J. DE, OCAL C., MIRANDA R., FERRER S., FILLION G., REBOUILLAT J.P.  
Neutron-diffraction study on the field dependent magnetic ordering in Co-Cu superlattices.  
Journal of Magnetism and Magnetic Materials **93**, 89-94 (1991).

**91BL240**

BLAND J.A.C., BATESON R.D., RIEDI P.C., GRAHAM R.G., LAUTER H.J., PENFOLD J., SHACKLETON C.  
Magnetic properties of bcc Co films.  
Journal of Applied Physics **69**, 4989-4991 (1991).

**91LA241**

LANDER G.H., BROWN P.J., STASSIS C., GOPALAN P., SPALEK J., HONIG G.  
Neutron and magnetization study of  $\text{La}_{1.8}\text{Sr}_{0.2}\text{NiO}_4$ .  
Journal of Applied Physics **69**, 4869-4871 (1991).

**91LA242**

LANDER G.H., BROOKS M.S.S., LEBECH B., BROWN P.J., VOGT O., MATTENBERGER K.  
Measurement of anisotropy constant in US with polarized neutrons.  
Journal of Applied Physics **69**, 4803-4805 (1991).

**91AE243**

AEBERSOLD M.A., BLANK H., BRIAT B., FURRER A., GUEDEL H.U.  
Inelastic neutron scattering and optical absorption spectroscopy of the  $\text{Ti}^{2+}(\text{Mn}^{2+})_6$  spin cluster in  $\text{Ti}^{2+}$ -doped  $\text{MnBr}_2$  and  $\text{MnCl}_2$ .  
Inorganic Chemistry **30**, 3556-3562 (1991).

**91RO244**

RODMACQ B., MANGIN P., VETTIER C.  
Evidence for antiferromagnetic coupling in Ag/Ni superlattices: a neutron scattering study.  
Europhysics Letters **15**, 503-507 (1991).

**91BE245**

BERMEJO F.J., MARTINEZ J.L., GARCIA-HERNANDEZ M., MARTIN D., MOMPEAN F.J., ALONSO J., HOWELLS W.S.  
Collective low-frequency excitations in a molecular glass.  
Europhysics Letters **15**, 509-514 (1991).

**91RO246**

ROSSEINSKY M.J., PRASSIDES K., DAY P.  
Magnetic order and crystal chemistry of  $\text{Nd}_{2-x}\text{Ce}_x\text{CuO}_{4-\delta}$   
Inorganic Chemistry **30**, 2680-2687 (1991).

**91PR247**

PRATT F.L., DOPORTO M., HAYES W., SINGLETON J., JANNSEN T., KURMOO M., DAY P.  
Magnetotransport studies of  $(\text{BEDT-TTF})_2\text{Cu}(\text{SCN})_2$ .  
Synthetic Metals **41-43**, 2195-2198 (1991).

**91KU248**

KURMOO M., KANAZAWA D., DAY P.  
EPR of BEDT-TTF salts containing magnetic anions,  $\text{Cu}^{\text{II}}\text{X}_4^{2-}$ , X = Cl or Br.  
Synthetic Metals **41-43**, 2123-2126 (1991).

**91KU249**

KURMOO M., ALLAN M., FRIEND R.H., CHASSEAU D., BRAVIC G., DAY P.  
 $(\text{BEDT-TTF})_2\text{GaCl}_4$ : Structure, electrical and magnetic properties.  
Synthetic Metals **41-43**, 2127-2130 (1991).

**91MA250**

MARSDEN I.R., OBERTELLI S.D., ALLAN M.L., FRIEND R.H., KURMOO M., ROSSEINSKY M.J., DAY P.  
Electronic and magnetic properties of a triflate salt of BEDT-TTF,  $(\text{BEDT-TTF})_2\text{CF}_3\text{SO}_3$ .  
Synthetic Metals **41-43**, 2151-2154 (1991).

**91KA251**

KAMITAKAHARA W.A., CAPPELLETTI R.L.,  
BOOLCHAND P., HALFPAP B., GOMPF F., NEUMANN  
D.A., MUTKA H.

Vibrational densities of states and network rigidity in  
chalcogenide glasses.

Physical Review **B 44**, 94-100 (1991).

**91GA252**

GAGLIANO E.R., BALSEIRO C.A., AVIGNON M.

Ground-state and elementary excitations in high- $T_c$

materials.

Europhysics Letters **12**, 259-265 (1990).

**91CO253**

COEY J.M.D., BALLEST O., BAKAS T., MANGIN P.

Spin-glass properties of a planar antiferromagnet.

Journal of Applied Physics **67**, 5258-5260 (1990).

**91BL254**

BLAND J.A.C., JOHNSON A.D., NORRIS C., LAUTER H.J.

Absolute value of the magnetic moment per atom in  
Ag/Fe/Ag(001) and Ag/Co/Ag(001) epitaxial sandwich  
structures.

Journal of Applied Physics **67**, 5397-5399 (1990).

**91FI255**

FITCH A.N., COCKCROFT J.K.

A new structure for the lowest-temperature phase of solid  
hydrogen sulphide.

Journal of the Chemical Society. Chemical Communications  
515-516 (1990).

**91GU256**

GUITTER E., LEIBLER S., MAGGS A.C., DAVID F.

Stretching and buckling of polymerized membranes: a  
Monte Carlo study.

Journal de Physique **51**, 1055-1060 (1990).

**91DO257**

DORNER B., STRAUCH D.

Phonon dispersion sheets and group velocities in GaAs.

Journal of Physics : Condensed Matter **2**, 1475-1483 (1990).

**91GO258**

GODFRIN H., RAPP R.E., OSHEROFF D.D.

Helium three model systems of magnetism.

Physica A **163**, 101-110 (1990).

**91TI259**

TIMMINS P.A., RUIGROK R.W.H., DICAPUA E.

The solution structure of recA filaments by small angle  
neutron scattering.

Biochimie **73**, 227-230 (1991).

**91PE260**

PETRY W.

Phonons at martensitic phase transitions of bcc-Ti,  
bcc-Zr and bcc-Hf.

Phase Transitions **31**, 119-136 (1991).

**91ST261**

STEINER T., MASON S.A., SAENGER W.

Disordered guest and water molecules. Three-center  
and flip-flop O-H...O hydrogen bonds in crystalline  
 $\beta$ -cyclodextrin ethanol octahydrate at  $T = 295$  K:  
A neutron and X-ray diffraction study.

Journal of the American Chemical Society **113**,  
5676-5687 (1991).

**91MU262**

MUTKA H., PAYEN C., MOLINIE P., SOUBEYROUX  
J.L., COLOMBET P., TAYLOR A.D.

Dynamic structure factor ( $S(Q,\omega)$ ) of the  $S = 1$  quasi-one-  
dimensional Heisenberg antiferromagnet : Neutron-  
scattering study on AgVP<sub>2</sub>S<sub>6</sub>.

Physical Review Letters **67**, 497-500 (1991).

**91WI263**

WILKINSON C., LAUTENSCHLAEGER G.,  
HOCK R., WEITZEL H.

Determination of the direction of the propagation vector for  
incommensurate structures from neutron powder diffraction  
patterns.

Journal of Applied Crystallography **24**, 365-368 (1991).

**91NA264**

NASTOLL H., SCHRECKENBACH K., BAGLIN C.,  
BUSSIÈRE A., GUILLAUD J.P., KOSSAKOWSKI R.,  
LIAUD P.

Precise determination of the degree of polarization  
of a cold neutron beam.

Nuclear Instruments and Methods in Physics Research  
A **306**, 65-72 (1991).

**91CH265**

CHARVOLIN J., SADOUC J.F.

Lyotropic liquid crystals : The common skeleton of their  
phase diagrams.

Physica A **176**, 138-150 (1991).

**91GI266**

GINGRAS M.J.P., HOLDSWORTH P.C.W., BERGERSEN B.

Induced nearest-neighbor bond orientational ordering  
and structural transformation in a two-dimensional liquid  
crystal model.

Molecular Crystals and Liquid Crystals Bulletin **6**,  
166 (1991).

**91BA267**

BAUMANN J., KALUS J., HOFFMANN H., THUNIG C., LINDNER P.

Small angle neutron scattering measurements on iridescent surfactant solutions.

Berichte der Bunsengesellschaft für Physikalische Chemie **95**, 795-801 (1991).

**91GA268**

GAY J.M., SUZANNE J., DASH J.G., LAUTER H.J.

Evolution of multilayer Ar films on graphite below and above the bulk triple point: a neutron diffraction study.

Journal de Physique I **1**, 1279-1290 (1991).

**91MA269**

MAGLI R., FREDRIKZE H., CHIEUX P., BAROCCHI F.

Three-body effects from the density dependence of the neutron structure factor of gaseous  $^{36}\text{Ar}$  at 140 K.

Europhysics Letters **15**, 609-614 (1991).

**91DO270**

DOENNI A., FISCHER P., FURRER A., COCKCROFT J.K., GUEDEL H.U.

Temperature-dependent structure and anisotropic Debye-Waller factors of the dimer compounds  $\text{Cs}_3\text{Ho}_2\text{Br}_9$ .

Journal of Solid State Chemistry **93**, 119-127 (1991).

**91FA271**

FARLEY T.W.D., HAYES W., HULL S., HUTCHINGS M.T., VRTIS M.

Investigation of thermally induced  $\text{Li}^+$  ion disorder in  $\text{Li}_2\text{O}$  using neutron diffraction.

Journal of Physics : Condensed Matter **3**, 4761-4781 (1991).

**91RO272**

ROSSEINSKY M.J., PRASSIDES K., DAY P.

$\text{La}_{2-x}\text{Sr}_x\text{CuO}_{4-\delta}$ : Structural, magnetic and transport measurements on antiferromagnets, insulators and superconductors.

Journal of Materials Chemistry **1**, 597-610 (1991).

**91CH273**

CHATTOPADHYAY T., BROWN P.J., KOEBLER U.

Crystal and magnetic structure of  $\text{Nd}_2\text{CuO}_4$  at millikelvin temperatures.

Physica **C 177**, 294-296 (1991).

**91DO274**

DOSTER W., CUSACK S., PETRY W.

Structural dynamics of proteins, scaling behaviour and liquid glass transition.

Journal of Non-Crystalline Solids **131-133**, 357-361 (1991).

**91FR275**

FRICK B., ZORN R., RICHTER D., FARAGO B.

Investigation of the glass transition in polymers under the aspect of mode coupling predictions.

Journal of Non-Crystalline Solids **131-133**, 169-176 (1991).

**91DI276**

DIANOUX A.J., TACHEZ M., MERCIER R., MALUGANI J.P.

Neutron scattering by superionic conductor glasses.

Journal of Non-Crystalline Solids **131-133**, 973-980 (1991).

**91EW277**

EWEN B., RICHTER D., FETTERS L.J., HUANG J.S., FARAGO B.

Neutron scattering studies on the relation between structure and dynamics of star-shaped polymers.

Journal of Non-Crystalline Solids **131-133**, 697-702 (1991).

**91RI278**

RICHTER D., FETTERS L.J., HUANG J.S., FARAGO B., EWEN B.

Neutron spin-echo investigations on the dynamics of polymer systems.

Journal of Non-Crystalline Solids **131-133**, 604-611 (1991).

**91HE279**

HEWAT A.W.

Relations between superconductivity and structure obtained by neutron diffraction.

Physica Scripta **44**, 38-50 (1991).

**91BA280**

BAUSENWEIN T., BERTAGNOLLI H., TOEDHEIDE K., CHIEUX P.

Determination of the structure of fluid deuterium chloride by neutron diffraction at high pressure.

Berichte der Bunsengesellschaft für Physikalische Chemie **95**, 577-584 (1991).

**91BA281**

BANASZAK L., SHARROCK W., TIMMINS P.

Structure and function of a lipoprotein: Lipovitellin.

Annual Review of Biophysics and Biophysical Chemistry **20**, 221-246 (1991).

**91AL282**

ALBIGES-RIZO C., BARGE A., RUIGROK R.W.H., TIMMINS P.A., CHROBOCZEK J.

Human adenovirus serotype 3 fiber protein. Comparison of native and recombinant proteins.

Journal of Biological Chemistry **266**, 3961-3967 (1991).

**91SA283**

SAUVAJOL J.L., DJURADO D., DIANOUX A.J., THEOPHILOU N., FISCHER J.E.

Polarized vibrational density of states of polyacetylene from incoherent inelastic neutron scattering.

Physical Review **B 43**, 14305-14308 (1991).

**91BO284**

BOERNER H.G., JOLIE J.

Ultra-high resolution  $\gamma$ -ray spectroscopy and its application to the determination of  $\gamma$ -ray induced Doppler broadening.

Nuclear Physics News **1**, n°4, 14-16 (1991).

**91CZ285**

CZYZEK M., FUESS H., VOGT T.  
Structural evidence for  $\Pi$  complexes in catalytically active Y zeolites with *o*-, *m*-, and *p*-xylene.  
Journal of Physical Chemistry **95**, 5255-5261 (1991).

**91MA286**

MAY R.P.  
Label triangulation.  
In "Neutron, X-ray and Light Scattering", P. Lindner, T. Zemb Eds. (Elsevier Science Publ. 1991) pp. 119-133.

**91LI287**

LINDNER P.  
Steady-state SANS experiments under external constraints. The example of dilute polymer solutions in laminar shear flow.  
In "Neutron, X-ray and Light Scattering", P. Lindner, T. Zemb Eds. (Elsevier Science Publ. 1991) pp. 261-278.

**91BA288**

BATLLE X., OBRADORS X., RODRIGUEZ-CARVAJAL J., PERNET M., CABANAS M.V., VALLET M.  
Cation distribution and intrinsic magnetic properties of Co-Ti-doped *M*-type barium ferrite.  
Journal of Applied Physics **70**, 1614-1623 (1991).

**91LI289**

LISS K.D., MAGERL A., SCHNEIDER J.R., ZULEHNER W.  
In situ neutron diffraction study of lattice deformation during oxygen precipitation in silicon.  
Journal of Applied Physics **70**, 1276-1280 (1991).

**91PE290**

PETKOV P., ANDREJTSCHIEFF W., COPNELL J., ROBINSON S.J.  
E1 and M1 transitions strengths from two-quasiparticle structures in  $^{168}\text{Er}$ .  
Nuclear Physics **A533**, 49-70 (1991).

**91ST291**

STEINBINDER D., WIPF H., DIANOUX A.J., MAGERL A., NEUMAIER K., RICHTER D., HEMPELMANN R.  
Quantum diffusion of trapped-hydrogen interstitials in Nb : the role of the tunnel splitting.  
Europhysics Letters **16**, 211-216 (1991).

**91GA292**

GASKELL P.H., SAEED A., CHIEUX P., MCKENZIE D.R.  
Neutron-scattering studies of the structure of highly tetrahedral amorphous diamondlike carbon.  
Physical Review Letters **67**, 1286-1289 (1991).

**91HO293**

HOLDSWORTH P.C., GINGRAS M.J.P., BERGERSEN B., CHAN E.P.  
Random bonds and random fields in two-dimensional orientational glasses.  
Journal of Physics : Condensed Matter **3**, 6679-6694 (1991).

**91BE294**

BESNARD M., FOUASSIER M., LASSEGUES J.C., DIANOUX A.J., PETRY W.  
Incoherent neutron scattering study of the pseudorotational and diffusive motions of cyclopentane in condensed state.  
Molecular Physics **73**, 1059-1076 (1991).

**91AL295**

ALBRECHT T., JAEGER R., PETRY W., STEINER R., STROBL G., STUEHN B.  
Molecular dynamics in perfluoro-*n*-eicosane. III. Oscillatory and diffusive translational motion.  
Journal of Chemical Physics **95**, 2817-2822 (1991).

**91PR296**

PRAGER M., ASMUSSEN B., PRESS W., BLANK H., CARLILE C.J.  
Rotational spectra and the phase diagram of  $\text{CH}_4/\text{Ar}$  mixtures.  
Journal of Chemical Physics **95**, 569-575 (1991).

**91MA297**

MAYER H.M., STEINER M., STUESSER N., WEINFURTER H., KAKURAI K., DORNER B., LINDGARD P.A., CLAUSEN K.N., HOCK S., RODEWALD W.  
Inelastic neutron scattering measurements on  $\text{Nd}_2\text{Fe}_{14}\text{B}$  single crystals.  
Journal of Magnetism and Magnetic Materials **97**, 210-218 (1991).

**91CO298**

COLMENERO J., ALEGRIA A., ALBERDI J.M., FRICK B.  
Dynamics of the  $\alpha$ -process of polymer systems on a microscopical timescale. Neutron and nuclear magnetic resonance study.  
Journal of Non-Crystalline Solids **131-133**, 949-954 (1991).

**91BE299**

BERMEJO F.J., MARTINEZ J.L., MARTIN-MARERO D., MOMPEAN F.J., GARCIA-HERNANDEZ M., CHAHID A.  
Collective excitations in liquid deuterium studied by inelastic neutron scattering.  
Physics Letters **A 158**, 253-257 (1991).

**91VE300**

VERKERK P., BAFILE U., BAROCCHI F., DE GRAAF L.A., SUCK J.B., MUTKA H.  
Experimental determination of the linear term in the density expansion of the dynamic structure factor by means of neutron scattering.  
Physical Review Letters **67**, 1262-1265 (1991).

**91CA301**

CANNON R.D., JAYASOORIYA U.A., WHITE R.P.  
Inelastic neutron scattering studies of mixed-valency systems.  
In "Mixed Valency Systems: Applications in Chemistry, Physics and Biology", K. Prassides Ed. (Kluwer Academic Publ., 1991) pp. 283-298.

**91VE302**

VETTIER C., BURLET P., REGNAULT L.P., ROSSAT-MIGNOD J., HENRY J.Y., LAPERTOT G.  
Inelastic neutron scattering study of spin dynamics in  $YBa_2Cu_3O_{6+x}$ .  
In "Advances in Superconductivity III", K. Kajimura, H. Hayakawa Eds (Springer-Verlag, 1991) pp. 225-230.

**91BO303**

BONGIOVANNI R., OTTEWILL R.H., RENNIE A.R.  
Small-angle neutron scattering from dispersions of organophilic clays.  
Progress in Colloid and Polymer Science **84**, 299-304 (1991).

**91MU304**

MUENCH C., HOFFMANN H., IBEL K., KALUS J., NEUBAUER G., SCHMELZER U., SELBACH J.  
A shear-induced structure transition on a micellar solution measured by time-dependent small-angle neutron scattering.  
Progress in Colloid and Polymer Science **84**, 69-71 (1991).

**91CH305**

CHEONG S.W., AEPPLI G., MASON T.E., MOOK H., HAYDEN S.M., CANFIELD P.C., FISK Z., CLAUSEN K.N., MARTINEZ J.L.  
Incommensurate magnetic fluctuations in  $La_{2-x}Sr_xCuO_4$ .  
Physical Review Letters **67**, 1791-1794 (1991).

**91GO306**

GOLDBECK A., LECHNER M.D., WITZ J., NORDMEIER E., IBEL K.  
The thermal stability of turnip yellow mosaic virus under hydrostatic pressure.  
European Biophysics Journal **20**, 151-156 (1991).

**91BA307**

BASHALL A., GADE L.H., LEWIS J., JOHNSON B.F.G., MCINTYRE G.J., MCPARTLIN M.  
Direct location of the hydrido ligands in the dianion  $[H_4Os_{10}(CO)_{24}]^{2-}$  by a neutron diffraction study of its  $[(Ph_3P)_2N]^+$  salt at 20 K.  
Angewandte Chemie International Edition English **30**, 1164-1167 (1991).

**91GH308**

GHOSH R., RENNIE A.  
Workshop on Analysis of SANS and NR Data.  
Neutron News **2**, n° 3, 4-5 (1991).

**91FO309**

FORD G.W., O'CONNELL R.F.  
Radiation reaction in electrodynamics and the elimination of runaway solutions.  
Physics Letters A **157**, 217-220 (1991).

**91OL310**

OLBRICH E., CHEN D., ZACHMANN H.G., LINDNER P.  
Chain conformations in copolyesters of PET and PHB as determined by small-angle neutron scattering.  
Macromolecules **24**, 4364-4368 (1991).

**91CY311**

CYWINSKI R., KILCOYNE S.H., COX S.F.J., SCOTT C.A., SCHAERPF O.  
A  $\mu$ SR and neutron polarisation analysis study of Mn moment delocalisation in Fe substituted  $YMn_2$ .  
Hyperfine Interactions **64**, 427-434 (1990).

**91DU312**

DUBBERS D., MAMPE W.  
Der Zerfall des freien Neutrons.  
Physikalische Blätter **47**, 589-594 (1991).

**91ED313**

EDER K., GRUBER M., ZEILINGER A., GAEHLER R., MAMPE W.  
Diffraction of very cold neutrons at phase gratings.  
Physica B **172**, 329-338 (1991).

**91LA314**

LAYET J.M., BIENFAIT M., RIEUTORD F.  
Etude de la dynamique d'une monocouche d'argon sur  $MgO(100)$  par diffusion inélastique de neutrons.  
Comptes Rendus de l'Académie des Sciences de Paris, Série II, **313**, 319-322 (1991).

**91BO315**

BOISSIEU M. DE, PAPOULAR R.J., JANOT C.  
Maximum-entropy method as applied in quasi-crystallography.  
Europhysics Letters **16**, 343-347 (1991).

**91GA316**

GARCIA-MUNOZ J.L., RODRIGUEZ-CARVAJAL J., OBRADORS X., VALLET-REGI M., GONZALEZ-CALBET J., PARRAS M.  
Complex magnetic structures of the rare-earth cuprates  $R_2Cu_2O_5$  (R = Y, Ho, Er, Yb, Tm).  
Physical Review B **44**, 4716-4719 (1991).

**91CH317**

CHATTOPADHYAY T., BRUECKEL T., BURLET P.  
Spin correlation in the frustrated antiferromagnet  $MnS_2$  above the Néel temperature.  
Physical Review B **44**, 7394-7402 (1991).

**91BR318**

BROWN P.J., DEPORTES J., ZIEBECK K.R.A.  
High temperature magnetisation distribution in nickel.  
*Journal de Physique I* **1**, 1529-1537 (1991).

**91SC319**

SCHURTENBERGER P., MAGID L.J., KING S.M.,  
LINDNER P.  
Cylindrical structure and flexibility of polymerlike lecithin  
reverse micelles.  
*The Journal of Physical Chemistry* **95**, 4173-4176 (1991).

**91LA320**

LAVAGNA M.  
Charge and spin fluctuations in the Hubbard model : Fermi  
liquid properties at low temperatures.  
*International Journal of Modern Physics B* **5**,  
885-905 (1991).

**91CH321**

CHATTOPADHYAY T., BURLET P., BROWN P.J.  
Magnetic structure of  $MnS_2$  : single- $k$  or multiple- $k$ ,  
collinear or helical spin density wave ?  
*Journal of Physics : Condensed Matter* **3**, 5555-5561 (1991).

**91VU322**

VUILLARD L., CLEZARDIN P., MILLER A.  
Models of human platelet thrombospondin in solution.  
A dynamic light-scattering study.  
*Biochemical Journal* **275**, 263-266 (1991).

**91GU323**

GUILLAUME F., SOURISSEAU C., DIANOUX A.J.  
Rotational and translational motions of  $n$ -nonadecane in the  
urea inclusion compound as evidenced by incoherent  
quasielastic neutron scattering.  
*Journal de Chimie Physique* **88**, 1721-1739 (1991).

**91BO324**

BOUDARD M., BOISSIEU M. DE, JANOT C., DUBOIS  
J.M., DONG C.  
The structure of the icosahedral AlPdMn quasicrystal.  
*Philosophical Magazine Letters* **64**, 197-206 (1991).

**91VI325**

VISSER D., DORNER B., STEINER M.  
Magnetic excitations of the singlet ground state  
antiferromagnet  $CsFeBr_3$  in a magnetic field.  
*Physica B* **174**, 25-29 (1991).

**91EC326**

ECCLESTON R.S., GRIFFITHS A.R., VRTIS M.L.,  
MCINTYRE G.J., FORT D., PALMER S.B.  
The magnetic phase diagram of the Gd-Lu alloy system.  
*Physica B* **174**, 33-38 (1991).

**91RE327**

REID B.L., MCMORROW D.F., MITCHELL P.W.,  
PRAKASH O., MURANI A.P.  
Crystal field for  $Ho^{3+}$  in holmium gallium garnet.  
*Physica B* **174**, 51-55 (1991).

**91NU328**

NUNEZ V., BROWN P.J., FORSYTH J.B., TASSET F.  
Zero-field neutron polarimetry.  
*Physica B* **174**, 60-65 (1991).

**91IV329**

IVANOV A.S., RUMIANTSEV A.Y., MITROFANOV  
N.L., ALBA M.  
Low-frequency lattice dynamics of  $\gamma$ -tin.  
*Physica B* **174**, 79-82 (1991).

**91PE330**

PEARCE A., BARUCHEL J., PALMER S.B.  
An investigation of the transition from the helimagnetic  
to the conical phase in holmium.  
*Physica B* **174**, 121-125 (1991).

**91BH331**

BHATTARAI P., ZEIDLER M.D., CHIEUX P.  
Structure factor of liquid  $CCl_4$  under high pressure.  
*Physica B* **174**, 140-146 (1991).

**91KA332**

KALUS J., LINDNER P., HOFFMANN H., IBEL K.,  
MUENCH C., SANDER J., SCHMELZER U., SELBACH J.  
Transient small-angle neutron scattering of aligned micelles.  
*Physica B* **174**, 164-169 (1991).

**91RI333**

RICHTER D., FARAGO B., EWEN B., FETTERS L.J.,  
HUANG J.S.  
On the dynamics of dense polymer systems.  
*Physica B* **174**, 209-217 (1991).

**91BL334**

BLANK H., KEARLEY G.J.  
Coupling of  $NH_3$  quantum rotors.  
*Physica B* **174**, 233-236 (1991).

**91TO335**

TOMKINSON J., KEARLEY G.J., FILLAUX F.  
The vibrational spectroscopy of hydrogen bonds.  
*Physica B* **174**, 246-250 (1991).

**91KN336**

KNOP W., HIRAI M., OLAH G., MEERWINCK W.,  
SCHINK H.J., STUHRMANN H.B., WAGNER R.,

WENKOW-ESSOUNI M., ZHAO J., SCHAERPF O., CRICHTON R.R., KRUMPOLC M., NIERHAUS K.H., NIINIKOSKI T.O., RIJLLART A.

Polarised neutron scattering from dynamic polarised targets in biology.

Physica B **174**, 275-290 (1991).

**91TA337**

TASSET F.

Recent progress in polarised neutron diffraction at ILL and the emergence of a  $^3\text{He}$  neutron polarisation filter.

Physica B **174**, 506-513 (1991).

**91SC338**

SCHAERPF O.

Thin-film devices and their role in future neutron spectroscopic investigations.

Physica B **174**, 514-527 (1991).

**91EF339**

EFFENBERGER H., FUESS H., MUELLER G., VOGT T.

Crystal structure and hydrogen bonding in Li/H-exchanged petalite,  $\text{HAlSi}_4\text{O}_{10}$ .

Zeitschrift für Kristallographie **197**, 27-40 (1991).

**91CO340**

COOK J.C., RICHTER D., HEMPELMANN R., ROSS D.K., ZUECHNER H.

Quasi-elastic neutron scattering studies of collective and correlated tracer diffusion in the systems  $\alpha'$ - $\text{NbD}_x$  and  $\alpha'$ - $\text{NbH}_x$ .

Journal of the Less-Common Metals **172-174**, 585-594 (1991).

**91CO341**

COLMENERO J., ALEGRIA A., ALBERDI J.M., ALVAREZ F., FRICK B.

Dynamics of the  $\alpha$  relaxation of a glass-forming polymeric system : Dielectric, mechanical, nuclear-magnetic-resonance, and neutron-scattering studies.

Physical Review **B 44**, 7321-7329 (1991).

**91AM342**

AMOROS P., IBANEZ R., BELTRAN A., BELTRAN D., FUERTES A., GOMEZ-ROMERO P., HERNANDEZ E., RODRIGUEZ-CARVAJAL J.

Oxovanadium (IV) hydrogen phosphate hydrates : A time-resolved neutron powder diffraction study.

Chemistry of Materials **3**, 407-413 (1991).

**91PA343**

PALACIO F., ANDRES M., RODRIGUEZ-CARVAJAL J., PANNETIER J.

Magnetic structures of the Mn III weak ferromagnets

$\text{AMnF}_4 \cdot \text{H}_2\text{O}$  ( $A = \text{Rb}$  and  $\text{K}$ ).

Journal of Physics : Condensed Matter **3**, 2379-2390 (1991).

**91CL344**

CLAMP M.E., FENN R.H., MILLS O.S., MITCHELL P.W., BRAMWELL S.

Structure of superconducting tetragonal  $\text{HoBa}_2\text{Cu}_3\text{O}_{7-\delta}$

Physica B **174**, 364-366 (1991).

**91MU345**

MUENCH C., HOFFMANN H., KALUS J., IBEL K., NEUBAUER G., SCHMELZER U.

Decay of a shear-induced phase transition on a micellar solution measured by time-dependent small-angle neutron scattering.

Journal of Applied Crystallography **24**, 740-746 (1991).

**91BR346**

BRAUTMEIER D., STAMM M., LINDNER P.

Study on interdiffusion of polystyrenes of high molecular weight by SANS.

Journal of Applied Crystallography **24**, 665-671 (1991).

**91MU347**

MUELLER-STACH M., FRANZ H., HERR U., PEISL J., PETRY W., WALLNER G.

Microstructure of nanocrystalline  $\text{TiO}_2$  and Ni at different degrees of compactness.

Journal of Applied Crystallography **24**, 603-606 (1991).

**91KN348**

KNOP W., MEERWINCK W., OLAH G., SCHINK H.J., STUHRMANN H.B., WAGNER R., WENKOW-ESSOUNI M., ZHAO J., SCHAERPF O., NIERHAUS K.H., NIINIKOSKI T.O., RIJLLART A.

Nuclear spin order and excitation of inner-shell electrons in macromolecular structure research. An application to the large subunit of the *E. coli* ribosome.

Journal of Applied Crystallography **24**, 493-500 (1991).

**91GA349**

GAVARRI J.R., CAREL C., MONNEREAU O., VACQUIER G., VETTIER C., HEWAT A.W.

Evolutions structurales et effets de pression dans des céramiques supraconductrices à haute  $T_c$ .

Journal de Physique III **1**, 1781-1785 (1991).

**91RI350**

RICHARDSON D.J., PENDLEBURY J.M., IAYDJIEV P., MAMPE W., GREEN K., KILVINGTON A.I.

Measurement of the energy dependence of the neutron loss per bounce function on reflection from oil and grease surfaces using monochromatic ultracold neutrons.

Nuclear Instruments and Methods in Physics Research **A 308**, 568-573 (1991).

**91BR351**

BRAVIC G., CHASSEAU D., GAULTIER J.,  
ROSSEINSKY M.J., KURMOO M., DAY P., FILHOL A.  
Structural properties of two modifications of hydrated  
BEDT-TTF chloride salts.  
*Synthetic Metals* **41-43**, 2035-2038 (1991).

**91SU352**

SUCK J.B.  
Brillouin scattering with neutrons and recent results from the  
investigation of compressed gases.  
*Journal of Physics : Condensed Matter* **3**, F73-F86 (1991).

**91MA353**

MATHAN N. DE, HUSSON E., CALVARIN G.,  
GAVARRI J.R., HEWAT A.W., MORELL A.  
A structural model for the relaxor  $\text{PbMg}_{1/3}\text{Nb}_{2/3}\text{O}_3$  at 5 K.  
*Journal of Physics : Condensed Matter* **3**, 8159-8171 (1991).

**91FU354**

FUERTES A., OBRADORS X., NAVARRO J.M.,  
GOMEZ-ROMERO P., CASAN-PASTOR N., PEREZ F.,  
FONTCUBERTA J., MIRAVITLLES C., RODRIGUEZ-  
CARVAJAL J., MARTINEZ B.  
Cation stoichiometric  $\text{La}_2\text{CaCu}_2\text{O}_{6+y}$  : an undoped oxide  
superconducting at 45 K.  
*Ceramic Transactions* **18**, 129-136 (1991).

**91SO355**

SOURISSEAU C., CRUEGE F., FOUASSIER M., ALBA M.  
Second-order Raman effects, inelastic neutron scattering and  
lattice dynamics in  $2\text{H-WS}_2$ .  
*Chemical Physics* **150**, 281-293 (1991).

**91TH356**

THALMEIER P., LUETHI B.  
The electron-phonon interaction in intermetallic compounds.  
In "Handbook on the Physics and Chemistry of Rare Earths  
Vol. 14", K.A. Gschneider Jr., L. Eyring Eds. (Elsevier,  
1991) pp. 225-341.

**91WI357**

WILLIAMS J.H., KEARLEY G.J., AXON S.A.,  
KLINOWSKI J.  
Probing the dynamics of methylated benzenes adsorbed on  
zeolite ZSM-5 by quasielastic neutron scattering.  
*Journal of the Chemical Society. Chemical Communications*  
959-961 (1991).

**91EB358**

EBEL C., KRISHNAN G., ALTEKAR W., ZACCAI G.  
Small-angle neutron scattering study of halophilic  
glyceraldehyde 3-phosphate dehydrogenase (hGAPDH).  
*Physica B* **174**, 306-308 (1991).

**91BE359**

BEE M., DIANOUX A.J., JANIK J.A., JANIK J.M.,  
PODSIADLY R.  
A quasielastic neutron scattering study of the self-diffusion  
coefficients for the homologous series  
4,4'-di-*n*-alkyloxyazoxybenzenes.  
*Liquid Crystals* **10**, 199-206 (1991).

**91HI360**

HILFRICH K., EBEL T., PETRY W., SCHAERPF O.,  
NEMBACH E.  
Order in iron - 30 at.% aluminium investigated by neutron  
scattering.  
*Scripta Metallurgica et Materialia* **25**, 1857-1862 (1991).

**91DU361**

DUBBERS D.  
Particle physics with cold neutrons.  
*Progress in Particle and Nuclear Physics* **26**, 173-252 (1991).

**91CA362**

CALDES M.T., NAVARRO J.M., PEREZ F., CARRERA  
M., FONTCUBERTA J., CASAN-PASTOR N.,  
MIRAVITLLES C., OBRADORS X., RODRIGUEZ-  
CARVAJAL J., GONZALEZ-CALBET J.M., VALLET-  
REGI M., GARCIA A., FUERTES A.  
Electron microscopy, neutron diffraction, and physical  
properties of  $\text{Bi}_4\text{Sr}_g\text{Cu}_5\text{O}_{19+y}$ .  
*Chemistry of Materials* **3**, 844-852 (1991).

**91BA363**

BAUSENWEIN T., BERTAGNOLLI H., TOEDHEIDE K.,  
CHIEUX P.  
Multiple scattering and self-absorption correction for high-  
pressure neutron diffraction with cylindrical cells.  
*Nuclear Instruments and Methods in Physics Research B* **61**,  
527-534 (1991).

**91ST364**

STUHR U., WIPF H., FRICK B.  
Hydrogen diffusion in f.c.c.  $\text{TiH}_x$ .  
*Journal of the Less-Common Metals* **172-174**, 678-684  
(1991).

**91DA365**

DAUDIN B., LEGRAND J.F., MACCHI F.  
Microscopic and macroscopic effects of electron irradiation  
on ferroelectric poly(vinylidene fluoride-TrFe) copolymers.  
*Journal of Applied Physics* **70**, 4037-4044 (1991).

**91BE366**

BERK N.F., RUSH J.J., UDOVIC T.J., ANDERSON I.S.  
Anomalous hydrogen dynamics in rare earth metals.  
*Journal of the Less-Common Metals* **172-174**, 496-508  
(1991).

**91ST367**

STAUB U., ALLENSPACH P., MESOT J., FURRER A.,  
MUELLER R., SCHWEIZER T., GAUCKLER L.J.,  
BLANK H., MUTKA H.

Neutron scattering studies of  $\text{Bi}_2\text{Sr}_2\text{Ca}_{0.5}\text{Ho}_{0.5}\text{Cu}_2\text{O}_{8+x}$ .  
*Zeitschrift für Physik B* **85**, 35-41 (1991).

**91RI368**

RIECK C.T., SCHARNBERG K., SCHOPOHL N.

Quasiclassical theory of the upper critical field of high-field  
superconductors. Application to momentum-dependent  
scattering.

*Journal of Low Temperature Physics* **84**, 381-464 (1991).

**91KR369**

KRAEMER K., MEYER G., FISCHER P., HEWAT A.W.,  
GUEDEL H.U.

Neutron diffraction investigation of magnetic phase  
transitions to long-range antiferromagnetic ordering in the  
"free-electron" praseodymium halides  $\text{Pr}_2\text{X}_5$  ( $X = \text{Br}, \text{I}$ ).

*Journal of Solid State Chemistry* **95**, 1-13 (1991).

**91JA370**

JANOT C., BOISSIEU M. DE

Neutron scattering approaches to quasicrystals.

In "Quasicrystals: The State of the Art", D.P. DiVincenzo,  
P. Steinhardt Eds. (World Scientific, 1991) pp. 57-94.

**91HA371**

HALLBRUCKER A., MAYER E., O'MARD L.P., DORE  
J.C., CHIEUX P.

Structural characterisation of hyperquenched glassy water  
and vapour-deposited amorphous ice.

*Physics Letters A* **159**, 406-410 (1991).

**91DI372**

DING J., STEINER T., ZABEL V., HINGERTY B.E.,  
MASON S.A., SAENGER W.

Neutron diffraction study of the hydrogen bonding in  
partially deuterated  $\gamma$ -cyclodextrin• $15.7\text{D}_2\text{O}$  at  $T = 110 \text{ K}$ .

*Journal of the American Chemical Society* **113**, 8081-8089  
(1991).

**91HE373**

HEIMING A., PETRY W., VOGL G., TRAMPENAU J.,  
SCHOBER H.R., CHEVRIER J., SCHAERPF O.

The local displacement field around Co and Nb solutes in  
 $\omega$ -phase forming bcc-Zr at high temperatures.

*Zeitschrift für Physik B* **85**, 239-248 (1991).

**91CH374**

CHATTOPADHYAY T., BROWN P.J., STEPANOV A.A.,  
WYDER P., VOIRON J., ZVYAGIN A.I., BARILO S.N.,  
ZHIGUNOV D.I., ZOBKALO I.

Magnetic phase transitions in  $\text{Gd}_2\text{CuO}_4$ .

*Physical Review B* **44**, 9486-9491 (1991).

**91NO375**

NOZIERES P.

Solid surfaces: capillarity vs elasticity.

*Lecture Notes in Physics* **386**, 113-127. (1991).

**91LA376**

LAUTER H.J., GODFRIN H., FRANK V.L.P., LEIDERER P.  
 $^4\text{He}$  films on graphite studied by neutron scattering.

In "Excitations in Two-Dimensional and Three-Dimensional  
Quantum Fluids", A.G.F. Wyatt, H.J. Lauter Eds. (Plenum  
Press, 1991) pp. 419-427.

**91KU377**

KULDA J., BARUCHEL J., GUIGAY J.P., SCHLENKER M.

Extinction effects in polarized neutron diffraction from  
magnetic crystals. I. Highly perfect MnP and YIG samples.

*Acta Crystallographica A* **47**, 770-775 (1991).

**91WA378**

WAGNER W., WEIDENMANN A., PETRY W., GEIBEL  
A., GLEITER H.

Magnetic microstructure of nanostructured Fe, studied by  
small angle neutron scattering.

*Journal of Materials Research* **6**, 2305-2311 (1991).

**91SC379**

SCHERM R., GUCKELSBERGER K., STUNAU A.,  
FAK B.

Elementary excitations in Fermi liquids: Neutron scattering  
by  $^3\text{He}$  and  $^3\text{He}$ - $^4\text{He}$  mixtures.

In "Excitations in Two-Dimensional and Three-Dimensional  
Quantum Fluids", A.G.F. Wyatt, H.J. Lauter Eds. (Plenum  
Press, 1991) pp. 231-238.

**91PE380**

PERNET M., RODRIGUEZ-CARVAJAL J., GONDRAND  
M., FONTCUBERTA J., STROBEL P., JOUBERT J.C.

Lithium insertion into  $\gamma\text{-Fe}_2\text{O}_3$ .

In "Advances in Ferrites Vol. 1", C.M. Srivastava, M.J.  
Patni Eds. (Oxford & IBH Publ. Co., 1989) pp. 61-65.

**91DE381**

DE KRUIF C.G., MAY R.P.

$\kappa$ -casein micelles: structure, interaction and gelling studied  
by small-angle neutron scattering.

*European Journal of Biochemistry* **200**, 431-436 (1991).

**91HE382**

HEWAT A.W., HEWAT E.A., BORDET P., CAPPONI J.J.,  
CHAILLOUT C., CHENEVAS J., HODEAU J.L.,  
MAREZIO M.

Relations between structure and  $T_c$  in 123, 124 and thallium  
oxide superconductors.

*Materials Research Society Symposium Proceedings Vol.*  
**156**, 283-294 (1989).

**91RI383**

RICHTER D., ZORN R., FRICK B., FARAGO B.  
Neutron scattering experiments in the neighborhood of the glass transition in polybutadiene - a test of mode coupling. *Berichte der Bunsengesellschaft für Physikalische Chemie* **95**, 1111-1118 (1991).

**91CZ384**

CZIZEK M., VOGT T., FUESS H.  
Aniline in Yb, Na-Y: A neutron powder diffraction study. *Zeolites* **11**, 832-836 (1991).

**91BO385**

BOERNER H.G., CASTEN R.F., FOERSTER I., LIEBERZ D., BRENTANO P.VON, ROBINSON S.J., EGIDY T. VON, HLAWATSCH G., LINDNER H., GELTENBORT P., HOYLER F., FAUST H., COLVIN G., KANE W.R., MCPHAIL M.  
Level structure of  $^{191}\text{Os}$ : Coexisting oblate and prolate configurations. *Nuclear Physics A* **534**, 255-293 (1991).

**91NU386**

NUNEZ P., TRESSAUD A., HAHN F., MASSA W., BABEL D., BOIREAU A., SOUBEYROUX J.L.  
A new 1D-antiferromagnet : crystal and magnetic structures of  $\text{TlMnF}_4 \cdot \text{H}_2\text{O}$ . *Physica Status Solidi (a)* **127**, 505-517 (1991).

**91BI387**

BITTER T., EISERT F., EL-MUZEINI P., KESSLER M., KINKEL U., KLEMT E., LIPPERT W., MEIENBURG W., WERNER R., GOBRECHT K., DUBBERS D.  
A large volume magnetic shielding system for the ILL neutron-antineutron oscillation experiment. *Nuclear Instruments and Methods in Physics Research A* **309**, 521-529 (1991).

**91BA388**

BALLOU R., LACROIX C., NUNEZ REGUEIRO M.D.  
Frustration-induced vanishing of magnetic moments in  $\text{RMn}_2$  systems. *Physical Review Letters* **66**, 1910-1913 (1991).

**91ME389**

MENDES E., LINDNER P., BUZIER M., BOUE F., BASTIDE J.  
Experimental evidence for inhomogeneous swelling and deformation in statistical gels. *Physical Review Letters* **66**, 1595-1598 (1991).

**91EI390**

EISENSTEIN M., SHARON R., BERKOVITCH-YELLIN Z., GEWITZ H.S., WEINSTEIN S., PEBAY-PEYROULA E., ROTH M., YONATH A.  
The interplay between x-ray crystallography, neutron diffraction, image reconstruction, organo-metallic chemistry

and biochemistry in structural studies of ribosomes. *Biochimie* **73**, 879-886 (1991).

**91BA391**

BASSEREAU P., MARIGNAN J., PORTE G., MAY R.  
Experimental measure of the anisotropy of the Bragg singularity in lyotropic smectics. *Europhysics Letters* **15**, 753-758 (1991).

**91SH392**

SHENDER E.F., RAMMAL R.  
Magnetic two-level systems and anomalies in the magnetic behaviour of high- $T_c$  parent compounds. *Europhysics Letters* **15**, 795-800 (1991).

**91MC393**

MCMORROW D.F., PATTERSON C., GODFRIN H., JEHAN D.A.  
Spin waves in the one-spin-slip phase of holmium. *Europhysics Letters* **15**, 541-546 (1991).

**91AL394**

ALBRECHT T., ELBEN H., JAEGER R., KIMMIG M., STEINER R., STROBL G., STUEHN B., SCHWICKERT H., RITTER C.  
Molecular dynamics in perfluoro-*n*-eicosane. II. Components of disorder. *Journal of Chemical Physics* **95**, 2807-2816 (1991).

**91LA395**

LACORRE P., PANNETIER J., FLEISCHER T., HOPPE R., FERREY G.  
Ordered magnetic frustration : XVI. Magnetic structure of  $\text{CsCoF}_4$  at 1.5 K. *Journal of Solid State Chemistry* **93**, 37-45 (1991).

**91WI396**

WILLIAMS J.H.  
An inelastic neutron scattering study of the dynamics of the van der Waals complex  $\text{C}_6\text{H}_6 : \text{C}_6\text{F}_6$ . *Molecular Physics* **73**, 99-112 (1991).

**91WI397**

WILLIAMS J.H.  
A quasielastic neutron scattering investigation of the van der Waals complex of benzene and hexafluorobenzene. *Molecular Physics* **73**, 113-125 (1991).

**91SI398**

SIMON J.P., LYON O., BRUSON A., RIEUTORD F.  
Anomalous small-angle X-ray diffraction of an Nd-Fe multilayer. *Journal of Applied Crystallography* **24**, 156-163 (1991).

**91JA399**

JANSSEN T.  
Commensurate approximants of icosahedral quasi-crystals.  
*Europhysics Letters* **14**, 131-136 (1991).

**91JA400**

JANSSEN T.  
The symmetry of quasiperiodic systems.  
*Acta Crystallographica A* **47**, 243-255 (1991).

**91VI401**

VISSER D., CARLING S.G., DAY P., DEPORTES J.  
Magnetic structure of  $\text{KMnPO}_4 \cdot \text{H}_2\text{O}$ .  
*Journal of Applied Physics* **69**, 6016-6018 (1991).

**91DU402**

DUITS M.H.G., MAY R.P., VRIJ A., DE KRUIF C.G.  
Partial structure factors in colloidal silica mixtures determined with small-angle neutron scattering contrast variation.  
*Journal of Chemical Physics* **94**, 4521-4531 (1991).

**91LA403**

LACORRE P., LEBLANC M., PANNETIER J., FERREY G.  
Ordered magnetic frustration. XV Re-examination of the magnetic structure of  $\alpha\text{-KCrF}_4$ .  
*Journal of Magnetism and Magnetic Materials* **94**, 337-341 (1991).

**91GI404**

GIGNOUX D., MURANI A.P., SCHMITT D., ZERGUINE M.  
Paramagnetic spectral response of the Kondo lattice tetragonal compound  $\text{CePt}_2\text{Si}_2$ .  
*Journal de Physique I* **1**, 281-287 (1991).

**91RI405**

RITTER C., KILCOYNE S.H., CYWINSKI R.  
The magnetic structure of  $\text{DyMn}_2$ .  
*Journal of Physics : Condensed Matter* **3**, 727-738 (1991).

**91TE406**

TERECH P.  
Optical birefringence and dichroism in physical steroid organogels.  
*Liquid Crystals* **9**, 59-70 (1991).

**91HA407**

HAYDEN S.M., AEPPLI G., CHEONG S.W., MOOK H.A., FISK Z., RYTZ D.  
Neutron scattering studies on lanthanum cuprates.  
*Journal of Applied Physics* **69**, 4519 (1991).

**91VI408**

VISSER D., MCINTYRE G.J., HARRISON A.  
Magnetic ordering in triangular antiferromagnets : A neutron scattering study.  
*Journal of Applied Physics* **69**, 5968 (1991).

**91VI409**

VISSER D., BRAMWELL S.T., KREMER R.K.  
Magnetic and structural characterization of the 2D XY-ferromagnet  $\text{Rb}_2\text{CrCl}_2\text{I}_2$ .  
*Journal of Applied Physics* **69**, 6024 (1991).

**91VI410**

VISSER D., DORNER B., HARRISON A.  
Temperature dependence of the magnetic excitations in the modified triangular induced moment antiferromagnet  $\text{RbFeBr}_3$  at the soft mode point.  
*Journal of Applied Physics* **69**, 6232 (1991).

**91BO411**

BOUCHER B., CHIEUX P.  
Nuclear and magnetic medium-range order in rare-earth-based amorphous alloys.  
*Journal of Physics : Condensed Matter* **3**, 2207-2229 (1991).

**91SC412**

SCHRAEDER T., LOIDL A., VOGT T.  
Antiferroelectric phase transitions in  $(\text{NaCN})_{1-x}(\text{KCN})_x$ .  
*Ferroelectrics* **106**, 181-186 (1990).

**91MI413**

MICHAELSEN S., LIEB K.P., ROBINSON S.J.  
Complete spectroscopy of  $^{51,52}\text{V}$  via the  $^{50,51}\text{V}(n,\gamma)$  reactions.  
*Zeitschrift für Physik A* **338**, 371-387 (1991).

**91FO414**

FORD G.W., O'CONNELL R.F.  
Structure effects on the radiation emitted from an electron.  
*Physical Review A* **44**, 6386-6387 (1991).

**91DO415**

DONG C., DUBOIS J.M.  
Quasicrystals and crystalline phases in  $\text{Al}_{65}\text{Cu}_{20}\text{Fe}_{10}\text{Cr}_5$  alloy.  
*Journal of Materials Science* **26**, 1647-1654 (1991).

**91JA416**

JANSSEN D., SCHUCK P.  
On some aspects of selfconsistent RPA theory.  
*Zeitschrift für Physik A* **339**, 43-50 (1991).

**91DO417**

DONNELLY K., FAWLER J.F., COEY J.M.D., FRUCHART D., MIRAGLIA S., SOUBEYROUX J.L.  
The effect of hydrogen on  $\text{Bi}_{1.8}\text{Pb}_{0.2}\text{Sr}_{2.2}\text{Ca}_{1.9}\text{Cu}_3\text{O}_x$  : A neutron diffraction study.  
*Physica C* **172**, 207-212 (1991).

**91BE418**

BENOIT A., PUJOL S.  
A dilution refrigerator insensitive to gravity.  
*Physica B* **169**, 457-458 (1991).

**91KV419**

KVARDAKOV V.V., SANDONIS J., PODURETS K.M., SHILSTEIN S.S., BARUCHEL J.

Study of the Morin transition in nearly perfect crystals of hematite by diffraction and topography.

Physica B **168**, 242-250 (1991).

**91MA420**

MALETTA H., CHATTOPADHYAY T., BROWN P.J.

Reply to the comment by Clinton and Lynn.

Physica C **174**, 489-490 (1991).

**91CO421**

CONNELL J.G., RICHARDS R.W., RENNIE A.R.

Phase-separation kinetics in concentrated solutions of linear diblock copolymers of polystyrene and polyisoprene from time-resolved small-angle neutron scattering.

Polymer **32**, 2033-2042 (1991).

**91KU422**

KULLMANN W., EICHHORN G., RAUH H., GEICK R., ECKOLD G., STEIGENBERGER U.

Lattice dynamics and phonon dispersion in the narrow gap semiconductor  $\text{Bi}_2\text{Te}_3$  with sandwich structure.

Physica Status Solidi b **162**, 125-140 (1990).

**91SA423**

SARKISSIAN B.V.B., RAINFORD B.D.

Neutron spin echo studies in Pd-Mn alloys.

Solid State Communications **78**, 185-189 (1991).

**91AL424**

ALA-NISSILA T., KJOLL J., YING S.C., TAHIR-KHELI R.A.

Model for diffusion on deformable lattices. II. Tracer diffusion.

Physical Review B **44**, 2133-2141 (1991).

**91AL425**

ALA-NISSILA T., KJOLL J., YING S.C., TAHIR-KHELI R.A.

Model for diffusion on deformable lattices. I. Collective diffusion.

Physical Review B **44**, 2122-2132 (1991).

**91AN426**

ANDERSON I.S., BERK N.F., RUSH J.J., UDOVIC T.J., BARNES R.G., MAGERL A., RICHTER D.

Anderson et al. Reply.

Physical Review Letters **66**, 2415 (1991).

**91FA427**

FARAGO B., RICHTER D., HUANG J.S., SAFRAN S.A., MILNER S.T.

Shape and size fluctuations of microemulsions droplets: The role of cosurfactant.

Physical Review Letters **65**, 3348-3351 (1990).

**91SI428**

SIEKER L., COHEN-ADDAD C., NEUBURGER M., DOUCE R.

Crystallographic data for H-protein from the glycine decarboxylase complex.

Journal of Molecular Biology **220**, 223-224 (1991).

**91LE429**

LEDERER H., MORTENSEN K., MAY R.P., BAER G., CRESPI H.L., DERSCH D., HEUMANN H.

Spatial arrangement of  $\sigma$ -factor and core enzyme of *Escherichia coli* RNA polymerase. A neutron solution scattering study.

Journal of Molecular Biology **219**, 747-755 (1991).

**91GA430**

GAVARRI J.R., MONNEREAU O., VACQUIER G., CAREL C., VETTIER C.

Anisotropic compressibility of the orthorhombic phase  $\text{Bi}_2\text{Sr}_2\text{Ca}_1\text{Cu}_2\text{O}_8$ .

Physica C **172**, 213-216 (1990).

**91BA431**

BAFFIER N., ALDEBERT P., LIVAGE J., HAESSLIN H.W.

Small angle neutron scattering study of vanadium pentoxide gels swelling.

Journal of Colloid and Interface Science **141**, 467-474 (1991).

**91AL432**

ALLENSPACH P., MESOT J., STAUB U., FURRER A., BLANK H., MUTKA H., VETTIER C., KALDIS E., KARPINSKI J., RUSIECKI S.

The crystalline electric field as a direct probe for charge transfer processes in high temperature superconductors.

Superconductor Science and Technology **4**, S76-S78 (1991).

**91BU433**

BUNE A.V., FRIDKIN V.M., VEXKHOVSKAYA K.A., LEGRAND J.F.

Photoelectric properties of the optically sensitized ferroelectric copolymers VDF-TrFE.

Ferroelectrics Letters Section **12**, 103-107 (1991).

**91FO434**

FORD G.W., O'CONNELL R.F.,

Total power radiated by an accelerated charge.

Physics Letters A **158**, 31-32 (1991).

**91DE435**

DEGIORGIO V., BANFI G., RIGHINI G., RENNIE A.

Small-angle neutron scattering study of semiconductor microcrystallites in optical glasses.

Applied Physics Letters **57**, 2879-2881 (1990).

**91MA436**

MARMEGGI J.C., LANDER G.H., BRUECKEL T., ZEYEN C.M.E.

New developments in modulated phases of  $\alpha$ -U.  
Phase Transitions **31**, 145-155 (1991).

**91BO437**

BOURSON P., DURAND D., BOUILLOT J., SOUBEYROUX J.L.

Importance of annealing on the order-disorder phase transition in alkali cyanides.  
Phase Transitions **31**, 277-281 (1991).

**91BE438**

BEZOU C., CHRISTENSEN A.N., COX D., LEHMANN M.S., NONAT A.

Crystalline structures of  $\text{CaSO}_4 \cdot 0.5\text{H}_2\text{O}$  and  $\text{CaSO}_4 \cdot 0.6\text{H}_2\text{O}$   
Comptes Rendus de l'Académie des Sciences Série II **312**, 43-48 (1991).

**91RO439**

ROUSSELOT C., TACHEZ M., MALUGANI J.P., MERCIER R., CHIEUX P.

Characterization of intermediate-range order in superionic  $\text{AgPO}_3\text{-AgX}$  ( $X = \text{I, Br, Cl}$ ) glasses by neutron diffraction.  
Solid State Ionics **44**, 151-158 (1991).

**91MI440**

MIRAGLIA S., SOUBEYROUX J.L., KOLBECK C., ISNARD O., FRUCHART D., GUILLOT M.

Structural and magnetic properties of ternary nitrides  $\text{R}_2\text{Fe}_{17}\text{N}_x$  ( $R = \text{Nd, Sm}$ ).  
Journal of the Less-Common Metals **171**, 51-61 (1991).

**91DU441**

DUBBERS D.

Neutron decay, the standard model and the question of right-handed weak currents.

In "International Summer School Low Energy Weak Interaction" (LEWI'90), (Dubna, 1991) pp. 326-330

**91BA442**

BARRE S., MUTKA H., ROUCAU C., LITZLER A., SCHNECK J., TOLEDANO J.C., BOUFFARD S., RULLIER-ALBENQUE F.

Influence of defects on the incommensurate modulation in irradiated  $\text{Ba}_2\text{NaNb}_5\text{O}_{15}$ .  
Physical Review **B 43**, 11154-11161 (1991).

**91LA443**

LAMBERT S., MUYLDERMANS S., BALDWIN J., KILNER J., IBEL K., WIJNS L.

Neutron scattering studies of chromatosomes.  
Biochemical and Biophysical Research Communications **179**, 810-816 (1991).

**91BU444**

BUDTZ-JORGENSEN C., BAHNSEN A., OLESEN C., MADSEN M.M., JONASSON P., SCHNOPPER H.W., OED A.

Microstrip proportional counters for X-ray astronomy.  
Nuclear Instruments and Methods in Physics Research **A 310**, 82-87 (1991).

**91OE445**

OED A., GELTENBORT P., BUDTZ-JORGENSEN C.  
Substratum and layout parameters for microstrip anodes in gas detectors.

Nuclear Instruments and Methods in Physics Research **A 310**, 95-97 (1991).

**91WI446**

WILKINSON C., LEHMANN M.S.

Quasi-Laue neutron diffractometer.

Nuclear Instruments and Methods in Physics Research **A 310**, 411-415 (1991).

**91GA447**

GABRYS B., SCHAERPF O., PEIFFER D.G.

A new development in neutron diffraction : Spin polarisation analysis.

In "Integration of Fundamental Polymer Science and Technology-5", P.J. Lemstra, L.A. Kleintjens Eds. ( Elsevier Applied Science, 1991) pp. 271-275.

**91BO448**

BOYSEN H., FREY F., VOGT T.

Neutron powder investigation of the tetragonal to monoclinic phase transformation in undoped zirconia.  
Acta Crystallographica **B 47**, 881-886 (1991).

**91RE449**

REYNOLDS P.A., FIGGIS B.N., KUCHARSKI E.S., MASON S.A.

Neutron diffraction at 115 K to  $1.09 \text{ \AA}^{-1}$  from cobalt phthalocyanine.

Acta Crystallographica **B 47**, 899-904 (1991).

**91CO450**

COWLEY R.A., PATTERSON C., COWLAM N., IVISON P.K., MARTINEZ J., CUSSEN L.D.

Non-collinear magnetic structures of Fe-based amorphous alloys.

Journal of Physics : Condensed Matter **3**, 9521-9537 (1991).

**91IB451**

IBARRA M.R., MARQUINA C., PAVLOVIC A.S., RITTER C.

Study of the influence of the magnetoelastic energy in driving the magnetic and structural transition in TbCu.  
Journal of Applied Physics **70**, 5989-5991 (1991).

**91OB452**

OBRADORS X., MARTINEZ B., BATLLE X.,  
RODRIGUEZ-CARVAJAL J., FERNANDEZ-DIAZ M.T.,  
MARTINEZ J.L., ODIER P.  
Magnetic transitions in  $\text{Pr}_2\text{NiO}_4$  single crystal.  
Journal of Applied Physics **70**, 6329-6331 (1991).

**91AU453**

AUDIER M., BRECHET Y., BOISSIEU M. DE, GUYOT  
P., JANOT C., DUBOIS J.M.  
Perfect and modulated quasicrystals in the system Al-Fe-Cu.  
Philosophical Magazine **B 63**, 1375-1393 (1991).

**91BO454**

BOENI P., ANDERSON I.S., HAUERT R., RUTERANA  
P., SOLT K., FARNOUX B., HERDMAN G.J., PENFOLD  
J., SCHAERPF O.  
Investigation and growth of multilayers.  
In "ICANS-XI. 11. Meeting of International Collaboration  
on Advanced Neutron Sources", held October 22-26, 1990 in  
Tsukuba, Japan, KEK-REPORT-90-25 pp. 910-918 (1990).

**91UL455**

ULBIG S., LIEB K.P., BOERNER H.G., JOLIE J.,  
ROBINSON S.J., DEWEY M.S.  
Grid lifetime spectroscopy of medium mass nuclei.  
In "VI International School on Neutron Physics.  
Proceedings" held 8-18 October 1990 in Alushta, USSR,  
Vol. I pp. 179-187 (1991).

**91DO456**

DORNER B., BURKEL E.  
Measurements of phonon dispersion curves by X-rays with  
very high energy resolution.  
In "VI International School on Neutron Physics.  
Proceedings" held 8-18 October 1990 in Alushta, USSR,  
Vol. II pp. 51-57 (1991).

**91LA457**

LAUTER H.J., BLAND J.A.C., BATESON R.D.,  
JOHNSON A.D.  
Magnetic moments in ultrathin films determined by spin-  
polarised neutron reflection.  
In "VI International School on Neutron Physics.  
Proceedings" held 8-18 October 1990 in Alushta, USSR,  
Vol. II pp. 90-99 (1991).

**91CU458**

CURRAT R.  
Neutron investigation of modulated crystals.  
In "VI International School on Neutron Physics.  
Proceedings" held 8-18 October 1990 in Alushta, USSR,  
Vol. II pp. 124-127 (1991).

**91DI459**

DIANOUX A.J., BRUSETTI R., GOUGEON P., POTEL  
M., BONJOUR E., CALEMCZUK R.

Evidence for Einstein-like modes in the superconducting  
molybdenum selenides  $\text{M}_2\text{Mo}_6\text{Se}_6$ .  
In "VI International School on Neutron Physics.  
Proceedings" held 8-18 October 1990 in Alushta, USSR,  
Vol. II pp. 128-135 (1991).

**91DO460**

DORNER B., VISSER D., STEINER M.  
Magnetic excitations and phase transition of  $\text{CsFeBr}_3$  in an  
external magnetic field.  
In "VI International School on Neutron Physics.  
Proceedings" held 8-18 October 1990 in Alushta, USSR,  
Vol. II pp. 136-139 (1991).

**91KN461**

KNOP W., STUHRMANN H.B., WAGNER R.,  
WENKOW-ESSOUNI M., ZHAO J., SCHAERPF O.,  
KRUMPOLC M., NIERHAUS K., NIINIKOSKI T.O.,  
RIJLLART A.  
Polarized neutron scattering from dynamic polarized targets  
in biology.  
In "VI International School on Neutron Physics.  
Proceedings" held 8-18 October 1990 in Alushta, USSR,  
Vol. II pp. 218-239 (1991).

**91FU462**

FURRER A., ALLENSPACH P., MESOT J., STAUB U.,  
BLANK H., MUTKA H., VETTIER C., KALDIS E.,  
KARPINSKI J., RUSIECKI S., MIRMELSTEIN A.  
Neutron spectroscopy studies of the relation between  
superconductivity and the crystal field in high-temperature  
superconductors.  
In "VI International School on Neutron Physics.  
Proceedings" held 8-18 October 1990 in Alushta, USSR,  
Vol. II pp. 278-289 (1991).

**91HE463**

HEWAT A.W.  
Neutron powder diffraction and relations between structure  
and superconductivity.  
In "VI International School on Neutron Physics.  
Proceedings" held 8-18 October 1990 in Alushta, USSR,  
Vol. II pp. 290-297 (1991).

**91RO464**

ROSSAT-MIGNOD J., REGNAULT L.P., VETTIER C.,  
BURLET P., HENRY J.Y., LAPERTOT G.  
Inelastic neutron scattering study of superconducting  
 $\text{YBa}_2\text{Cu}_3\text{O}_{6+x}$  system.  
In "VI International School on Neutron Physics.  
Proceedings" held 8-18 October 1990 in Alushta, USSR,  
Vol. II pp. 322-327 (1991).

**91DU465**

DUBOIS J.M., DONG C., JANOT C., BOISSIEU M. DE,  
AUDIER M.

The reversible crystal-quasicrystal transitions in icosahedral Al-Cu-Fe alloys.

Phase Transitions **32**, 3-28 (1991).

**91LA466**

LAUTER H.J., GODFRIN H., FRANK V.L.P., LEIDERER P.

Neutron scattering studies of quantum films.

NATO ASI Series, Series B Physics **267**, 135-151 (1991).

**91ME467**

MEZEI F., LARTIGUE C., FARAGO B.

Neutron spin echo observation of spontaneous phonon decay in superfluid  $^4\text{He}$ .

NATO ASI Series, Series B Physics **257**, 119-120 (1991).

**91VI468**

VILCHES O.E., LIU F.C., KINGSBURY D.L., MA J., BIENFAIT M., SUZANNE J., GAY J.M., MARUYAMA M., ZEPPEFELD P., DEGENHARDT D., LAUTER H.J., RIEUTORD F., CODDENS G.

Search for a fluid phase in films of molecular hydrogen isotopes adsorbed on MgO.

NATO ASI Series, Series B Physics **257**, 477-488 (1991).

**91FR469**

FRANK V.L.P., LAUTER H.J., GODFRIN H., LEIDERER P.

Lattice dynamics of quantum gases adsorbed on graphite investigated by inelastic neutron scattering.

NATO ASI Series, Series B Physics **257**, 489-498 (1991).

**91LA470**

LAUTER H.J., WYATT A.F.G.

Final Discussion session.

NATO ASI Series, Series B Physics **257**, 589-593 (1991).

**91TR471**

TROUNOV V., KURBAKOV A., KRUTOV G., MATVEEV A., HEWAT A., ANTONSON O.

Peculiarities in temperature dependences of structural parameters of high- $T_c$  ceramics type 1-2-3 based on "zero"-matrix of samarium.

In "VI International School on Neutron Physics. Proceedings" held 8-18 October 1990 in Alushta, USSR, Vol. II pp. 347-355 (1991).

**91SU472**

SUCK J.B.

Neutron inelastic scattering from alloys with non-crystallographic point symmetries (quasicrystals).

In "VI International School on Neutron Physics. Proceedings" held 8-18 October 1990 in Alushta, USSR, Vol. I pp. 190-199 (1991).

**91MA473**

MAYERHOFER U., EGIDY T.VON, LINDNER H., HILLER H., KLORA J., TRIEB H., WALTER A.

The level scheme of  $^{198}\text{Au}$  studied with (d,p), (n, $\gamma$ ) and (n,e $^-$ ) reactions and the level scheme of  $^{196}\text{Au}$  studied with (d,t) and ( $^3\text{He},\alpha$ ) reactions

AIP Conference Proceedings **238**, 464-466 (1991).

**91MA474**

MARTINEZ J.L.

Spin fluctuations in Ni.

In "Spanish Scientific Research using Neutron Scattering Techniques", J.C. GOMEZ SAL et al. Eds. (Universidad de Cantabria, 1991) pp. 122-124.

**91KO475**

KONDUROV I.A., SUSHKOV P.A., BOGDANOVIC M., SIMIC J., SEYFARTH H., BAADER H.A., BREITIG D., KOCH R., BARREAU G., BOERNER H.G., BRISSOT R., KERR S., MAC MAHON T.D., MITSUNARI T., FAUST H., SCHRECKENBACH K.

The level scheme of  $^{110}\text{Ag}$  from the (n, $\gamma$ ) reaction.

AIP Conference Proceedings **238**, 421-424 (1991).

**91FI476**

FILLAUX F., CARLILE C.J., KEARLEY G.J.

Inelastic-neutron-scattering study at low temperature of the quantum sine-Gordon breather in 4-methyl-pyridine with partially deuterated methyl groups.

Physical Review **B 44**, 12280-12293 (1991).

**91PE477**

PENDLEBURY J.M.

Measuring the neutron lifetime using stored neutrons.

In "Proceedings of the XXVth Rencontre de Moriond", (Editions Frontières, 1991) pp. 357-363.

**91BU478**

BURKEL E., DORNER B., ILLINI T., PEISL J.

High-energy resolution in X-ray scattering with the spectrometer INELAX. I. The principles and the test instrument.

Journal of Applied Crystallography **24**, 1042-1050 (1991).

**91DU479**

DUPUY J., JAL J.F., CHIEUX P., DIANOUX A.J.

H-bond dynamics in well-characterized supercooled and glassy aqueous solutions.

Journal of Molecular Structure **250**, 315-328 (1991).

**91FO480**

FORD G.W., LEWIS J.T., O'CONNELL R.F.

Quantum tunneling in a blackbody radiation field.

Physics Letters **A 158**, 367-369 (1991).

**91MA481**

MARTINEZ J.L., CEBOLLADA A., GALLEGO J.M., MIGUEL J.J. DE, OCAL C., MIRANDA R., FERRER S.  
Neutron-diffraction study on the antiferromagnetic ordering in Co-Cu superlattices  
In "Spanish Scientific Research using Neutron Scattering Techniques", J.C.GOMEZ SAL et al. Eds ( Universidad de Cantabria, 1991) pp. 145-147

**91TE482**

TERECH P.  
Structures of physical surfactant organogels : Connections with biological systems  
AIP Conference Proceedings **226**, 518-527 (1991).

**91TE483**

TERECH P.  
Surfactant organogels studied by small angle neutron scattering.  
Polymer Preprints **32**, 437-438 (1991).

**91BL484**

BLANCO J.A., GIGNOUX D., SCHMITT D., VETTIER C.  
Field induced magnetic structures in TbNi<sub>2</sub>Si<sub>2</sub>  
Journal of Magnetism and Magnetic Materials **97**, 4-14 (1991).

**91ST485**

STEINBINDER D., WIPF H., DIANOUX A.J., MAGERL A., RICHTER D., NEUMAIER K., HEMPELMANN R.  
Low temperature tunneling and quantum diffusion of hydrogen Nb(NH)<sub>x</sub>  
Journal of the Less Common Metals **172-174**, 685-692 (1991).

**91KU486**

KULDA J.  
The RED extinction model. III. The case of pure primary extinction  
Acta Crystallographica A **47**, 775-779 (1991).

**91PE487**

PENDLEBURY M.  
A challenging time for the ILL  
Nuclear Physics News **1**, n°6, 28 (1991).

**91RI488**

RIPERT M., PANNETIER J.S, CHABRE Y., POINSIGNON C.  
Manganese dioxides : Structural model and in-situ neutron powder diffraction investigation of thermal annealing and electrochemical reduction.  
Materials Research Society Symposium Proceedings **210**, 359-365 (1991).

**91FA489**

FAK B., ANDERSEN K.H.  
Neutron inelastic scattering from superfluid <sup>4</sup>He beyond the roton minimum.  
Physics Letters A **160**, 468-472 (1991).

**91BE490**

BERMEJO F.J., MARTINEZ J.L., MARTIN D., GARCIA-HERNANDEZ M., MOMPEAN F.J., ALONSO J.  
Observation of propagating collective excitations in liquid SO<sub>2</sub>.  
Journal of Chemical Physics **95**, 5387-5391 (1991).

**91BO491**

BOUCHENEB N., ASGHAR M., BARREAU G., DOAN T.P., LEROUX B., SICRE A., GELTENBORT P., OED A.  
A high-resolution multi-parametric study of <sup>239</sup>Pu(*n*<sub>th</sub>,f) with the Cosi-Fan-Tutte spectrometer.  
Nuclear Physics A **535**, 77-93 (1991).

**91MI492**

MIREBEAU I., BELLOUARD C., HENNION M., JEHANNO G., CAIGNAERT V., DIANOUX A.J., PHILLIPS T.E., MOORJANI K.  
Coexistence of antiferromagnetic order and spin glass freezing in YBa<sub>2</sub>(Cu<sub>0.88</sub>Fe<sub>0.12</sub>)<sub>3</sub>O<sub>6.5</sub>.  
Physica C **184**, 299-310 (1991).

**91BE493**

BERNAS M., ARMBRUSTER P., CZAJKOWSKI S., FAUST H., BOCQUET J.P., BRISSOT R.  
Discovery of neutron-rich Co and Fe isotopes in <sup>239</sup>Pu(*n*<sub>th</sub>,f) : Yields and half-lives  
Physical Review Letters **67**, 3661-3664 (1991).

**91KE494**

KEINONEN J., KURONEN A., TIKKANEN P., BOERNER H.G., JOLIE J., ULBIG S., KESSLER E.G., NIEMINEN R.M., PUSKA M.J., SEITSONEN A.P.  
First-principles simulation of intrinsic collision cascades in KCl and NaCl to test interatomic potentials at energies between 5 and 350 eV  
Physical Review Letters **67**, 3692-3695 (1991).

**91DA495**

DAY P.  
Mixed valency systems : Retrospect and prospect  
NATO ASI Series, Series C Mathematical and Physical Sciences **343** 1-6 (1991).

**91BR496**

BROKMEIER H.G., KLATT M., RITTER C.  
Zur phasenentwicklung pulvermetallurgisch hergestellter Ti-aluminide.  
Zeitschrift für Kristallographie, Supplement issue n°3, 35 (1991).

**91SU497**

SUN B.N., BOUTELLIER R., SCIAU P., BURKHARDT E., RODRIGUEZ V., SCHMID H.  
High temperature solution growth of perovskite Pb<sub>2</sub>CoWO<sub>6</sub>.  
Journal of Crystal Growth **112**, 71-83 (1991).

**91LI498**

LIRZIN A. LE, SOUBEYROUX J.L., TRESSAUD A., GEORGES R., DARRIET J.  
Systèmes magnétiques de basse dimensionnalité dans les fluorures de type usovite et jarlite.  
*Journal de Chimie Physique* **88**, 2173-2189 (1991).

**91RO499**

ROSSAT-MIGNOD J., REGNAULT L.P., VETTIER C., BOURGES P., BURLET P., BOSSY J., HENRY J.Y., LAPERTOT G.  
Neutron scattering study of the  $\text{YBa}_2\text{Cu}_3\text{O}_{6+x}$  system.  
*Physica C* **185-189**, 86-92 (1991).

**91FO500**

FORGAN E.M., PAUL D. MCK., MOOK H.A., LEE S.L., CUBITT R., ABELL J.S., GENGER F., TIMMINS P.  
Neutron diffraction from the flux line lattice.  
*Physica C* **185-189**, 247-252 (1991).

**91CH501**

CHAILLOUT C., CHMAISSEN O., CAPPONI J.J., FOURNIER T., MCINTYRE G.J., MAREZIO M.  
The structure of superconducting  $\text{Pb}_2\text{Sr}_2\text{Y}_{1-x}\text{Ca}_x\text{Cu}_3\text{O}_8$  by single crystal neutron diffraction data.  
*Physica C* **185-189**, 635-636 (1991).

**91CA502**

CALDES M.T., FUERTES A., GOMEZ P., RODRIGUEZ J.  
Lanthanum substitution in the tubular phase  $\text{Bi}_4\text{Sr}_8\text{Cu}_5\text{O}_{19+y}$ . Neutron diffraction of  $\text{Bi}_4\text{Sr}_{8-x}\text{La}_x\text{Cu}_5\text{O}_{19+y}$ .  
*Physica C* **185-189**, 681-682 (1991).

**91GU503**

GUILLAUME M., ALLENSPACH P., MESOT J., STAUB U., FURRER A., TRUNOV V., KURBAKOV A., BLANK H., MUTKA H.  
Evidence for intermediate valence Sm ions in  $\text{SmBa}_2\text{Cu}_3\text{O}_x$ .  
*Physica C* **185-189**, 819-820 (1991).

**91GA504**

GARCIA-MUNOZ J.L., OBRADORS X., KILCOYNE S.H., CYWINSKI R.  
A  $\mu\text{SR}$  search for localized moments in  $\text{YBa}_2(\text{Cu}_{1-x}\text{Zn}_x)_3\text{O}_7$ .  
*Physica C* **185-189**, 1085-1086 (1991).

**91GR505**

DE GROOT P.A.J., YOUNG T., RAINFORD B.D., WELLER M.T., GRASMEDER J.R., SCHAEERPF O.  
Return of antiferromagnetic long range order upon La doping in  $\text{YBa}_2\text{Cu}_3\text{O}_{7+y}$ .  
*Physica C* **185-189**, 1169-1170 (1991).

**91GA506**

GARCIA-MUNOZ J.L., RODRIGUEZ-CARVAJAL J., SCHAEERPF O., OBRADORS X., KILCOYNE S.H., CYWINSKI R.  
The nature of magnetic order in  $\text{YBa}_2(\text{Cu}_{0.9}\text{Fe}_{0.1})_3\text{O}_{7.2}$ : A neutron polarisation analysis study.  
*Physica C* **185-189**, 1173-1174 (1991).

**91AN507**

ANSALDO E.J., NIEDERMAYER C., GLUECKLER H., STRONACH C.E., RISEMAN T.M., CARY R.S., NOAKES D.R., OBRADORS X., FUERTES A., NAVARRO J.M., GOMEZ P., CASAN N., MARTINEZ B., PEREZ F., RODRIGUEZ-CARVAJAL J., CHOW K.  
Superconductivity and magnetic order in superoxygenated  $\text{La}_2\text{MCu}_2\text{O}_{6+\delta}$  (M=Ca, Sr).  
*Physica C* **185-189**, 1213-1214 (1991).

**91FE508**

FERNANDEZ-DIAZ M.T., MARTINEZ J.L., RODRIGUEZ-CARVAJAL J., ODIER P., FILLION G., BEILLE J., BARBARA B., CYROT M.  
Magnetic field induced transitions in  $\text{Pr}_2\text{NiO}_4$  single crystals.  
*Physica C* **185-189**, 1225-1226 (1991).

**91PA509**

PAUL D. MCK., FORGAN E.M., MOOK H.A., CUBITT R., LEE S.L., NORTON M.L., TANG H.Y., TIMMINS P.  
Anomalous neutron scattering from the flux-line lattice in  $\text{K}_{0.4}\text{Ba}_{0.6}\text{BiO}_3$ .  
*Physica C* **185-189**, 1837-1838 (1991).

**91MA510**

MACCHI F., DAUDIN B., ERMOLIEFF A., MARTHON S., LEGRAND J.F.  
Chemical defects induced in P(VDF-TrFe) by electron irradiation.  
*Radiation Effects and Defects in Solids* **118**, 117-124 (1991).

**91DO511**

DONG C., DUBOIS J.M., BOISSIEU M. DE, BOUDARD M., JANOT C.  
Growth of stable Al-Pd-Mn icosahedral phase.  
*Journal of Materials Research* **6**, 2637- 2645 (1991).

**91WU512**

WUTTKE J., LIPOWSKY R.  
Universality classes for wetting in two-dimensional random-bond systems.  
*Physical Review B* **44**, 13042-13052 (1991).

**91UL513**

ULBIG S., LIEB K.P., BOERNER H.G., JOLIE J., ROBINSON S.J., BOOTEN J.G.L., DEWEY M.S., WINTER C.  
Lifetime studies of  $2p_{1f}$  shell nuclei by means of the grid technique  
In "Proceedings of the 25th Zakopane School of Physics Vol. 2", J. Styczen, Z. Stachura Eds. (1990) pp. 136-151

**91ZA514**

ZACCAI G.

Les molécules passées au crible des neutrons.

Biofutur **102**, 37-42 (1991).**91ST515**

STUHR U., WIPF H., VETTIER C., SCHOBER H.R.

Lattice-parameter dependence of the diffusivity of hydrogen in niobium at low temperatures.

Solid State Communications **80**, 987-989 (1991).**91PR516**

PRIETO C., ANDRES A. DE, MEDARDE M., MARTINEZ J.L., FERNANDEZ-DIAZ M.T., RODRIGUEZ-CARVAJAL J., SAEZ-PUCHE R., FERNANDEZ F.

EXAFS and Raman study of stoichiometric and oxidized  $\text{Nd}_2\text{NiO}_{4+\delta}$ .Solid State Communications **80**, 975-980 (1991).**91HE517**HEMPELMANN R., PRICE D.L., REITER G., RICHTER D.  
Hydrogen potential in  $\beta$ -V<sub>2</sub>H studied by deep inelastic neutron scattering.Journal of the Less-Common Metals **172-174**, 301-306 (1991).**91JO518**

JOLIE J., HEYDE K.

A consistent description of the mixing of intruder and normal states in  $^{114}\text{Cd}$ .AIP Conference Proceedings **238**, 143-145 (1991).**91JO519**

JOLIE J.

Recent progress in the application of extended supersymmetries to odd-odd nuclei in the Au region.

AIP Conference Proceedings **238**, 146-149 (1991).**91BO520**

BOERNER H.G., JOLIE J., ROBINSON S.J., KESSLER E.G., ULBIG S., CASTEN R.F., DEWEY S.M., GREENE G., DESLATTES R., LIEB K.P., KRUSCHE B., CIZEWSKI J.A.

Gamma ray induced Doppler broadening and the determination of lifetimes of excited nuclear states.

AIP Conference Proceedings **238**, 173-188 (1991).**91JO521**

JOLIE J., BOERNER H.G., ROBINSON S.J.

Analysis of recoil Doppler profiles obtained with ultra high resolution (n, $\gamma$ ) spectroscopy.AIP Conference Proceedings **238**, 189-198 (1991).**91KE522**

KESSLER E.G., DEWEY M.S., GREENE G.L., DESLATTES R.D., BOERNER H.G.

Precise absolute  $\gamma$ -ray wavelength measurements.AIP Conference Proceedings **238**, 199-209 (1991).**91RO523**

ROBINSON S.J., JOLIE J., COPNELL J.

Mixed symmetry states in nuclei near closed shells.

AIP Conference Proceedings **238**, 210-217 (1991).**91HO524**

HOYLER F., FOEHL K., BOERNER H.G., KRUSCHE B., ROBINSON S.J., SCHILLEBEECKX P.

Features of the level schemes of  $^{164-166}\text{Dy}$ .AIP Conference Proceedings **238**, 257-262 (1991).**91UL525**

ULBIG S., JOLIE J., BOERNER H.G., DEWEY M.S., LIEB K.P., ROBINSON S.J.

GRID lifetime study of the 1762 KeV state in  $^{49}\text{Ti}$  populated via cascade feeding.AIP Conference Proceedings **238**, 396-398 (1991).**91MI526**

MICHAELSEN S., LIEB K.P., ROBINSON S.J.

Level density in  $^{51}\text{V}$  at spin 9/2-15/2 measured with the  $^{50}\text{V}(n,\gamma)$  reaction.AIP Conference Proceedings **238**, 399-403 (1991).**91UL527**ULBIG S., LIEB K.P., BOERNER H.G., ROBINSON S.J.  
GRID lifetime measurements and shell model calculations in  $^{59}\text{Ni}$ .AIP Conference Proceedings **238**, 407-411 (1991).**91JO528**

JOLIE J., HOYLER F., KRUSCHE B.

Measurement of conversion electrons from the  $^{75}\text{As}(n,e^-)$  reaction. A test of the description of  $^{76}\text{As}$  in the  $U_{\nu}(6/12)XU_{\pi}(6/12)$  scheme.AIP Conference Proceedings **238**, 412-414 (1991).**91RO529**

ROBINSON S.J., BOERNER H.G., JUDGE S., JOLIE J., SCHILLEBEECKX P.

Detailed spectroscopy of  $^{144}\text{Nd}$ .AIP Conference Proceedings **238**, 440-442 (1991).**91RO530**

ROBINSON S.J.

Extraction of spins and mixing ratios from directional correlation data.

AIP Conference Proceedings **238**, 443-445 (1991).**91KL531**

KLORA J., BOERNER H.G., EGIDY T. VON, HILLER H., JUDGE S., KRUSCHE B., LIBMAN V.A., LINDNER H., LITVINSKY L.L., MAYERHOFER U., MURZIN A.V., ROBINSON S.J.

Nuclear structure investigations and lifetime measurements in  $^{156}\text{Gd}$ .AIP Conference Proceedings **238**, 455-457 (1991).

**91WH532**

WHITE D.H., HOFF R.W., BOERNER H.G., COLVIN G., HOYLER F., SCHRECKENBACH K.

Nuclear structure of  $^{241}\text{Pu}$  from (n, $\gamma$ ) and (n,e) reaction measurements.

AIP Conference Proceedings **238**, 476-478 (1991).

**91KR533**

KRUSCHE B.

Statistical description of the  $\gamma$ -ray cascades after thermal neutron capture.

AIP Conference Proceedings **238**, 610-613 (1991).

**91BI534**

BITTER T., EISERT F., EL-MUZEINI P., KESSLER M., KINKEL U., KLEMT E., LIPPERT W., WERNER R., DUBBERS D., GOBRECHT K., BALDO-CEOLIN M., BOBISUT F., GIBIN D., GUGLIELMI A., LAVEDER M., MATTIOLI F., MEZZETTO M., PUGLIERIN G., SCONZA A., VASCON M., VISENTIN L., BENETTI P., CALLIGARICH E., DOLFINI R., GENONI M., GIGLI BERZOLARI A., MAURI F., PIAZZOLI A., RAPPOLDI A., RASELLI G.L., SCANNICCHIO D.

Neutron-antineutron oscillation experiment : Results and perspectives.

AIP Conference Proceedings **238**, 805-807 (1991).

**91KR535**

KRUSCHE B.

Experiments with (n, $\gamma$ )-( $\gamma$ , e $^+$ e $^-$ ) converters.

AIP Conference Proceedings **238**, 943-952 (1991).

**91BA536**

BATTLE P.D., JONES C.W., STUDER F.

The crystal and magnetic structures of  $\text{Ca}_2\text{NdRuO}_6$ ,  $\text{Ca}_2\text{HoRuO}_6$  and  $\text{Sr}_2\text{ErRuO}_6$ .

Journal of Solid State Chemistry **90**, 302-312 (1991).

**91SA537**

SANDONIS J., BARUCHEL J.

Topographic studies of antiferromagnetic single crystals. In "Spanish Scientific Research Using Neutron Scattering Techniques"

J.C. GOMEZ SAL et al. Eds. (Universidad de Cantabria, 1991) pp. 96-102

**91MA538**

MARMEGGI J.C.

Contribution of white beam diffraction to the investigation of modulated phase transitions.

In "Methods of Structural Analysis of Modulated Structures and Quasicrystals", Proceedings of the International Workshop held at Lekeitio-Bilbao, Spain, April 29 -May 4, 1991 (World Scientific, 1991) pp. 448-452.

**91RO539**

RODRIGUEZ V., COUZI M., GOMEZ-CUEVAS A., CHAMINADE J.P.

On the structural phase transitions in the incommensurate  $\text{Cs}_2\text{CdBr}_4$ .

Phase Transitions **31**, 75-91 (1991).

**91RO540**

RODRIGUEZ V., COUZI M., SOURISSEAU C., TRESSAUD A., GRANNEC J., CHAMINADE J.P., SOUBEYROUX J.L., ECOLIVET C.

Structural phase transition in the ordered fluorides  $\text{M}^{\text{II}}\text{ZrF}_6$  ( $\text{M}^{\text{II}} = \text{Co}, \text{Zn}$ ).

Phase Transitions **33**, 85-90 (1991).

**91BL541**

BLASE W., CORDIER G., VOGT T.

Darstellung und Kristallstruktur von  $\text{Na}_{28}\text{In}_{14}\text{Sn}_{15}$ . Zeitschrift für Anorganische und Allgemeine Chemie

**606**, 79-90 (1991).

**91AG542**

AGERON P.

Neutronic design of the ILL cold sources. An historical perspective.

in "Cold Neutron Sources", G.J. RUSSELL, C.D. WEST Eds. International Workshop held at Los Alamos, NM, USA, March 5-8, 1990 (Report LA-12146-C, UC-413, August 1991) pp. 1-17.

**91GO543**

GOBRECHT K.

The ILL cold sources

in "Cold Neutron Sources", G.J. RUSSELL, C.D. WEST Eds. International Workshop held at Los Alamos, NM, USA, March 5-8, 1990 (Report LA-12146-C, UC-413, August 1991) pp. 19-30.

**91AG544**

AGERON P.

An alternative in the heat transfer design : A cold neutron source without vacuum insulation

in "Cold Neutron Sources", G.J. RUSSELL, C.D. WEST Eds. International Workshop held at Los Alamos, NM, USA, March 5-8, 1990 (Report LA-12146-C, UC-413, August 1991) pp. 291-297.

**91PO545**

PONTONNIER L., FRUCHART D., SOUBEYROUX J.L., TRIANTAFILLIOIS G., BERTHIER Y.

Structural and magnetic behaviour of  $\text{LuF}_2\text{H}_x$ .

Journal of the Less-Common Metals **172-174**, 191-197 (1991).

**91WE546**

WEISS E., CORBELIN S., COCKCROFT J.K., FITCH A.N.

Darstellung und Struktur von Methylnatrium. Strukturbestimmung an  $\text{NaCD}_3$ -Pulvern bei 1.5 und 300 K durch Neutronen- und Synchrotronstrahlenbeugung.

Chemische Berichte **123**, 1629-1634 (1991).

**91HO547**

HOWELL I., NEILSON G.W., CHIEUX P.  
Neutron diffraction studies of ions in aqueous solution  
*Journal of Molecular Structure* **250**, 281-289 (1991).

**91GR548**

GRATZ E., LOEWENHAUPT M., DIVIS M., STEINER W., BAUER E., PILLMAYR N., MUELLER H., NOWOTNY H., FRICK B.  
Structural, magnetic, electronic and transport properties of NdCu<sub>2</sub>.  
*Journal of Physics : Condensed Matter* **3**, 9297-9318 (1991).

**91MA549**

MAYERHOFER U., EGIDY T.V., JOLIE J., BOERNER H.G., COLVIN G., JUDGE S., KRUSCHE B., ROBINSON S.J., SCHRECKENBACH K., BRANT S., PAAR V.  
The experimental structure of <sup>199</sup>Au and the interacting boson-fermion model.  
*Zeitschrift für Physik A. Hadrons and Nuclei* **341**, 1-8 (1991).

**91FY550**

FYODOROV Y.V., SHENDER E.F.  
Random-field effects in antiferromagnets with classically degenerate ground states  
*Journal of Physics : Condensed Matter* **3**, 9123-9128 (1991).

**91AL551**

ALONSO J., BERMEJO F.J., GARCIA-HERNANDEZ M., MARTINEZ J.L., HOWELLS W.S.  
H-bond in methanol : A molecular dynamics study.  
*Journal of Molecular Structure* **250**, 147-170 (1991).

**91MA552**

MARTIN-MARERO D., BERMEJO F.J., MARTINEZ J.L., BATALLAN F., GARCIA-HERNANDEZ M., MOMPEAN F.J.  
High frequency excitations in a molecular glass.  
*Journal of Molecular Structure* **250**, 413-419 (1991).

**91AL553**

ALONSO J., BERMEJO F.J., GARCIA-HERNANDEZ M., MARTINEZ J.L., HOWELLS W.S.  
A Molecular dynamics study of collective excitations in liquid methanol.  
Report RAL-91-083, pp. 1-27 (1991).

**91TA554**

TAILLEFER L., BEHNIA K., HASSELBACH K., FLOUQUET J., HAYDEN S.M., VETTIER C.  
On the superconducting phase transitions of UPt<sub>3</sub>.  
*Journal of Magnetism and Magnetic Materials* **90-91**, 623-627 (1990).

**91BO555**

BOERNER H.G., JOLIE J., ROBINSON S.J., GILL R.L., CASTEN R.F.  
New reactor based methods to measure short lifetimes of nuclear excited states.  
*Neutron News* **2**, n°4, 20-23 (1991).

**91AR556**

ARMBRUSTER P.  
Das Feuer hüten, das Neutronen gibt.  
In "Wie kommt man auf einfaches Neues? Der Forscher, Lehrer, Wissenschaftspolitiker und Hobbykoch Heinz Maier-Leibnitz", P. Kienle Ed., (Interfrom Ed., 1991) pp. 107-116.

**91BE557**

BELLET D., BASTIE P.  
Temperature dependence of the lattice parameter of the  $\gamma$  and  $\gamma'$  phases in the nickel-based superalloy CMSX-2. Part I : Observation of a tetragonal distortion of the  $\gamma'$  phase at high temperature by  $\gamma$ -ray diffractometry.  
*Philosophical Magazine* **B 64**, 135-141 (1991).

**91BE558**

BELLET D., BASTIE P.  
Temperature dependence of the lattice parameter of the  $\gamma$  and  $\gamma'$  phases in the nickel-based superalloy CMSX-2. Part II : Neutron diffraction study of the lattice parameter mismatch.  
*Philosophical Magazine* **B 64**, 143-152 (1991).

**91CA559**

CALDES M.T., NAVARRO J.M., FUERTES A., OBRADORS X., MIRAVITLLES C., RODRIGUEZ-CARVAJAL J., VALLET M., GONZALES-CALBET J.  
High resolution neutron powder diffraction study of the tubular phase Bi<sub>4</sub>Sr<sub>8</sub>Cu<sub>5</sub>O<sub>19+x</sub>.  
*Materials Research Society Symposium Proceedings* **169**, 133-136 (1990).

**91NO560**

NOZIERES P.  
Shape and growth of crystals.  
In "Solids far from equilibrium", C. Godrèche Ed. (Cambridge University Press, 1991) pp. 1-154.

**91BA561**

BANFI G.P., DEGIORGIO V., RIGHINI G.C., RENNIE A.R.  
Measurement of the sizes of the semiconductor crystallites in colored glasses through neutron scattering  
*SPIE Proceedings* **1361**, 874-880 (1991).

**91JA562**

JANOT C.  
The structure of quasicrystals. An introduction  
In "Methods of Structural Analysis of Modulated Structures and Quasicrystals", Proceedings of the International Workshop held at Lekeitio-Bilbao, Spain, April 29 -May 4, 1991 (World Scientific, 1991) pp. 20-46.

**91JA563**

JANOT C.  
Contrast variation for N-dimensional crystallography  
In "Methods of Structural Analysis of Modulated Structures

and Quasicrystals”, Proceedings of the International Workshop held at Lekeitio-Bilbao, Spain, April 29 -May 4, 1991 (World Scientific, 1991) pp. 294-312.

**91PA564**

PAPOULAR R.J., BOISSIEU M. DE, JANOT C.  
The maximum entropy method in quasicrystallography  
In “Methods of Structural Analysis of Modulated Structures and Quasicrystals”, Proceedings of the International Workshop held at Lekeitio-Bilbao, Spain, April 29 -May 4, 1991 (World Scientific, 1991) pp. 333-343.

**91HE565**

HEWAT A.W.  
Modulated structures of High  $T_c$  superconductors.  
In “Methods of Structural Analysis of Modulated Structures and Quasicrystals”, Proceedings of the International Workshop held at Lekeitio-Bilbao, Spain, April 29 -May 4, 1991, (World Scientific, 1991) pp. 456-465.

**91BO566**

BOUDARD M., JANOT C., BOISSIEU M. DE, DUBOIS J.M., DONG C.  
The structure of the icosahedral AlPdMn quasicrystal  
In “Methods of Structural Analysis of Modulated Structures and Quasicrystals” Proceedings of the International Workshop held at Lekeitio-Bilbao, Spain, April 29 -May 4, 1991 (World Scientific, 1991) pp. 515-520

**2 - without ILL authors or coauthors  
(From code number 1001):**

**91MO1001**

MORISHIGE K., TAJIMA Y., KITAKA S., CLARKE S.M., THOMAS R.K.  
The structure of chloromethane monolayers adsorbed on graphite.  
Molecular Physics **72**, 395-411 (1991).

**91BA1002**

BARHAM P.J., SADLER D.M.  
A neutron scattering study of the melting behaviour of polyethylene single crystals.  
Polymer **32**, 393-395 (1991).

**91BA1003**

BATTLE P.D., BOLLEN S.K., GIBB T.C., MATSUO M.  
The crystal and magnetic structures of  $\text{Ca}_2\text{Cr}_{0.5}\text{Fe}_{1.5}\text{O}_5$  at 2.1 K.  
Journal of Solid State Chemistry **90**, 42-46 (1991).

**91CL1004**

CLARKE S.M., THOMAS R.K.  
The structure of a bromomethane monolayer adsorbed on graphite.  
Molecular Physics **72**, 413-423 (1991).

**91IN1005**

INABA A., CHIHARA H., CLARKE S.M., THOMAS R.K.  
The structure and heat capacity of fluoromethane monolayers adsorbed on graphite.  
Molecular Physics **72**, 109-120 (1991).

**91KA1006**

KALUS J.  
Shear induced phase transition and transient small angle neutron scattering experiments on micellar solutions.  
Molecular Crystals and Liquid Crystals **193**, 77-81 (1990).

**91LA1007**

LANDER G.H.  
Sleuthing in reciprocal space : the search for a charge-density wave in  $\alpha$ -uranium.  
Endeavour New Series, **14**, 179-184 (1990).

**91MC1008**

MCEWEN K.A., STEIGENBERGER U., JENSEN J.  
Spin waves, phonons, and crystal-field excitations in thulium.  
Physical Review **B 43**, 3298-3310 (1991).

**91FI1009**

FINK D., MUELLER M., WANG L.  
Reconstruction of three-dimensional range distributions by a modified tomographic technique.  
Journal of Applied Physics **68**, 958-964 (1990).

**91FI1010**

FINK D., WANG L.  
On the thermal annealing behavior of boron in solids.  
Radiation Effects and Defects in Solids **114**, 343-371 (1990).

**91FI1011**

FINK D., WANG L., BIERSACK J.P., JAHNEL F.  
30 keV to 2 MeV boron implantation profiles in solids.  
Radiation Effects and Defects in Solids **115**, 93-112 (1990).

**91FI1012**

FINK D., MUELLER M., WANG L., SIEGEL J., VREDENBERG A., MARTAN J., FAHRNER W.  
Energy, fluence and temperature dependence of MeV nitrogen implantation profiles in steel.  
Radiation Effects and Defects in Solids **115**, 121-134 (1990).

**91GO1013**

GOODWIN J.W., OTTEWILL R.H.  
Properties of concentrated colloidal dispersions.  
Journal of the Chemical Society Faraday Transactions **87**, 357-369 (1991).

**91BA1014**

BARNES P.  
Neutron diffraction studies on industrial materials.  
Nondestructive Testing and Evaluation **5**, 319-334 (1990).

**91RA1015**

RAMSEY N.F.  
Electric dipole moment of the neutron.  
Annual Review of Nuclear and Particle Science **40**, 1-14, 1990.

**91SM1016**

SMALLEY M.V., BALL P.C.  
The group theory of trigonal and tetrahedral molecule rotations in trigonal and tetrahedral crystal fields.  
Molecular Physics **71**, 1233-1249 (1990).

**91SM1017**

SMALLEY M.V.  
Electrostatic interaction in macro-ionic solutions and gels.  
Molecular physics **71**, 1251-1267 (1990).

**91CR1018**

CRAWFORD R.J., SMALLEY M.V., THOMAS R.K.  
The effect of uniaxial stress on the swelling of n-butylammonium vermiculite.  
Advances in Colloid and Interface Science **34**, 537-560 (1991).

**91RA1019**

RAVEY J.C., STEBE M.J.  
Structure of inverse micelles and emulsion-gels with fluorinated nonionic surfactants. A small-angle neutron scattering study.  
Progress in Colloid and Polymer Science **82**, 218-228 (1990).

**91RO1020**

ROBL C., KUHS W.F.  
A neutron diffraction study on hydrogen bonding in the mineral mellite ( $\text{Al}_2[\text{C}_6(\text{COO})_6] \cdot 16\text{H}_2\text{O}$ ) at 15 K.  
Journal of Solid State Chemistry **92**, 101-109 (1991).

**91MU1021**

MUELLER M., FINK D.  
Reconstruction of submicron size spatial distributions of implanted particles in solids by computer tomography.  
Nuclear Instruments and Methods in Physics Research **B 34**, 162-165 (1988).

**91MA1022**

MAHJOUB A.R., HOSER A., FUCHS J., SEPPELT K.  
The structure of  $\text{BrF}_6^-$  and related compounds.  
Angewandte Chemie. International Edition English **28**, 1526-1527 (1989).

**91MC1023**

MCGREEVY R.L., HOWE M.A.  
The structure of molten  $\text{LiCl}$ .  
Journal of Physics : Condensed Matter **1**, 9957-9962 (1989).

**91FI1024**

FITCH A.N., COLE M.  
The structure of  $\text{K}_2\text{UO}_2\text{PO}_4 \cdot 3\text{D}_2\text{O}$  refined from neutron and synchrotron-radiation powder diffraction data.  
Materials Research Bulletin **26**, 407-414 (1991).

**91BR1025**

BROOKS M.S.S., LANDER G.H., JOHANSSON B.  
Orbital magnetism from itinerant electrons.  
Europhysics News **22**, 87-89 (1991).

**91LE1026**

LEBECH B., WULFF M., LANDER G.H.  
Spin and orbital moments in actinide compounds.  
Journal of Applied Physics **69**, 5891-5896 (1991).

**91WE1027**

WEBSTER P.J.  
Neutron strain scanning.  
Neutron News **2**, n°2, 19-22 (1991).

**91DU1028**

DUNSTETTER F., PLAKHTY V., SCHWEIZER J.  
Magnetic correlations in  $\gamma$ -oxygen : A neutron polarisation study.  
Journal of Magnetism and Magnetic Materials **96**, 282-290 (1991).

**91GR1029**

GRIMES R.W., FITCH A.N.  
Thermal decomposition of cobalt(II) acetate tetrahydrate studied with time-resolved neutron diffraction and thermogravimetric analysis.  
Journal of Materials Chemistry **1**, 461-468 (1991).

**91LA1030**

LANDER G.H., BROOKS M.S.S., JOHANSSON B.  
Orbital band magnetism in actinide intermetallics.  
Physical Review **B 43**, 13672-13675 (1991).

**91JO1031**

JOBIC H., SANTINI C.C., COULOMBEAU C.  
Vibrational modes of acetylenedicobalt hexacarbonyl studied by neutron spectroscopy.  
Inorganic Chemistry **30**, 3088-3090 (1991).

**91KU1032**

KUSCHKE W. M., SCHULTZ L., LAMPARTER P., STEEB S.  
X-Ray and neutron diffraction of amorphous nickel-zirconium-alloys as prepared in different ways.  
Zeitschrift für Naturforschung **46 a**, 491-498 (1991).

**91HE1033**

HEURTEAUX C., RIPOLL C., OUZNADJI S., OUZNADJI H., WISSOCQ J.C., THELLIER M.  
Lithium transport in the mouse brain.  
Brain Research **547**, 122-128 (1991).

**91DE1034**

DERIU A., CAVATORTA F., CABRINI D., MIDDENDORF H.D.

Molecular structure and dynamics of biopolymer gels by neutron scattering.  
Progress in Colloid and Polymer Science **84**, 461-464 (1991).

**91EI1035**

EICHHORN K.D.  
Neutron structure analysis of 1-hydroxypyridinium trichloroacetate,  $C_7H_6Cl_3NO_3$ , at 120 K.  
Zeitschrift für Kristallographie **195**, 205-220 (1991).

**91MC1036**

MCMAHON M.I., NELMES R.J., KUHS W.F., SEMMINGSEN D.  
The effect of deuteration on the crystal structure of squaric acid ( $H_2C_4O_4$ ) in its ordered phase.  
Zeitschrift für Kristallographie **195**, 231-239 (1991).

**91PI1037**

PILTZ R.O., MCMAHON M.I., NELMES R.J.  
Deuteration and pressure effects on the crystal structure of paraelectric  $NH_4H_2PO_4$ .  
Zeitschrift für Kristallographie **195**, 241-249 (1991).

**91NO1038**

NORBY P., CHRISTENSEN A.N., FJELLVAG H., NIELSEN M.  
The crystal structure of  $Cr_8O_{21}$  determined from powder diffraction data : Thermal transformation and magnetic properties of a chromium-chromate-tetrachromate.  
Journal of Solid State Chemistry **94**, 281-293 (1991).

**91HE1039**

HEAP R.T., MITCHELL P.W., TAYLOR A.D., OSBORN R.  
High-energy magnetic excitations in chromium.  
Physica **B 174**, 22-24 (1991).

**91RE1040**

REID B.L., MITCHELL P.W., CAUDRON R., RAINFORD B.D., MCCAUSLAND M.A.H., BOOTHROYD A.T.  
Magnetic properties of holmium in yttrium.  
Physica **B 174**, 39-42 (1991).

**91GR1041**

GRIMM H., RUPPRECHT A.  
Statics and dynamics of oriented DNA as seen by neutrons.  
Physica **B 174**, 291-299 (1991).

**91KO1042**

KOLLMAR A., SEEGER A., SCHALT W., THYSSEN H.  
A time-of-flight neutron spin echo spectrometer.  
Physica **B 174**, 528-531 (1991).

**91OT1043**

OTTEWILL R.H.  
Small-angle neutron scattering from colloidal dispersions.  
Journal of Applied Crystallography **24**, 436-443 (1991).

**91JO1044**

JOBIC H., BEE M., CARO J., BUELOW M., KAERGER J., PFEIFER H.  
Microdynamics of guest molecules in zeolites studied by quasi-elastic neutron scattering and NMR pulsed field gradient technique.  
In "Catalysis and Adsorption by Zeolites", G. Öhlmann et al. Eds. (Elsevier, 1991) pp. 445-455.

**91CZ1045**

CZJZEK M., JOBIC H., BEE M.  
Molecular dynamics of xylene in Na, Yb-Y and ZSM-5 studied by quasi-elastic neutron scattering.  
Journal of the Chemical Society Faraday Transactions **87**, 3455-3459 (1991).

**91FE1046**

FERNANDEZ BARQUIN L., RODRIGUEZ FERNANDEZ J., GOMEZ SAL J.C., GUTIERREZ J., BARANDIARAN J.M.  
Study of the low-temperature resistivity behavior in Co-Si-B metallic glasses : magnetic and neutron diffraction characterization.  
Journal of Magnetism and Magnetic Materials **101**, 52-54 (1991).

**91KU1047**

KUSCHKE W.M., LAMPARTER P., STEEB S.  
Local structure of the amorphous  $Ni_{25}Zr_{75}$ -alloy by using the isotope-substitution neutron diffraction method.  
Zeitschrift für Naturforschung **46a**, 951-954 (1991).

**91CO1048**

COLLINS D.R., FITCH A.N., CATLOW C.R.A.  
Time-resolved powder neutron diffraction study of thermal reactions in clay minerals.  
Journal of Materials Chemistry **1**, 965-970 (1991).

**91KO1049**

KORITSANSZKY T., BUSCHMANN J., DENNER L., LUGER P., KNOEHEL A., HAARICH M., PATZ M.  
Low-temperature X-ray and neutron diffraction studies on 18-crown-6•2 cyanamide including electron density determination.  
Journal of the American Chemical Society **113**, 8388-8398 (1991).

**91SM1050**

SMITH K.F., NOLAN K.F., REID K.B.M., PERKINS S.J.  
Neutron and X-ray scattering studies on the human complement protein properdin provide an analysis of the thrombospondin repeat.  
Biochemistry **30**, 8000-8008 (1991).

**91RO1051**

ROBERTS M.A., FITCH A.N.

The crystal structures of  $\text{Ag}_4\text{Ge}_7\text{O}_{16}\cdot 6\text{D}_2\text{O}$  and  $\text{Na}_3(\text{ND}_4)\text{Ge}_7\text{O}_{16}\cdot 6\text{D}_2\text{O}$  refined from high resolution synchrotron radiation and neutron powder diffraction data. *Journal of Physics and Chemistry of Solids* **52**, 1209-1218 (1991).

**91ST1052**

STEYERL A.

Research using ultracold neutrons at the ILL. In "VI International School on Neutron Physics. Proceedings", held 8-18 October 1990 in Alushta, USSR, Vol. I pp. 250-260 (1991).

**91PE1053**

PERKINS S.J., NEALIS A.S., DUNHAM D.G., HARDINGHAM T.E., MUIR I.H.

Molecular modeling of the multidomain structures of the proteoglycan binding region and the link protein of cartilage by neutron and synchrotron X-ray scattering. *Biochemistry* **30**, 10708-10716 (1991).

**91DO1054**

DOSTER W.

The glass transition anomalies of myoglobin in the light of mode coupling theory. *Modern Physics Letters B* **5**, 1407-1414 (1991).

**91MI1055**

MIAO L., FOURCADE B., RAO M., WORTIS M., ZIA R.K.P.

Equilibrium budding and vesiculation in the curvature model of fluid lipid vesicles. *Physical Review A* **43**, 6843-6856 (1991).

**91CA1056**

CANNELLI G., CANTELLI R., CORDERO F., TREQUATTRINI F., ANDERSON I.S., RUSH J.J.

H tunneling and trapping in Y by anelastic relaxation measurements. *Physical Review Letters* **67**, 2682-2685 (1991).

**91HA1057**

HAYDEN S.M., AEPPLI G., OSBORN R., TAYLOR A.D., PERRING T.G., CHEONG S.W., FISK Z.

High-energy spin waves in  $\text{La}_2\text{CuO}_4$ . *Physical Review Letters* **67**, 3622-3625 (1991).

**91LI1058**

LIESER G., FISCHER E.W., IBEL K.

Conformation of polyethylene molecules in the melt as revealed by small-angle neutron scattering. *Polymer Letters Edition* **13**, 39-43 (1975).

**91PE1059**

PERKINS S.J., NEALIS A.S., SUTTON B.J., FEINSTEIN A.

Solution structure of human and mouse immunoglobulin M

by synchrotron x-ray scattering and molecular graphics modelling. A possible mechanism for complement activation.

*Journal of Molecular Biology* **221**, 1345-1366 (1991).

**91GU1060**

GUPTA S., MESSOLORAS S., SCHNEIDER J.R., STEWART R.J., ZULEHNER W.

Orientation of oxygen precipitates in silicon. *Semiconductor Science and Technology* **5**, 783-784 (1990).

**91GU1061**

GUPTA S., MESSOLORAS S., STEWART R.J., WILSON C.C., BROWN R.D., BRADBURY J.

Effects of spallation neutron irradiation on single crystals of iron, nickel, niobium and stainless steel. *Radiation Effects and Defects in Solids* **116**, 299-306 (1991).

**91GU1062**

GUPTA S., MESSOLORAS S., SCHNEIDER J.R., STEWART R.J., ZULEHNER W.

Oxygen precipitation in heavily boron-doped silicon. *Journal of Applied Crystallography* **24**, 576-580 (1991).

**91BO1063**

BOARDMAN C.J., KILCOYNE S.H., CYWINSKI R.

Recrystallization of  $\alpha\text{-Bi}_2\text{Sr}_2\text{CaCu}_2\text{O}_x$  studied using small angle neutron scattering. *Physica C* **185-189**, 633-634 (1991).

**91CH1064**

CHAILLOUT C., MARCUS J., MAREZIO M.

High temperature structure of  $\text{BaBiO}_3$  by single-crystal neutron diffraction. *Physica C* **185-189**, 2723-2724 (1991).

**91KA1065**

KALUS J., NEUBAUER G., SCHMELZER U.

A new shear apparatus for small angle neutron scattering (SANS) measurements. *Review of Scientific Instruments* **61**, 3384-3389 (1991).

**91HE1066**

HEMPELMANN R., RICHTER D.

Muons and neutrons. Complementary probes for hydrogen in metals. *Europhysics News* **22**, 110-114 (1991).

**91RI1067**

RICHTER D., HEMPELMANN R., SCHOENFELD C.

Study of the hydrogen jump geometry in an  $\alpha\text{-LaNi}_5\text{H}_x$  single crystal using quasi-elastic neutron scattering. *Journal of the Less-Common Metals* **172-174**, 595-602 (1991).

**91LA1068**

LARESE J.Z., HASTINGS J.M., PASSEL L., SMITH D., RICHTER D.

Rotational tunneling of methane on MgO surfaces :  
A neutron scattering study.  
Journal of Chemical Physics **95**, 6997-7000 (1991).

**91BO1069**

BOOTHROYD A.T., RENNIE A.R., BOOTHROYD C.B.

Direct measurement of the temperature dependence of the unperturbed dimensions of a polymer.  
Europhysics Letters **15**, 715-719 (1991).

**91WA1070**

WAGNER N.J., KRAUSE R., RENNIE A.R., D'AGUANNO B., GOODWIN J.

The microstructure of polydisperse, charged colloidal suspensions by light and neutron scattering.  
Journal of Chemical Physics **95**, 494-508 (1991).

**91FI1071**

FISCHER K.H.

Vortices in layered high- $T_c$  superconductors.  
Physica C **178**, 161-170 (1991).

**91LA1072**

LAMPARTER P., SCHAAL M., STEEB S.

Neutron- and X-ray-diffraction with amorphous Ni-Nb alloys.  
Institute of Physics Conference Series **101**, 51-66 (1990).

**91GE1073**

GELLETLY W.

Neutron capture in perspective.  
AIP Conference Proceedings **238**, 308-322 (1991).

**91BA1074**

BALODIS M.K., PROKOFJEV P.T., AFANASJEV A.V.

Experimental evidence for octupole deformation from observation of parity doublets in  $^{152}\text{Eu}$ ,  $^{154}\text{Eu}$ ,  $^{156}\text{Eu}$  neutron capture studies.  
AIP Conference Proceedings **238**, 446-454 (1991).

**91PE1075**

PERKINS S.J., NEALIS A.S., SIM R.B.

Oligomeric domain structure of human complement factor H by X-ray and neutron solution scattering.  
Biochemistry **30**, 2847-2857 (1991).

**91RO1076**

ROSSEINSKY M.J., PRASSIDES K., SCOTT C.A.

Magnetic phase diagram of the hole-doped  $T'$  phases  $\text{Nd}_{2-x}\text{Sr}_x\text{CuO}_{4-\delta}$   
Inorganic Chemistry **30**, 3367-3370 (1991).

**91DA1077**

DAVIDSON W.F., DIXON W.R.

Identification of rotational bands at intermediate excitation in  $^{168}\text{Er}$ .  
Journal of Physics G : Nuclear and Particle Physics **17**, 1683-1712 (1991).

**91OT1078**

OTTEWILL R.H.

The Rideal lecture. Colloidal dispersions.  
Faraday Discussions of the Chemical Society **90**, 1-15 (1990).

# AUTHOR INDEX

## Author Index

### Publications and Internal Reports 1991

ABELL J.S.	91FO500	ANDERSEN K.H.	91FA489	BAROCCHI F.	91MA269
ADAM G.W.	91JO139	ANDERSON I.S.	91BE366		91VE300
ADYA A.K.	91AD113		91AN426	BARRE S.	91BA442
AEBERSOLD M.A.	91AE243		91BO454	BARREAU G.	91KO475
AEPPLI G.	91HA117	ANDREJTSCHEFF W.	91CA1056		91BO491
	91CH305	ANDRES A. DE	91PE290	BARTHES M.	91BA129
	91HA407		91DE147	BARTSCH E.	91PE176
	291HA1057	ANDRES M.	91AN234		91DE236
AFANASJEV A.V.	91BA125	ANSALDO E.J.	91PR516	BARUCHEL J.	91BA157
	91BA1074	ANTSON O.	91PA343		91PE158
AGERON P.	91AG542	AOUIZERAT-ELARBY A.	91AN507		91BA221
	91AG544	APRAHAMIAN A.	91TR471		91PE330
AIME J.P.	91AI229	ARAPKOSKE S.K.	91DU144		91KU377
ALA-NISSILA T.	91AL424	ARMBRUSTER P.	91BO116		91KV419
	91AL425		91CA207		91SA537
ALAMI M.	91AL114		91SC179	BASHALL A.	91BA307
ALBA M.	91FA09T		91BE493	BASSEREAU P.	91BA391
	91TR187	ASGHAR M.	91AR556	BASTIDE J.	91ME389
	91HE188	ASMUSSEN B.	91BO491	BASTIE P.	91BE557
	91PE189	AUDIER M.	91PR296		91BE558
	91SO195		91BO102	BATALLAN F.	91BE161
	91JO230	AVIGNON M.	91GU119		91MA552
	91IV329	AXE J.D.	91JA160	BATESON R.D.	91BL237
	91SO355		91AU453		91BL238
ALBERDI J.M.	91CO298		91DU465		91BL240
	91CO341		91GA252		91LA457
ALBIGES-RIZO C.	91AL282		91AX26T	BATLLE X.	91OB186
ALBRECHT D.	91SC179	AXON S.A.	91GR169		91BA288
ALBRECHT T.	91AL295	BAADER H.A.	91WI357	BATTLE P.D.	91OB452
	91AL394	BABEL D.	91KO475		91BA536
ALDEBERT P.	91BA431	BAER G.	91NU386	BAUER E.	91BA1003
ALEFELD B.	91HE22G	BAFFIER N.	91LE429	BAUMANN J.	91GR548
ALEGRIA A.	91CO298	BAFILE U.	91BA431	BAUSENWEIN T.	91BA267
	91CO341		91VE115		91BA280
ALEKSEEV P.A.	91AL193	BAGLIN C.	91VE300	BAYERL T.M.	91BA363
ALLAN M.	91KU249	BAHNSEN A.	91NA264	BECKER G.	91JO139
	91MA250	BAKAS T.	91BU444	BECVAR F.	91BE126
ALLEN P.J.	91BE196	BAKER G.L.	91CO253	BEE M.	91BE12T
ALLENSPACH P.	91FU142	BALDO-CEOLIN M.	91AI229		91BE359
	91AL224	BALDWIN J.P.	91BI534		91JO1044
	91ST367		91WO194	BEHNIA K.	91CZ1045
	91AL432	BALL P.C.	91LA443	BEILLE J.	91TA554
	91FU462	BALLET O.	91SM1016	BELLET D.	91FE508
	91GU503	BALLOU R.	91CO253		91BE557
ALMAIRAC R.	91BA129	BALODIS M.K.	91BA124		91BE558
ALONSO J.	91AL01T		91BA388	BELLOUARD C.	91MI492
	91AL135	BALSEIRO C.A.	91BA125	BELTRAN A.	91AM342
	91OB186	BANASZAK L.	91BA1074	BELTRAN D.	91AM342
	91BE245		91GA252	BENETTI P.	91BI534
	91BE490	BANFI G.	91BA138	BENMOUNA M.	91DU202
	91AL551		91BA281	BENOIT A.	91BE418
	91AL553	BARAN E.J.	91DE435	BENOIT H.	91DU202
ALTEKAR W.	91EB358	BARANDIARAN J.M.	91BA561	BERGERSEN B.	91GI266
ALVAREZ F.	91CO341	BARBARA B.	91FE141		91HO293
ALVAREZ M.	91BE161	BARGE A.	91FE1046	BERK N.F.	91BE366
AMADOR J.	91AL135	BARHAM P.J.	91FE508		91AN426
AMOROS P.	91AM342	BARILO S.N.	91AL282	BERKOVITCH-YELLIN Z.	91E1390
		BARNES A.C.	91BA1002	BERMEJO F.J.	91BE161
		BARNES P.	91CH374		91MA205
		BARNES R.G.	91GA197		91MA235
			91BA1014		91BE245
			91AN426		91BE299
					91BE490

## AUTHOR INDEX

	91AL551	BOGDANOVIC M.	91KO475	BROKMEIER H.G.	91BR496
	91MA552	BOIREAU A.	91NU386	BROOKS M.S.S.	91LA242
	91AL553	BOISSIEU M. DE	91BO102		91BR1025
BERMEJO F.M.	91AL01T		91GU119		91LA1030
BERNAS M.	91BE493		91DO148	BROWN P.J.	91LA155
BERNHOEFT N.R.	91BE196		91JA151		91BR216
BERTAGNOLLI H.	91BA280		91JA160		91NE223
	91BA363		91JA200		91LA241
BERTHIER Y.	91PO545		91BO315		91LA242
BESNARD M.	91BE294		91BO324		91CH273
BEZOU C.	91BE438		91JA370		91BR318
BHATTARAI P.	91BH331		91AU453		91CH321
BIENFAIT M.	91LA314		91DU465		91NU328
	91VI468		91DO511		91CH374
BIERSACK J.P.	91FI1011		91PA564		91MA420
BITTER T.	91BI387		91BO566	BROWN R.D.	91GU1061
	91BI534	BOLLEN S.K.	91BA1003	BRUECKEL T.	91BR15T
BLANCO J.A.	91BL484	BONGIOVANNI R.	91BO303		91SO145
BLAND J.A.C.	91BL237	BONJOUR E.	91DI459		91GR169
	91BL238	BONNEAU P.	91BO173		91CH317
	91BL240	BONNET M.	91HO111		91MA436
	91BL254	BOOLCHAND P.	91KA251	BRUSETTI R.	91DI459
	91LA457	BOOTEN J.G.L.	91UL175	BRUSON A.	91VE13
BLANK H.	91FU142		91UL513		91SI398
	91BL150	BOOTHROYD A.T.	91RE1040	BUDTZ-JORGENSEN C.	91BU444
	91AL224		91BO1069		91OE445
	91AE243	BOOTHROYD C.B.	91BO1069	BUEHRER W.	91DE213
	91PR296	BORDET P.	91HE382	BUELOW M.	91JO1044
	91BL334	BORSALI R.	91DU202	BUNE A.V.	91VE217
	91ST367	BOSSY J.	91RO499		91BU433
	91AL432	BOTTO I.L.	91FE141	BURKEL E.	91DO456
	91FU462	BOUCHENEB N.	91BO491		91BU478
	91GU503	BOUCHER B.	91BO411	BURKHARDT E.	91SU497
BLASE W.	91BL541	BOUDARD M.	91BO324	BURLET P.	91RO121
BLUNDELL S.J.	91BL237		91DO511		91RO183
BOARDMAN C.J.	91BO1063		91BO566		91VE302
BOBISUT F.	91BI534	BOUE F.	91ME389		91CH317
BOCQUET J.P.	91BE493	BOUFFARD S.	91BA442		91CH321
BOENI P.	91BO101	BOUILLOT J.	91BA221		91RO464
	91BO163		91BO437		91RO499
	91BO454	BOURGAUX-LEONARD C.	91BO143	BUSCHMANN J.	91KO1049
BOERNER H.G.	91MA18T	BOURGES P.	91RO499	BUSSIERE A.	91NA264
	91BO116	BOURSON P.	91BO437	BUTERA R.	91BU177
	91UL175	BOUTELLIER R.	91SU497	BUZIER M.	91ME389
	91UL178	BOYLE C.M.	91EC105	CABANAS M.V.	91BA288
	91BO284	BOYSEN H.	91BO448	CABRINI D.	91DE1034
	91BO385	BRADBURY E.M.	91WO194	CADEVILLE M.C.	91PI166
	91UL455	BRADBURY J.	91GU1061	CAIGNAERT V.	91MI492
	91KO475	BRAMWELL S.	91CL344	CALDES M.T.	91CA362
	91KE494		91VI409		91CA502
	91UL513	BRANT S.	91MA549		91CA559
	91BO520	BRAUTMEIER D.	91BR346	CALEMCZUK R.	91DI459
	91JO521	BRAVIC G.	91KU249	CALLIGARICH E.	91BI534
	91KE522		91BR351	CALVARIN G.	91BO173
	91HO524	BRECHET Y.	91AU453		91MA353
	91UL525	BREITIG D.	91KO475	CANFIELD P.C.	91CH305
	91UL527	BRENTANO P.VON	91BO385	CANNELLI G.	91CA1056
	91RO529	BRIAT B.	91AE243	CANNON R.D.	91CA207
	91KL531	BRISSOT R.	91KO475		91CA301
	91WH532		91BE493	CANTELLI R.	91CA1056
	91MA549	BROCHIER A.	91FA09T	CANTU L.	91DE219
	91BO555	BROCHU R.	91AL114	CAPELLMANN H.	91NE223
BOETTCHER F.	91SI118				

## AUTHOR INDEX

CAPPELLETTI R.L.	91KA251		91BA280	COX S.F.J.	91CY311
CAPPONI J.J.	91CH16		91GA292	CRAWFORD R.J.	91CR1018
	91HE382		91BH331	CRESPI H.L.	91LE429
	91CH501		91BA363	CRICHTON R.R.	91KN336
CAREL C.	91GA349		91HA371	CROWLEY T.L.	91CR140
	91GA430		91BO411	CRUEGE F.	91SO355
CARLILE C.J.	91BE161		91RO439	CUBITT R.	91FO500
	91PR296		91DU479		91PA509
	91FI476		91HO547	CURRAT R.	91FA09T
CARLING S.G.	91VI401	CHIHARA H.	91IN1005		91BA129
CARMONA P.	91DU144	CHMAISSEN O.	91CH168		91CU153
CARO J.	91JO1044		91CH501		91DU185
CARRERA M.	91CA362	CHOW K.	91AN507		91CU458
CARY R.S.	91AN507	CHRISTENSEN A.N.	91FJ159	CUSACK S.	91DO274
CASAN-PASTOR N.	91FU354		91CH228	CUSSEN L.D.	91CO450
	91CA362		91BE438	CYROT M.	91FE508
	91AN507		91NO1038	CYWINSKI R.	91CY311
CASTEN R.F.	91BO116	CHROBOCZEK J.	91AL282		91RI405
	91BO385	CIZEWSKI J.A.	91BO520		91GA504
	91BO520	CLAMP M.E.	91CL344		91GA506
	91BO555	CLARKE S.M.	91MO1001		91BO1063
CASTETS C.	91CA04G		91CL1004	CZAJKOWSKI S.	91BE493
CATLOW C.R.A.	91CO1048		91IN1005	CZJZEK M.	91CZ285
CAUDRON R.	91RE1040	CLAUSEN K.N.	91MA297		91CZ384
CAULTON K.G.	91VA106		91CH305		91CZ1045
CAVATORTA F.	91DE1034	CLEZARDIN P.	91VU322	D'AGUANNO B.	91WA1070
CEBOLLADA A.	91MA239	COCKCROFT J.K.	91SI118	DARRIET J.	91LI498
	91MA481		91CO222	DASH J.G.	91GA268
	91BL238		91FI255	DAUDIN B.	91DA365
CELINSKI Z.	91RI488		91DO270		91MA510
CHABRE Y.	91BE299		91WE546	DAVID F.	91GU256
CHAHID A.	91CH168	CODDENS G.	91VI468	DAVIDSON W.F.	91BA125
CHAILLOUT C.	91HE382	COEY J.M.D.	91CO253		91DA1077
	91CH501		91DO417	DAY P.	91RO246
	91CH1064	COHEN-ADDAD C.	91SI428		91PR247
CHAMINADE J.P.	91RO539	COLE M.	91FI1024		91KU248
	91RO540	COLLIN G.	91SO145		91KU249
CHAN E.P.	91HO293	COLLINS D.R.	91CO1048		91MA250
CHARVOLIN J.	91SA152	COLMENERO J.	91CO298		91RO272
	91CH184		91CO341		91BR351
	91CH265	COLOMBET P.	91MU262		91VI401
CHASSEAU D.	91KU249	COLVIN G.	91BO385		91DA495
	91BR351		91WH532	DE GRAAF L.A.	91VE300
	91TR210	CONNELL J.G.	91MA549	DE GROOT P.A.J.	91GR505
CHATTOPADHYAY T.	91BR216	COOK J.C.	91CO421	DE KRUIF C.G.	91DU112
	91CH273		91CO06T		91DE381
	91CH317	COPNELL J.	91CO340		91DU402
	91CH321		91PE290	DEBUS O.	91DE236
	91CH374	COQUET E.	91RO523	DEGENHARDT D.	91VI468
	91MA420	CORBELIN S.	91BA221	DEGIORGIO V.	91DE219
CHEN D.	91OL310	CORDERO F.	91WE546		91DE435
CHENEVAS J.	91HE382	CORDIER G.	91CA1056	DELZENNE P.	91BA561
CHEONG S.W.	91CH305	CORTI M.	91BL541	DENNER L.	91BO143
	91HA407	COULOMBEAU C.	91DE219	DEPMEIER W.	91KO1049
	91HA1057	COUZI M.	91JO1031	DEPORTES J.	91DE213
	91RU170		91RO203		91BA124
CHEVRIER G.	91HE373		91RO539		91BR318
CHEVRIER J.	91DU144		91RO540		91VI401
CHIEUX P.	91MA171	COWLAM N.	91CO450	DERIU A.	91DE1034
	91GA197	COWLEY R.A.	91CO146	DERSCH D.	91LE429
	91CH198		91CO450	DESLATTES R.	91BO520
	91MA269	COX D.	91BE438		91KE522

# AUTHOR INDEX

DEWEY M.S.	91UL455	91JA200	91RI333
	91UL513	91BO324	91RI383
	91KE522	91DO415	91FA427
	91UL525	91AU453	91ME467
DEWEY S.M.	91BO520	91DU465	FARLEY T.W.D.
DIANOUX A.J.	91RO108	91DO511	FARNOUX B.
	91BA129	91BO566	FAUST H.R.
	91DU144	91BO102	
	91DI276	91VE136	
	91SA283	91DU112	
	91ST291	91DU402	
	91BE294	91PE1053	FAWLER J.F.
	91GU323	91DU1028	FEINSTEIN A.
	91BE359	91DU144	FENN R.H.
	91DI459	91DU479	FEREY G.
	91DU479	91DU185	
	91ST485	91BO437	
	91MI492	91DU202	
DICAPUA E.	91DI137	91EB358	
	91TI259	91HI360	FERNANDEZ BARQUIN L.
DIEHL R.M.	91FU132	91EC326	FERNANDEZ F.
DING J.	91DI372	91GA197	
DIVIS M.	91GR548	91EC105	
DIXON W.R.	91DA1077	91VA106	
DJURADO D.	91SA283	91KU422	
DOAN T.P.	91BO491	91RO540	FERNANDEZ-DIAZ M.T.
DOBSON M.	91DO17G	91ED313	
DOENNI A.	91DO270	91EF339	
DOLFINI R.	91BI534	91JO103	
DONG C.	91DO148	91BO385	
	91BO324	91MA473	
	91DO415	91KL531	
	91DU465	91MA549	
	91DO511	91KU422	
	91BO566	91EI1035	FERRER S.
DONNELLY K.	91DO417	91EI390	
DOPORTO M.	91PR247	91VA106	FETTERS L.J.
DORE J.C.	91CH198	91BI387	
	91HA371	91BI534	
DORNER B.	91DO16G	91BI387	
	91DO25	91BI534	FIGGIS B.N.
	91MA297	91AL394	FILHOL A.
	91VI325	91BE161	FILLAUX F.
	91VI410	91MA205	
	91DO456	91MA510	
	91DO460	91VE136	FILLION G.
	91BU478	91MA191	
DOSTER W.	91DO274	91DO16G	
	91DO1054	91BU177	FINEL A.
	91SI428	91EW277	FINK D.
DOUCE R.	91BO116	91RI278	
DRAAYER J.P.	91DU208	91RI333	
DUBBERS D.	91DU312	91FI1012	
	91DU361	91FA09T	
	91BI387	91SC379	FIONI G.
	91DU441	91FA489	FISCHER E.W.
	91BI534	91VE115	FISCHER J.E.
DUBOIS J.M.	91BO102	91PE176	
	91DO148	91BU177	FISCHER K.H.
	91JA151	91FR275	
	91JA160	91EW277	FISCHER P.
	91MA171	91RI278	
	DUBOST B.		91KR369
	DUFOUR C.		
	DUITS M.H.G.		
	DUNHAM D.G.		
	DUNSTETTER F.		
	DUPUY J.		
	DURAND D.		
	DUVAL M.		
	EBEL C.		
	EBEL T.		
	ECCLESTON R.S.		
	ECKERSLEY M.C.		
	ECKERT J.		
	ECKOLD G.		
	ECOLIVET C.		
	EDER K.		
	EFFENBERGER H.		
	EGIDY T.VON		
	EICHHORN G.		
	EICHHORN K.D.		
	EISENSTEIN M.		
	EISENSTEIN O.		
	EISERT F.		
	EL-MUZEINI P.		
	ELBEN H.		
	ENCISO E.		
	ERMOLIEFF A.		
	ERWIN R.		
	ESCHKOETTER P.		
	ESCHRIG H.		
	EWEN B.		
	FARAGO B.		
	FAHRNER W.		
	FAK B.		

## AUTHOR INDEX

FISHER R.A.	91FL122	FRUCHART D.	91DO417	GEISSLER E.	91HO192
FISK Z.	91HA117		91MI440		91MA233
	91NE22		91PO545	GELLETLY W.	91GE1073
	91CH305	FUCHS J.	91MA1022	GELTENBORT P.	91BO385
	91HA407	FUERTES A.	91AM342		91OE445
	91HA1057		91FU354		91BO491
FITCH A.N.	91CO222		91CA362	GENGER F.	91FO500
	91FI255		91CA502	GENONI M.	91BI534
	91WE546		91AN507	GEORGES R.	91LI498
	91FI1024		91CA559	GEWITZ H.S.	91EI390
	91GR1029	FUESS H.	91HO111	GEYER A. DE	91RO164
	91CO1048		91CZ285	GHORAYEB A.	91SO195
	91RO1051		91EF339	GHOSH R.E.	91GH07T
FJELLVAG H.	91FJ159		91CZ384		91GH308
	91NO1038	FUJARA F.	91FU132	GIBB T.C.	91BA1003
FLEISCHER T.	91LA395		91PE176	GIBBS D.	91GR169
FLOUQUET J.	91FL122		91DE236		91GI130
	91RE123	FURER N.	91RU170	GIBIN D.	91BI534
	91TA554	FURRER A.	91FU142	GIGLI BERZOLARI A.	91BI534
FOEHL K.	91HO524		91AL224	GIGNOUX D.	91GI404
FOERSTER I.	91BO385		91AE243		91BL484
FONTCUBERTA J.	91FU354		91DO270	GILL R.L.	91BO555
	91CA362		91ST367	GINGRAS M.J.P.	91GI266
	91PE380		91AL432		91HO293
FORD G.W.	91FO309		91FU462	GLEITER H.	91WA378
	91FO414	FYODOROV Y.V.	91GU503	GLEITZER C.	91MA226
	91FO434	GABRYS B.	91FY550	GLUECKLER H.	91AN507
	91FO480	GADE L.H.	91GA447	GOBERT G.	91GO28T
FORGAN E.M.	91FO500	GAEHLER R.	91BA307		91GO29T
	91PA509	GAGLIANO E.R.	91ED313		91GO30T
FORSYTH J.B.	91BR216	GALLEGO J.M.	91GA252	GOBRECHT K.	91BI387
	91NU328		91MA239		91BI534
FORT D.	91EC326		91MA481		91GO543
FOSTER N.D.	91FO10T	GARCIA A.	91CA362	GODFREY J.E.	91WO194
FOUASSIER M.	91SO195	GARCIA-HERNANDEZ M.	91AL01T	GODFRIN H.	91GO181
	91BE294		91BE161		91GO258
	91SO355		91MA205		91LA376
FOURCADE B.	91MI1055		91MA235		91MC393
FOURNIER T.	91CH168		91BE245		91LA466
	91CH501		91BE299	GOERLITZ D.	91FR469
FOWLER A.G.	91WO194		91BE490	GOLDBECK A.	91BO163
FRANK V.L.P.	91LA376		91AL551	GOLDBERG M.W.	91GO306
	91LA466		91MA552	GOLUB R.	91WO194
	91FR469		91AL553	GOMEZ SAL J.C.	91LA131
FRANSE J.J.M.	91NE223	GARCIA-MUNOZ J.L.	91GA316		91RO164
FRANZ H.	91MU347		91GA504		91FE1046
FREDRIKZE H.	91MA269		91GA506	GOMEZ-CUEVAS A.	91RO539
FREY F.	91BO448	GARNIER P.	91BO173	GOMEZ-ROMERO P.	91AM342
FRICK B.	91CO06T	GARRIN P.	91AI229		91FU354
	91FR275	GASKELL P.H.	91GA197		91CA502
	91CO298		91GA292		91AN507
	91CO341	GAUCKLER L.J.	91ST367	GOMPFF F.	91KA251
	91ST364	GAULTIER J.	91BR351	GONDRAND M.	91PE380
	91RI383	GAVARRI J.R.	91BO173	GONZALEZ-CALBET J.	91OB186
	91GR548		91GA349		91GA316
FRIDKIN V.M.	91VE217		91MA353		91CA362
	91BU433		91GA430		91CA559
FRIEND R.H.	91KU249	GAY J.M.	91GA268	GOODWIN J.	91WA1070
	91MA250		91VI468		91GO1013
FRIES T.	91ST180	GEIBEL A.	91WA378	GOPALAN P.	91LA155
		GEICK R.	91KU422		91LA241
				GOROCHOV O.	91SO195

## AUTHOR INDEX

GOUGEON P.	91DI459	HAYDEN S.M.	91HA117	HILLER H.	91JO103
GRAHAM R.G.	91BL240		91BE196		91MA473
GRANNEC J.	91RO540		91CH305		91KL531
GRASMEDER J.R.	91GR505		91HA407	HINGERTY B.E.	91DI372
GRATZ E.	91GR548		91TA554	HIRAI M.	91KN336
GRAVEREAU P.	91AL114		91HA1057	HLAWATSCH G.	91BO385
GREEN K.	91RI350	HAYES W.	91PR247	HOCK R.	91HO111
GREENE G.	91BO520		91FA271		91WI263
	91KE522	HAZELL R.G.	91CH228	HOCK S.	91MA297
GRIFFITHS A.R.	91EC326	HEAP R.T.	91HE1039	HODEAU J.L.	91HE382
GRIMES R.W.	91GR1029	HECHT A.M.	91HO192	HODGE D.J.	91HO206
GRIMM H.	91GR1041		91MA233	HOFF R.W.	91WH532
GROSS M.	91FI25T	HEGER G.	91RU170	HOFFMANN H.	91BA267
GRUBER M.	91ED313	HEIDEMANN A.	91CO06T		91MU304
GRUEBEL G.	91GI130		91HE22G		91KA332
	91GR169	HEIMING A.	91PE107		91MU345
	91SC379		91TR187	HOHLWEIN D.	91SO145
GUCKELSBERGER K.	91RU170		91HE188		91ST180
GUEDEL H.U.	91AE243		91PE189	HOLDSWORTH P.C.W.	91GI266
	91DO270	HEINRICH B.	91HE373		91HO293
	91KR369	HELLMANN E.H.	91BL238	HONIG G.	91LA155
	91BI534		91HE174		91LA241
GUGLIELMI A.	91KU377	HELLMANN G.P.	91HE227	HOPPE R.	91LA395
GUIGAY J.P.	91NA264		91HE174	HORKAY F.	91HO192
GUILLAUD J.P.	91GU323	HEMPELMANN R.	91HE227		91MA233
GUILLAUME F.	91GU503		91ST291	HOSER A.	91ST180
GUILLAUME M.	91MI440		91CO340		91MA1022
GUILLOT M.	91GU256		91ST485	HOUSSAINI S.	91VE136
GUITTER E.	91GU1060		91HE517	HOWE M.A.	91MC1023
GUPTA S.	91GU1061	HENNION M.	91HE1066	HOWELL I.	91HO547
	91GU1062	HENRY J.Y.	91RI1067	HOWELLS W.S.	91BE161
	91KO128		91MI492		91BE245
GURU ROW T.N.	91BA125		91RO183		91AL551
GUSEVA T.V.	91FE1046	HERDMAN G.J.	91VE302		91AL553
GUTIERREZ J.	91GU119	HERNANDEZ E.	91RO464	HOYLER F.	91BO385
GUYOT P.	91AU453	HERR U.	91RO499		91HO524
	91KO1049	HERZIG C.	91BO454		91JO528
HAARICH M.	91FL122		91AM342		91WH532
HAEN P.	91BA431		91MU347	HUANG J.S.	91BU177
HAESSLIN H.W.	91AL114		91PE107		91EW277
HAGENMULLER P.	91NU386	HEUMANN H.	91TR187		91RI278
HAHN F.	91KA251	HEURTEAUX C.	91HE188		91RI333
HALFPAP B.	91EC105	HEWAT A.W.	91PE189	HUANG T.C.	91FA427
HALL J.H.	91VA106		91LE429	HUFFMAN J.C.	91LA172
	91HA371		91HE1033	HULL S.	91VA106
HALLBRUCKER A.	91HA211		91AX26T	HUNDLEY M.F.	91FA271
HANLEY H.J.M.	91PE1053		91IH109	HUSSON E.	91HA117
HARDINGHAM T.E.	91VI408		91KO128		91BO173
HARRISON A.	91VI410		91KO156		91MA353
	91GI130		91BO173	HUTCHINGS M.T.	91FA271
HARSHMAN D.R.	91TA554		91CH228	IAYDJIEV P.	91RI350
HASSELBACH K.	91LA1068		91HE279	IBANEZ R.	91AM342
HASTINGS J.M.	91BO454		91GA349	IBARRA M.R.	91IB451
HAUERT R.	91TI212		91MA353	IBEL K.	91MA191
HAUK J.	91BE126	HEWAT E.A.	91KR369		91WO194
HAUSEN H.D.	91RU170		91HE382		91MU304
HAUSSUEHL S.	91EC105	HEYDE K.	91HE463		91GO306
HAY P.J.		HILFRICH K.	91HE565		91KA332
			91HE382		91MU345
			91TR471		91LA443
			91JO518		91LI1058
			91HI360	IHRINGER J.	91IH109

# AUTHOR INDEX

IJJAALI M.	91MA226	JOLIE J.	91MA18T	KIEBEL M.	91PE176
ILL	91IL03T		91JO103		91DE236
	91IL19T		91BO116	KILCOYNE S.H.	91CY311
ILLINI T.	91BU478		91UL178		91RI405
IMAI B.S.	91WO194		91BO284		91GA504
INABA A.	91IN1005		91UL455		91GA506
ISAACS E.D.	91GI130		91KE494		91BO1063
ISNARD O.	91MI440		91UL513	KILNER J.	91LA443
IVANOV A.S.	91IV329		91JO518	KILVINGTON A.I.	91RI350
IVISON P.K.	91CO450		91JO519	KIM H.J.	91FI104
JACCARD D.	91FL122		91BO520	KIMMIG M.	91AL394
JACKSON S.A.	91VA106		91JO521	KING S.M.	91SC319
JACOUD J.L.	91RE123		91RO523	KINGSBURY D.L.	91VI468
JAEGER R.	91JA31T		91UL525	KINKEL U.	91BI387
	91AL295		91JO528		91BI534
	91AL394		91RO529	KITAKA S.	91MO1001
JAHNEL F.	91FI1011		91MA549	KJOLL J.	91AL424
JAL J.F.	91DU144		91BO555		91AL425
	91DU479	JONASSON P.	91BU444	KLATT M.	91BR496
JANIK J.A.	91BE359	JONES C.W.	91BA536	KLEMT E.	91BI387
JANIK J.M.	91BE359	JONES D.L.	91JO230		91BI534
JANNSEN T.	91PR247	JONES K.	91JU05T	KLINOWSKI J.	91WI357
JANOT C.	91BO102	JOUBERT J.C.	91PE380	KLORA J.	91JO103
	91MA120	JUDGE S.M.	91JU02T		91MA473
	91DO148		91JU05T		91KL531
	91JA151		91RO529	KNOECHEL A.	91KO1049
	91JA160		91KL531	KNOP W.	91KN336
	91RO164	KAERGER J.	91MA549		91KN348
	91JA200	KAKURAI K.	91JO1044		91KN461
	91JA214	KALDIS E.	91MA297	KOCH M.H.J.	91WO194
	91BO315		91FU142	KOCH R.	91KO475
	91BO324		91AL224	KOEBLER U.	91CH273
	91JA370		91AL432	KOETZLE T.F.	91VA106
	91AU453		91FU462	KOETZLER J.	91BO163
	91DU465	KALUS J.	91BA267	KOLBECK C.	91MI440
	91DO511		91MU304	KOLLMAR A.	91KO1042
	91JA562		91KA332	KONDUROV I.A.	91KO475
	91JA563		91MU345	KORITSANSZKY T.	91KO1049
	91PA564		91KA1006	KOSSAKOWSKI R.	91NA264
	91BO566	KAMITAKAHARA W.A.	91KA1065	KOTUNOV V.V.	91AL193
	91JA416	KANAZAWA D.	91KA251	KOVATCHEVA D.	91KO128
JANSSEN D.	91JA399	KANE W.R.	91KU248		91KO156
JANSSEN T.	91JA400	KARPINSKI J.	91BO385	KRAEMER K.	91KR369
	91CA207		91FU142	KRAMER N.D.	91BA125
JAYASOORIYA U.A.	91CA301		91AL224	KRAUSE R.	91WA1070
	91CO146		91AL432	KREMER R.K.	91VI409
JEHAN D.A.	91MC393		91FU462	KRISHNAN G.	91EB358
	91MI492	KEARLEY G.J.	91RO108	KRUMPOLC M.	91KN336
JEHANNO G.	91MC1008		91PR165		91KN461
JENSEN J.	91JO1031		91FI225	KRUSCHE B.	91BO116
JOBIC H.	91JO1044		91BL334		91UL175
	91CZ1045		91TO335		91BO520
JOHANSSON B.	91BR1025	KEINONEN J.	91WI357		91HO524
	91LA1030	KEMMLER-SACK S.	91FI476		91JO528
JOHNSON A.D.	91BL237	KERR S.	91KE494		91KL531
	91BL238	KESSLER E.G.	91ST180		91KR533
	91BL254		91KO475		91KR535
	91LA457		91KE494		91MA549
JOHNSON B.F.G.	91BA307	KESSLER M.	91BO520	KRUTOV G.	91TR471
JOHNSON S.J.	91JO139		91KE522	KUBAS G.J.	91EC105
			91BI387		91VA106
			91BI534	KUCHARSKI E.S.	91RE449

## AUTHOR INDEX

KUHS W.F.	91RO1020		91LA470		91SC319
	91MC1036	LAUTIE A.	91FI225		91KA332
KULDA J.	91KU377	LAVAGNA M.	91LA320		91BR346
	91KU486	LAVEDER M.	91BI534		91ME389
KULLMANN W.	91KU422	LAYET J.M.	91LA314	LIPOWSKY R.	91WU512
KURBAKOV A.	91TR471	LAZUKOV V.N.	91AL193	LIPPERT W.	91BI387
	91GU503	LE FLEM G.	91AL114		91BI534
KURMOO M.	91PR247	LEBECHE B.	91LA242	LIRZIN A. LE	91LI498
	91KU248		91LE1026	LISS K.D.	91LI289
	91KU249	LEBERMAN R.	91PA215	LITVINSKY L.L.	91KL531
	91MA250	LEBLANC M.	91LE133	LITZLER A.	91BA442
	91BR351		91LA134	LIU F.C.	91VI468
KURONEN A.	91KE494		91LA403	LIVAGE J.	91BA431
KUSCHKE W.M.	91KU1032	LECHNER M.D.	91GO306	LOEWENHAUPT M.	91TR210
	91KU1047	LEDERER H.	91LE429		91GR548
KVARDAKOV V.V.	91KV419	LEE E.M.	91CR140	LOIDL A.	91SC412
LACORRE P.	91LE133	LEE S.L.	91FO500	LONZARICH G.G.	91BE196
	91LA134		91PA509	LOTZ B.	91WI218
	91LA154	LEGRAND J.F.	91BO143	LUCAZEAU G.	91RO108
	91LA172		91DU185	LUETHI B.	91TH356
	91LA395		91VE217	LUGER P.	91KO1049
	91LA403		91WI218	LYON O.	91SI398
LACROIX C.	91BA388		91DA365	MA J.	91VI468
LAMBERT M.	91DU185		91BU433	MA Y.	91MA120
LAMBERT S.	91LA443	LEHMANN M.S.	91MA510	MAC MAHON T.D.	91KO475
	91WO194		91BE438	MACCHI F.	91DA365
LAMOREAUX S.K.	91LA131		91WI446		91MA510
LAMPARTER P.	91KU1032	LEIBLER S.	91GU256	MADSEN M.M.	91BU444
	91KU1047	LEIDERER P.	91LA376	MAGERL A.	91FI104
	91LA1072		91LA466		91LI289
LANDER G.H.	91LA155		91FR469		91ST291
	91GR169	LEJAY P.	91FL122		91AN426
	91JO230		91RE123		91ST485
	91LA241	LEMAIRE R.	91BA124	MAGGS A.C.	91GU256
	91LA242	LEROUX B.	91BO491	MAGID L.J.	91SC319
	91MA436	LEWIS J.	91BA307	MAGLI R.	91MA269
	91LA1007		91FO480	MAHJOUR A.R.	91MA1022
	91BR1025	LI J.C.	91TU199	MAICHLE J.K.	91IH109
	91LE1026	LI X.-O.	91MA120	MAIER J.	91AX26T
	91LA1030	LIAUD P.	91NA264	MALAMAN B.	91MA226
LAPERTOT G.	91RO183	LIBMAN V.A.	91KL531	MALETTA H.	91MA420
	91VE302	LIEB K.P.	91UL175	MALLAM S.	91HO192
	91RO464		91UL178		91MA233
	91RO499		91MI413	MALUGANI J.P.	91DI276
LARESE J.Z.	91LA1068		91UL455		91RO439
LARTIGUE C.	91DU202		91UL513	MAMPE W.	91DU312
	91ME467		91BO520		91ED313
LASSEGUES J.C.	91BE294		91UL525		91RI350
LAST J.	91LA149		91MI526	MANGIN P.	91VE136
LAUGHLIN R.G.	91HO206	LIEBERZ D.	91UL527		91RO244
LAUTENSCHLAEGER G.	91WI263	LIESER G.	91BO385		91CO253
LAUTER H.J.	91GO181	LINDGARD P.A.	91LI1058	MANIVANNAN V.	91KO128
	91BL237	LINDNER H.	91MA297	MARCHAL G.	91VE136
	91BL238		91JO103	MARCUS J.	91CH1064
	91BL240		91BO385	MARET M.	91MA171
	91BL254		91MA473	MAREZIO M.	91CH168
	91GA268		91KL531		91HE382
	91LA376	LINDNER P.	91LI209		91CH501
	91LA457		91HA211		91CH1064
	91LA466		91BA267	MARGACA F.M.A	91AX26T
	91VI468		91LI287	MARIGNAN J.	91BA391
	91FR469		91OL310		

## AUTHOR INDEX

MARMEGGI J.C.	91GR169	MAYER E.	91HA371	MIRAGLIA S.	91DO417
	91MA436	MAYER H.M.	91MA297		91MI440
	91MA538	MAYERHOFER U.	91MA18T	MIRANDA R.	91MA239
MARQUINA C.	91IB451		91MA20T		91MA481
MARSDEN I.R.	91MA250		91JO103	MIRAVITLLES C.	91FU354
MARTAN J.	91FI1012		91MA473		91CA362
MARTHON S.	91MA510		91KL531		91CA559
MARTIN D.	91MA205		91MA549	MIREBEAU I.	91MI492
	91BE245	MCCAUSLAND M.A.H.	91RE1040	MIRMELSTEIN A.	91FU142
MARTIN-MARERO D.	91BE299	MCDERMOTT D.C.	91JO139		91FU462
	91BE490	MCEWEN K.A.	91MC1008	MITCHELL P.W.	91RE327
	91MA552	MCGREEVY R.L.	91MC1023		91CL344
MARTINEZ B.	91FU354	MCINTYRE G.J.	91CO146		91HE1039
	91OB452		91CH168		91RE1040
	91AN507		91BA307	MITROFANOV N.L.	91IV329
MARTINEZ J.L.	91AL01T		91EC326	MITSUNARI T.	91KO475
	91BO101		91VI408	MOLINIE P.	91MU262
	91FE110		91CH501	MOMPEAN F.J.	91BE161
	91FE141	MCKENZIE D.R.	91GA292		91MA205
	91DE147	MCMAHON M.I.	91MC1036		91MA235
	91BO163		91PI1037		91BE245
	91OB186	MCMORROW D.F.	91CO146		91BE299
	91MA204		91MC393		91BE490
	91MA205		91RE327		91MA552
	91SA231	MCPARTLIN M.	91BA307	MONNEREAU O.	91GA349
	91RO232	MCPHAIL M.	91BO385		91GA430
	91AN234	MCWHAN D.B.	91GI130	MOOK H.A.	91HA117
	91MA235	MEDARDE M.	91PR516		91CH305
	91MA239	MEERWINCK W.	91KN336		91HA407
	91BE245		91KN348		91FO500
	91BE299	MEIENBURG W.	91BI387		91PA509
	91CH305	MENDES E.	91ME389	MOORE A.W.	91FI104
	91CO450	MENOVSKY A.	91NE223	MOORJANI K.	91MI492
	91OB452	MERCIER R.	91DI276	MORELL A.	91BO173
	91MA474		91RO439		91MA353
	91MA481	MESOT J.	91FU142	MORENO M.	91RO164
	91BE490		91AL224	MORET J.	91BA129
	91FE508		91ST367	MORIN P.	91FL122
	91PR516		91AL432	MORISHIGE K.	91MO1001
	91AL551		91FU462	MORTENSEN K.	91LE429
	91MA552		91GU503	MOUDRIANAKIS E.N.	91WO194
	91AL553	MESSOLORAS S.	91GU1060	MUELLER G.	91EF339
MARUYAMA M.	91VI468		91GU1061	MUELLER H.	91GR548
MASON S.A.	91ST261		91GU1062	MUELLER R.	91ST367
	91DI372	MEYER G.	91KR369	MUELLER-STACH M.	91MU347
	91RE449	MEZEI F.	91VE115		91FI1009
	91CH305		91DU185		91FI1012
MASON T.E.	91NU386		91ME467		91MU1021
MASSA W.	91MA353	MEZZETTO M.	91BI534	MUENCH C.	91MU304
MATHAN N. DE	91BA1003	MIAO L.	91MI1055		91KA332
MATSUO M.	91LA242	MICHAELSEN S.	91MI413		91MU345
MATTENBERGER K.	91BI534		91MI526	MUIR I.H.	91PE1053
MATTIOLI F.	91MA191	MIDDENDORF H.D.	91DE1034	MUNDT O.	91BE126
MATULL R.	91TR471	MIEKELEY W.	91TR187	MURANI A.P.	91RE327
MATVEEV A.	91BI534	MIGNOT J.M.	91RE123		91GI404
MAURI F.	91DU112	MIGUEL J.J. DE	91MA239	MURZIN A.V.	91KL531
MAY R.P.	91WO194		91MA481	MUTKA H.	91FU142
	91MA286	MILLER A.	91VU322		91AL224
	91DE381	MILLIKEN J.W.	91FI104		91KA251
	91BA391	MILLS D.	91GI130		91MU262
	91DU402	MILLS O.S.	91CL344		91VE300
	91LE429	MILNER S.T.	91FA427		91ST367

## AUTHOR INDEX

	91AL432		91FU354	PAVLOVIC A.S.	91IB451
	91BA442		91CA362	PAYEN C.	91MU262
	91FU462		91OB452	PEARCE A.	91PE158
	91GU503		91GA504		91PE330
MUYLDERMANS S.	91LA443		91GA506	PEBAY-PEYROULA E.	91EI390
NASTOLL H.	91NA264		91AN507	PEIFFER D.G.	91GA447
NATTERMANN T.	91FI201		91CA559	PEISL J.	91MU347
NAVARRO J.M.	91FU354	OCAL C.	91MA239		91BU478
	91CA362		91MA481	PENDLEBURY J.M.	91LA131
	91AN507	ODIER P.	91MA204		91RI350
	91CA559		91OB452		91PE477
NAZZAL A.I.	91LA172		91FE508		91PE487
NEALIS A.S.	91PE1053	OED A.	91BU444	PENFOLD J.	91CR140
	91PE1059		91OE445		91BL237
	91PE1075		91BO491		91BL240
NEILSON G.W.	91AD113	OLAH G.	91KN333		91BO454
	91NE167		91KN348	PEREZ F.	91FU354
	91HO547	OLBRICH E.	91OL310		91CA362
NELMES R.J.	91MC1036	OLESEN C.	91BU444		91AN507
	91PI1037	ORLOV V.G.	91AL193	PERKINS S.J.	91SM1050
NEMBACH E.	91HI360	OSBORN R.	91HE103		91PE1053
NEUBAUER G.	91MU304		91HA1057		91PE1059
	91MU345	OSHEROFF D.D.	91GO258		91PE1075
	91KA1065	OSTANEVICH Y.M.	91PA215	PERNET M.	91BA288
NEUBURGER M.	91SI428	OTTEWILL R.H.	91HO206		91PE380
NEUMAIER K.	91ST291		91BO303	PERRING T.G.	91HA1057
	91ST485		91GO1013	PETKOV P.	91PE290
NEUMANN D.A.	91KA251		91OT1043	PETRY W.	91CO06T
NEUMANN K.U.	91NE223		91OT1078		91PE107
NIEDERMAYER C.	91AN507	OUZNADJI H.	91HE1033		91FU132
NIELSEN M.	91NO1038	OUZNADJI S.	91HE1033		91PE176
NIEMINEN R.M.	91KE494	PAAR V.	91MA549		91TR187
NIERHAUS K.H.	91KN461	PALACIO F.	91PA343		91HE188
	91KN336	PALMER S.B.	91BA157		91PE189
	91KN348		91PE158		91DE236
NIINIKOSKI T.O.	91KN336		91EC326		91PE260
	91KN348		91PE330		91DO274
	91KN461	PANNETIER J.	91PA21T		91BE294
NOAKES D.R.	91AN507		91PA27T		91AL295
NOLAN K.F.	91SM1050		91LE133		91MU347
NONAT A.	91BE438		91LA134		91HI360
NORBY P.	91NO1038		91LA154		91HE373
NORDMEIER E.	91GO306		91FJ159		91WA378
NORRIS C.	91BL254		91WE162	PFEIFER H.	91JO1044
NORTON M.L.	91PA509		91LA172	PHILLIPS N.E.	91FL122
NOWOTNY H.	91GR548		91PA343	PHILLIPS T.E.	91MI492
NOZIERES P.	91NO375		91LA395	PIAZZA R.	91DE219
	91NO560		91LA403	PIAZZOLI A.	91BI534
	91NU386		91RI488	PICOT C.	91DU202
NUNEZ P.	91BA388	PAPOULAR R.	91DU185	PIEPENBRING R.	91BO116
NUNEZ REGUEIRO M.D.	91BR216		91BO315	PIERRON-BOHNES V.	91PI166
NUNEZ V.	91NU328		91PA564	PILLMAYR N.	91GR548
	91FO309	PARRAS M.	91GA316	PILTZ R.O.	91PI1037
O'CONNELL R.F.	91FO414	PASSEL L.	91LA1068	PINSTON J.A.	91BA125
	91FO434	PASTUREL A.	91MA171	PLAKHTY V.	91DU1028
	91FO480	PATTERSON C.	91MC393	PODSIADLY R.	91BE359
O'MARD L.P.	91HA371		91CO450	PODURETS K.M.	91KV419
O'REILLY K.P.J.	91CH228	PATZ M.	91KO1049	POINSIGNON C.	91RI488
OBERTELLI S.D.	91MA250	PAUL D.MCK.	91BE196	POLIKS B.J.	91BA138
OBRADORS X.	91OB186		91FO500	PONTONNIER L.	91PO545
	91BA288		91PA509	PORTE G.	91BA391
	91GA316	PAVLOV M.Y.	91PA215	POTEL M.	91DI459

# AUTHOR INDEX

PRAGER M.	91PR296		91DE435	ROBL C.	91RO1020
PRAKASH O.	91RE327		91BA561	RODEWALD W.	91MA297
PRANDL W.	91IH109		91BO1069	RODMACQ B.	91RO244
PRASSIDES K.	91RO246		91WA1070	RODRIGUEZ F.	91RO164
	91RO272	REYNOLDS P.A.	91RE449	RODRIGUEZ FERNANDEZ J.	91FE1046
	91RO1076	RHYNE J.J.	91VE136	RODRIGUEZ V.	91RO203
PRATT F.L.	91PR247	RICHARDS R.W.	91CO421		91SU497
PRESS W.	91PR296	RICHARDSON D.J.	91RI350		91RO539
PRICE D.L.	91PR165	RICHTER D.	91BU177		91RO540
	91HE517		91FR27	RODRIGUEZ-CARVAJAL J.	91FE110
PRIETO C.	91PR516		91EW277		91FE141
PROKOFJEV P.T.	91BA125		91RI278		91DE147
	91BA1074		91ST291		91OB186
PUGLIERIN G.	91BI534		91RI333		91MA204
PUJOL S.	91BE418		91CO340		91SA231
PUSKA M.J.	91KE494		91RI383		91RO232
PYCKHOUT-HINTZEN W.	91BU177		91AN426		91AN234
RAINFORD B.D.	91SA423		91FA427		91BA288
	91GR505		91ST485		91GA316
	91RE1040		91HE517		91AM342
RAMAKRISHNAN S.	91AI229		91HE1066		91PA343
RAMMAL R.	91SH392		91RI1067		91FU354
RAMSEY N.F.	91RA1015	RIECK C.T.	91LA1068		91CA362
RANGAVITTAL N.	91KO128	RIEDI P.C.	91RI368		91PE380
RAO C.N.R.	91KO128	RIEUTORD F.	91BL240		91OB452
RAO M.	91MI1055		91LA314		91CA502
RAPP R.E.	91GO181		91SI398		91GA506
	91GO258	RIGHINI G.	91VI468		91AN507
RAPPOLDI A.	91BI534		91DE435		91FE508
RASELLI G.L.	91BI534	RIJLLART A.	91BA561		91PR516
RASINES I.	91AL135		91KN336	ROSS D.K.	91CA559
RAUCH H.	91AX26T		91KN348		91TU199
RAUH H.	91KU422	RIPERT M.	91KN461		91CO340
RAVEY J.C.	91RA1019	RIPOLL C.	91RI488	ROSSAT-MIGNOD J.	91RO121
REBIZANT J.	91JO230	RISEMAM T.M.	91HE1033		91RE123
REBOUILLAT J.P.	91MA239	RITTER C.	91AN507		91RO183
REGNAULT L.P.	91RO121		91AL394		91VE302
	91RE123		91RI405		91RO464
	91RO183	ROBERTS M.A.	91IB451		91RO499
	91VE302	ROBERTS M.P.	91BR496	ROSSEINSKY M.J.	91RO246
	91RO464	ROBINSON S.J.	91RO1051		91MA250
	91RO499		91RO108		91RO272
REID B.L.	91RE327		91BO116		91BR351
	91RE1040		91UL175		91RO1076
REID K.B.M.	91SM1050		91UL178	ROTH M.	91EI390
REIJERS R.	91PR165		91PE290	ROUAULT P.	91BA124
REITER G.	91HE517		91BO385	ROUCAU C.	91BA442
RENAULT A.	91BO143		91MI413	ROUSSELOT C.	91RO439
RENNIE A.R.	91JO139		91UL455	RUBLEVSKAYA I.N.	91PA215
	91CR140		91UL513	RUEDLINGER M.	91RU170
	91HE174		91BO520	RUIGROK R.W.H.	91DI137
	91HO192		91JO521		91TI259
	91HO206		91RO523		91AL282
	91DE219		91HO524	RULLIER-ALBENQUE F.	91BA442
	91HE227		91UL525	RUMIANTSEV A.Y.	91IV329
	91MA233		91MI526	RUPP R.A.	91MA191
	91BO303		91UL527	RUPPRECHT A.	91GR1041
	91GH308		91RO529	RUSH J.J.	91BE366
	91CO421		91RO530		91AN426
			91KL531		91CA1056
			91MA549		
			91BO555		

## AUTHOR INDEX

RUSIECKI S.	91FU142	SCHMELZER U.	91MU304	SIM R.B.	91PE1075
	91AL224		91KA332	SIMIC J.	91KO475
	91AL432		91MU345	SIMISTER E.A.	91CR140
	91FU462		91KA1065	SIMON A.	91SI118
RUTERANA P.	91BO454	SCHMID H.	91SU497	SIMON J.P.	91SI398
RYTZ D.	91HA117	SCHMITT D.	91GI404	SINGLETON J.	91PR247
	91HA407		91BL484	SMALLEY M.V.	91SM1016
SABOUNGI M.L.	91PR165	SCHNAUSS W.	91FU132		91SM1017
SACKMANN E.	91JO139	SCHNECK J.	91BA442		91CR1018
SADIKOV I.P.	91AL193	SCHNEIDER J.R.	91LI289	SMITH D.	91LA1068
SADLER D.M.	91BA1002		91GU1060	SMITH J.L.	91NE223
SADOC J.F.	91SA152	SCHNOPPER H.W.	91GU1062	SMITH K.F.	91SM1050
	91CH265	SCHOBER H.R.	91BU444	SOLT K.	91BO454
SAEED A.	91GA292		91TR187	SONNTAG R.	91SO145
SAENGER W.	91ST261		91HE188		91ST180
	91DI372		91PE189		
SAEZ-PUCHE R.	91FE110		91HE373	SOUBEYROUX J.L.	91AL114
	91FE141		91ST515		91BA124
	91DE147	SCHOENFELD C.	91RI1067		91AL135
	91SA231	SCHOPHOL N.	91SC182		91MA226
	91AN234		91RI368		91MU262
	91PR516	SCHRAEDER T.	91SC412		91NU386
	91FA427	SCHRECKENBACH K.	91MA18T		91DO417
SAFRAN S.A.	91SA231		91BA125		91BO437
SALINAS-SANCHEZ A.	91KA332		91NA264		91MI440
SANDER J.	91KV419		91KO475		91LI498
SANDONIS J.	91SA537		91WH532		91RO540
	91JO1031	SCHUCK P.	91MA549		91PO545
SANTINI C.C.	91SA127	SCHULTZ L.	91JA416	SOULETIE B.	91KO156
SARKISSIAN B.V.B.	91TU199	SCHURTENBERGER P.	91KU1032	SOURISSEAU C.	91SO195
	91SA423	SCHWARZ W.	91SC319		91RO203
SAUVAJOL J.L.	91BA129	SCHWEISS P.	91BE126		91GU323
	91SA283	SCHWEIZER J.	91RU170		91SO355
	91BI534		91FL122		91RO540
SCANNICCHIO D.	91IL23G	SCHWEIZER T.	91DU1028	SOUSA J.B.	91PE158
SCAPRO	91LA1072	SCHWICKERT H.	91ST367	SPALEK J.	91LA155
SCHAAL M.	91PI166	SCIAU P.	91AL394		91LA241
SCHAERPF O.	91CY311	SCONZA A.	91SU497	SPIRLET J.C.	91JO230
	91KN336	SCOTT C.A.	91BI534	SPITS A.M.J.	91BA125
	91SC338		91CY311	SPOHR R.	91SC179
	91KN348	SEEGER A.	91RO1076	STAMM M.	91BR346
	91HI360	SEITSONEN A.P.	91KO1042	STASSIS C.	91LA155
	91HE373	SELBACH J.	91KE494		91LA241
	91GA447		91MU304	STAUB U.	91FU142
	91BO454	SEMMINGSSEN D.	91KA332		91AL224
	91KN461	SEPPELT K.	91MC1036		91ST367
	91GR505	SERDYUK I.N.	91MA1022		91AL432
	91GA506	SEYFARTH H.	91PA215		91FU462
SCHALT W.	91KO1042	SHACKLETON C.	91KO475		91GU503
SCHARNBERG K.	91RI368		91BL237	STEBE M.J.	91RA1019
SCHAUPERT K.	91SC179	SHARON R.	91BL240	STEEB S.	91KU1032
SCHEFER J.	91RU170	SHARROCK W.	91EI390		91KU1047
SCHERM R.	91SC379	SHENDER E.F.	91BA281		91LA1072
SCHILLEBEECKX P.	91UL178		91SH392	STEIGENBERGER U.	91KU422
	91HO524	SHILSTEIN S.S.	91FY550		91MC1008
	91RO529	SICRE A.	91KV419	STEINBINDER D.	91ST291
SCHINK H.J.	91KN336	SIEGEL J.	91BO491		91ST485
	91KN348	SIEKER L.	91FI1012	STEINER M.	91MA297
SCHLENKER M.	91BA157	SILLESU H.	91SI428		91VI325
	91KU377		91FU132		91DO460
			91PE176	STEINER R.	91AL295
			91DE236		91AL394

## AUTHOR INDEX

STEINER T.	91ST261	THIERFELDT S.	91TR210	VALLET-REGI M.	91GA316
	91DI372	THOMAS R.K.	91JO139		91CA362
STEINER W.	91GR548		91CR140	VAN ASSCHE P.H.M.	91BA125
STEPANOV A.A.	91CH374		91MO1001	VAN DER SLUYS L.S.	91VA106
STERN E.A.	91MA120		91CL1004	VASCON M.	91BI534
STEWART R.J.	91GU1060		91IN1005	VENTURINI G.	91MA226
	91GU1061	THUNIG C.	91CR1018	VERGAMINI P.J.	91VA106
	91GU1062	THYSSEN H.	91BA267	VERGNAT M.	91VE136
STEYERL A.	91ST1052	TIKKANEN P.	91KO1042	VERKERK P.	91VE115
STIRLING W.G.	91JO230	TIMMINS P.A.	91KE494		91VE300
STRATY G.C.	91HA211		91DI137	VERKHOVSKAYA K.A.	91VE217
STRAUCH D.	91DO257		91BA138	VETTIER C.	91RO121
STRIDE J.A.	91ST13T		91BE196		91FL122
STROBEL P.	91KO156		91TI212		91RE123
	91PE380		91AI229		91GI130
STROBL G.	91AL295		91TI259		91VE136
	91AL394		91BA281		91FU142
STRONACH C.E.	91AN507		91AL282		91RO183
STUDER F.	91BA536		91FO500		91AL224
STUEHN B.	91AL295		91PA509		91RO244
	91AL394	TOEDHEIDE K.	91BA280		91VE302
STUESSER N.	91ST180		91BA363		91GA349
	91MA297	TOLEDANO J.C.	91BA442		91GA430
STUHR U.	91ST364	TOMKINSON J.	91FI225		91AL432
	91ST515		91TO335		91FU462
STUHRMANN H.B.	91KN336	TORRANCE J.B.	91LA172		91RO464
	91KN348	TRAMPENAU J.	91PE107		91BL484
	91KN461		91TR187		91RO499
STUNAUULT A.	91SC379		91HE188		91ST515
SUCK J.B.	91SU190		91PE189		91TA554
	91AL193		91HE373	VEXKHOVSKAYA K.A.	91BU433
	91VE300	TRANQUADA J.M.	91BO101	VILCHES O.E.	91VI468
	91SU352	TREQUATTRINI F.	91CA1056	VISENTIN L.	91BI534
	91SU472	TRESSAUD A.	91NU386	VISSER D.	91VI325
	91SU497		91LI498		91VI401
SUN B.N.	91CA04G		91RO540		91VI408
SUORTTI I.	91KO475	TRIANAFILLIOIS G.	91PO545		91VI409
SUSHKOV P.A.	91PE1059	TRIEB H.	91JO103		91VI410
SUTTON B.J.	91GA268		91MA473		91DO460
SUZANNE J.	91VI468	TROUNOV V.	91TR471	VOGL G.	91HE188
	91DI276	TRUMP R.	91TR210		91PE189
TACHEZ M.	91RO439	TRUNOV V.	91GU503	VOGT O.	91HE373
	91AL424	TSCHERNITZ M.	91TS11S		91JO230
	91AL425	TUCK J.J.	91TU199	VOGT T.	91LA242
TAILLEFER L.	91TA554	UDOVIC T.J.	91BE366		91HO111
TAJIMA Y.	91MO1001		91AN426		91BE126
TAMBERGS J.J.	91BA125	ULBIG S.	91BE12T		91RU170
TANG H.Y.	91PA509		91MA18T		91ST180
TASSET F.	91TA14G		91UL175		91DE213
	91BR216		91UL178		91CZ285
	91NU328		91UL455		91EF339
	91TA337		91KE494		91CZ384
TAYLOR A.D.	91MU262		91UL513		91SC412
	91HE1039		91BO520		91BO448
	91HA1057		91UL525		91BL541
TERECH P.	91TE220		91UL527	VOIRON J.	91CH374
	91TE406	VACQUIER G.	91GA349	VREDENBERG A.	91FI1012
	91TE482		91GA430	VRIJ A.	91DU112
	91TE483		91OB186		91DU402
THALMEIER P.	91TH356	VALLET M.	91BA288	VRTIS M.L.	91BR15T
THELLIER M.	91HE1033		91CA559		91FA271
THEOPHILOU N.	91SA283				91EC326

## AUTHOR INDEX

VUILLARD L.	91VU322	WYATT A.F.G.	91LA470
WACKER T.	91TI212	WYDER P.	91CH374
WAGNER C.T.	91BE126	YAU P.	91WO194
WAGNER N.J.	91WA1070	YING S.C.	91AL424
WAGNER R.	91KN336		91AL425
	91KN348	YONATH A.	91EI390
	91KN461	YOUNG T.	91GR505
WAGNER W.	91WA378	ZABEL V.	91DI372
WALLNER G.	91MU347	ZACCAI G.	91PA215
WALTER A.	91MA473		91EB358
WANG L.	91FI1009		91ZA514
	91FI1010	ZACHMANN H.G.	91OL310
	91FI1011	ZEIDLER M.D.	91BH331
	91FI1012	ZEILINGER A.	91ED313
WANG P.W.	91LA172	ZEISKE T.	91ST180
WARNER D.D.	91BA125	ZEPPENFELD P.	91VI468
WAXMAN D.	91SC182	ZERGUINE M.	91GI404
WEBSTER P.J.	91WE1027	ZEYEN C.M.E.	91MA436
WEIDENMANN A.	91WA378	ZHAO J.	91KN336
WEINFURTER H.	91MA297		91KN348
WEINSTEIN S.	91EI390		91KN461
WEISS E.	91WE546	ZHIGUNOV D.I.	91CH374
WEITZEL H.	91WI263	ZIA R.K.P.	91MI1055
WELLER M.T.	91GR505	ZIEBECK K.R.A.	91NE223
WELTE W.	91TI212		91BR318
WENK H.R.	91WE162	ZIMMERMANN H.	91DE236
WENKOW-ES-SOUNI M.	91KN348	ZIRKEL A.	91BU177
	91KN336	ZOBKALO I.	91CH374
	91KN461	ZOELLNER H.	91RU170
WERNER R.	91BI387	ZORN R.	91FR275
	91BI534		91RI383
WHITE D.	91MA18T	ZUECHNER H.	91CO340
	91WH532	ZULEHNER W.	91LI289
WHITE R.P.	91BE161		91GU1060
	91PR165		91GU1062
	91CA207	ZVYAGIN A.I.	91CH374
	91CA301		
WICKER A.	91WI218		
WIJNS L.	91LA443		
WILKINSON C.	91WI263		
	91WI446		
WILLIAMS A.	91MA18T		
WILLIAMS J.H.	91CA207		
	91WI357		
	91WI396		
	91WI397		
WILSON C.C.	91GU1061		
WINTER C.	91UL513		
WIPF H.	91ST291		
	91ST364		
	91ST485		
	91ST515		
WISSOCQ J.C.	91HE1033		
WITTMANN J.C.	91WI218		
WITZ J.	91GO306		
WOIKE T.	91RU170		
WOOD M.J.	91WO194		
WORTIS M.	91MI1055		
WROBLEWSKI T.	91IH109		
WULFF M.	91LE1026		
WUTTKE J.	91WU08T		
	91WU512		

## Papers accepted for Publication

(with ILL authors and coauthors)  
arranged by subject - in alphabetical order

### 1. Neutron Instruments and Methods

ALEFELD B., SPRINGER T., HEIDEMANN A.  
Neutron backscattering, a method for high precision measurements of energy transfers and lattice parameters.  
Nuclear Science and Engineering (90AL5146)

BRÜCKEL T.  
A thermal flat cone diffractometer for polarization analysis.  
Physica B (proceedings of the International Conference on Neutron Scattering, Oxford, August 27-30, 1991) (91BR5325)

COOK J., PETRY W., HEIDEMANN A., BARTHELEMY J.-F.  
A dynamic range upgrade for neutron backscattering spectroscopy.  
Nuclear Instruments and Methods (91CO5161)

FIONI G., FAUST H.R., GROSS M.  
Improvement of the Lohengrin spectrometer by using a focussing magnet.  
Proceedings of the Seminar on 'Fission', Pont d'Hoye, Belgium, October 23-25, 1991 (91FI5209)

GRÜNING U., MAGERL A., MILDNER D.F.R.  
Neutron guidance by internal reflections in thin silicon wafers.  
Nuclear Instruments and Methods A (91GR5139)

HOYLER F., BÖRNER H.G., JOLIE J., ULBIG S., WILLIAMS A.  
High resolution  $\gamma$ -ray spectroscopy at ILL.  
Progress in Particle and Nuclear Physics (proceedings, Erice 1991) (91HO5293)

KEARLEY G.J.  
Instrumentation for neutron spectroscopy.  
Spectrochimica Acta (review article : Physical chemistry, neutron scattering) (91KE5206)

KEARLEY G.J.  
Time-focussing with multi-slit disk-choppers - a future spectrometer ?  
Physica B (proceedings of the International Conference on Neutron Scattering, Oxford, August 27-30, 1991) (91KE5221)

KOCSIS M., KULDA J.  
Proposal for a neutron strain measurement apparatus.  
NATO ASI Series (proceedings of a NATO ASI on "Measurement of Residual and Applied Stress using Neutron Diffraction", Oxford, May 18-22, 1991) (91KO5028)

KULDA J., MIKULA P., LUKAS P., KOCSIS M.  
Utilisation of bent Si crystals for elastic strain measurements.  
Physica B (proceedings of the International Conference on Neutron Scattering, Oxford, August 27-30, 1991) (91KU5101)

LINDNER P., MAY R.P., TIMMINS P.A.  
Upgrading of the SANS instrument D11 at the ILL.  
Physica B (proceedings of the International Conference on Neutron Scattering, Oxford, August 27-30, 1991) (91LI5096)

MAMPE W.  
Bestimmung der Kopplungskonstanten der elektro-schwachen Wechselwirkung.  
GSI-Reports (91MA5223)

McINTYRE G.J.  
Position-sensitive detectors in single-crystal diffractometry.  
Neutron News (91MC5087)

MUTKA H.  
Focussing monochromator - Fermi-chopper time-of-flight spectrometer.  
Physica B (proceedings of the International Conference on Neutron Scattering, Oxford, August 27-30, 1991) (91MU5083)

TASSET F., CHUPP T., PIQUE J.P., STEINHOF A., THOMPSON A., WASSERMAN E., ZIADE M.  
First test at ILL of a gaseous  $^3\text{He}$  neutron polarization filter.  
Physica B (proceedings of the International Conference on Neutron Scattering, Oxford, August 27-30, 1991) (91TA5103)

STUNAUAT A., ANDERSEN K.H., BLANC Y., FÅK B., GODFRIN H., GUCKELBERGER K., SCHERM R.  
TOF spectroscopy : energy calibration and consistency check.  
Physica B (proceedings of the International Conference on Neutron Scattering, Oxford, August 27-30, 1991) (91ST5229)

### 2. Theory

BOWLEY R.M., NOZIERES P.  
The effect of heat currents on the stability of the liquid solid interface.  
Journal de Physique I (91BO5175)

FOURCADE B., PLISCHKE M.  
Monte Carlo analysis of bond-diluted tethered membranes  
Ecole sur les "Phénomènes dynamiques aux interfaces, surfaces et membranes", Les Houches, Feb. 19-28, 1991 (91FO5050)

FOXONET N., BERNIER P., VOIT J.  
Conductivity of n-doped polyacetylene : Dependence on doping level and temperature.  
Journal de Chimie Physique (Comptes Rendus des Journées des Polymères Conducteurs) (91FO5234)

LHUILIER D., NOZIERES P.  
Volume averaging of slightly non-homogeneous suspensions.  
Physica A (90LH5115)

LOSS D., HOLDSWORTH P.C.W.  
Hopping conductivity for localized electronic states - Liouville space formalism.  
Physica B (89LO5180)

NOZIERES P.  
The strange properties of Fermi liquids with a finite range interaction.  
Journal de Physique I (91NO5291)

ORTIZ G., NUÑEZ-REGUEIRO M.D., LACROIX C., COQBLIN B.  
Selfconsistent method for the two-impurity Anderson model.  
Journal of Magnetism and Magnetic Materials (91OR5276)

NUÑEZ-REGUEIRO M.D., LACROIX C., BALLOU R., LELIEVRE E.  
S=1 Ising model on a triangular lattice.  
Journal of Magnetism and Magnetic Materials (91NU5278)

SAITO Y., UWAHA M., SEKI S.

Flow-induced first order transition of the aggregation in a diffusion field.  
Proceedings of the 1st International Symposium on Slow Dynamics in  
Condensed Matter, Towa University, 1991 (91SA5344)

TREMBLAY A.-M.S., TREMBLAY R.R., ALBINET G., FOURCADE B.  
How many correlation lengths for multifractals ?  
Physica D (91TR5151)

UWAHA M., SAITO Y., SEKI S.

Aggregation in a diffusion field - velocity selection via fractal dimension of  
DLA and flow-induced first order transition.

Proceedings of the Workshop on "Dynamical Phenomena at Interfaces,  
Surfaces and Membranes", Les Houches, Feb. 18-28, 1991, edited by  
Beysens D., Boccara and Forgacs G. (91UW5097)

UWAHA M., SAITO Y.

Kinetic smoothing and roughening of a step with surface diffusion.  
Physical Review Letters (91UW5134)

VOIT J.

Phase diagram and correlation functions of the half-filled extended Hubbard  
model in one dimension.

Physical Review B (91VO5089)

VOIT J., COUSTEL N., BERNIER P., FISCHER J.E.

Percolation in conducting polymers - Well and alive !  
in "Electronic Properties of Conjugated Polymers", edited by Kuzmany H.,  
Mehring M. and Roth S., Springer Series in Solid State Sciences,  
(proceedings of an International Winter School, Kirchberg, Austria,  
March 9-16, 1991) (91VO5041)

WORTIS M., SEIFERT U., BERNDL K., FOURCADE B., MIAO L., RAO  
M., ZIA R.K.P.

Curvature-controlled shapes of lipid-bilayer vesicles : budding, vesiculation  
and other phase transitions.

Proceedings of the Workshop "Dynamical Phenomena at Interfaces,  
Surfaces and Membranes", Les Houches, Feb. 18-28, 1991, edited by  
Beysens D., Boccara and Forgacs G. (91WO5070).

### 3. Fundamental and Nuclear Physics

CHOUDEUR M., PENDLEBURY J.M., SMITH K.F.

Surface density profiles and the rate of loss of stored ultracold neutrons.  
Nuclear Instruments and Methods in Physics Research (91CH5300)

KLAY N., KÄPPELER F., BEER H., SCHATZ G., BÖRNER H.G.,  
HOYLER F., ROBINSON S.J., SCHRECKENBACH K., KRUSCHE B.,  
MAYERHOFER U., HLAWATSCH G., LINDNER H., VON EGIDY T.,  
ANDREJTSCHIEFF W., PETKOV P.

The nuclear structure of  $^{176}\text{Lu}$  and its astrophysical consequences.  
Physical Review C (90KA5094)

JOLIE J., BÖRNER H.G.

Lifetime measurements in medium heavy nuclei using the  $\gamma$ -ray induced  
doppler broadening (grid) technique.

Plenum Publishing (Proceedings of the Workshop 'Nuclear Shapes and  
Nuclear Structure at Low Excitation Energies', Cargese June. 3-7, 1991)  
(91JO5072)

KAUFMANN J., BOUCHENEB N., MEDKOUR G., ASGHAR M.,  
GOENNENWEIN F., MOLLENKOPF W., BARREAU G., DOAN T.P.,  
LEROUX B., SICRE A., GELTENBORT P.

Fragment yields from the fission reactions  $^{232}\text{U}(n,f)$  and  $^{239}\text{Pu}(n,f)$ .  
Proceedings of the International Conference on Nuclear Data for Science  
and Technology, Jülich, May 13-17, 1991 (91KA5055)

KAUFMANN J., MOLLENKOPF W., GOENNENWEIN F.,  
GELTENBORT P., OED A.

Cold deformed fission in  $^{232}\text{U}(n,f)$  and  $^{239}\text{Pu}(n,f)$ .  
Zeitschrift für Physik A (91KA5153)

LAST J.

Angular correlations in free neutron decay.

Editions Frontières (proceedings of the XIth Moriond Workshop 'Tests of  
fundamental laws in physics', Les Arcs, Jan. 26 - Feb. 2, 1991) (91LA5159)

PENDLEBURY J.M.

Steps to improve the measurement of the neutron electric dipole moment.  
Elsevier Science Publishers (proceedings of the EPS Conference on  
'Hadronic structure and electroweak interactions', Nikhef, Amsterdam,  
August 5-10, 1991) (91PE5301)

ROBINSON S.J., JOLIE J., BÖRNER H.G., ULBIG S., JANSSEN D.

Excited level lifetime measurements following very low energy nuclear  
recoils.

Hyperfine Interactions (91RO5327)

SCHOENERT S., SCHRECKENBACH K., NEUMAIER S.,  
VON FEILITZCH I.

Experimental limit on a 17 keV neutrino branch in the  $\beta$  decay of  $^{177}\text{Lu}$   
World Scientific Publ. (proceedings of the Workshop 'Beyond the Standard  
Model of Electroweak Interaction', Valencia (Spain), 1991 (91SC5338)

SCHRECKENBACH K., MAMPE W.

The lifetime of the free neutron.

Journal of Physics G : Nuclear and Particle Physics (topical review)  
(91SC5066)

WAGEMANS C., DRUYTS S., WEIGMANN H., BARTHELEMY R.,  
SCHILLEBEECKX P., GELTENBORT P.

(n,p) and (n, $\alpha$ ) cross-section measurements with astrophysical applications.  
Proceedings of the International Conference on Nuclear Data for Science  
and Technology, Jülich, May 13-17, 1991 (91WA5054)

### 4. Structural and Magnetic excitations

AMORETTI G., BLAISE A., CACIUFFO R., DI COLA D., FOURNIER  
J.M., HUTCHINGS M.T., LANDER G.H., OSBORN R., SEVERING A.,  
TAYLOR A.D.

A neutron scattering investigation of the electronic ground state of  
neptunium dioxide.

Journal of Physics: Condensed Matter (91AM5040)

AYACHE C., CURRAT R., MOLINIE P.

Study of the mode-softening in  $\text{NbSe}_2$ -2H.

Physica B (proceedings of the International Conference on Neutron  
Scattering, Oxford, August 27-30, 1991) (91AY5199)

BELLOUARD C., HENNION M., MIREBEAU I., DIANOUX A.J.,  
CAIGNAERT V.,

Inelastic neutron study in superconducting  $\text{YBa}_2(\text{Cu}_{1-x}\text{Co}_x)_3\text{O}_7$ .

Journal of Magnetism and Magnetic Materials,  
(proceedings of the International Conference on Magnetism, ICM'91,  
Edinburgh, September 2-6, 1991) (91BE5110)

BLANCO J.A., GÓMEZ-SAL J.C., RODRÍGUEZ-FERNÁNDEZ J.,  
SANDONÍS J., BARANDIARÁN J.M.

Magnetic excitations in  $\text{CeNi}_x\text{Pt}_{1-x}$  ferromagnetic Kondo lattice  
compounds (91BL5311)

- BOOTHROYD A.T., STIRLING W.G., CURRAT R., BERNHOEFT N.R.,  
McK PAUL D., SHIHUB S.I.  
Neutron scattering study of the electron-phonon interaction in  
superconducting niobium.  
Physica B (proceedings of the International Conference on Neutron  
Scattering, Oxford, August 27-30, 1991) (91BO5200)
- BRAMWELL S.T., HUTCHINGS M.T., FÁK B.  
The dynamic critical scattering of a 2D-planar ferromagnet : Rb<sub>2</sub>CrCl<sub>4</sub>.  
Physica B (proceedings of the International Conference on Neutron  
Scattering, Oxford, August 27-30, 1991) (91BR5230)
- BROWN P.J., HAYDEN S.M., LANDER G.H., ZARESTKY J., STASSIS  
C., METCALF P., HONIG J.M.  
Observation of incommensurate two-dimensional magnetic correlations in  
La<sub>1.8</sub>Sr<sub>0.2</sub>NiO<sub>4</sub>.  
Physica B (proceedings of the International Conference on Neutron  
Scattering, Oxford, August 27-30, 1991) (91BR5075)
- BRÜCKEL T., DORNER B., GUKASOV A., PLAKHTY V.  
An evidence for the exchange origin of the magnon gap in the garnet  
Ca<sub>3</sub>Fe<sub>2</sub>Ge<sub>3</sub>O<sub>12</sub>.  
Physics Letters A (91BR5248)
- CACIUFFO G., AMORETTI G., BLAISE A., FOURNIER J.M.,  
HUTCHINGS M.T., LANDER G.H., OSBORN R., SEVERING A.,  
TAYLOR A.D.  
Neutron inelastic experiments on actinide dioxides : search for crystal field  
excitations.  
Physica B (proceedings of the International Conference on Neutron  
Scattering, Oxford, August 27-31, 1991) (91CA5136)
- CLARKE S.J., HARRISON A., MASON T.E., McINTYRE G.J., VISSER D.  
Magnetic ordering and fluctuations in the S = 1/2 square Heisenberg  
antiferromagnet Cu(DCO<sub>2</sub>)<sub>2</sub>.4D<sub>2</sub>O.  
Physical Review B, Rapid Communications (91CL5196)
- DIANOUX A.J., ROSSEINSKY M.J., PRASSIDES K., DAY P.  
Phonon density of states of (Ba,K) (Pb,BiSb)O<sub>3</sub> ceramic oxides  
in High Temperature Superconductors II.  
(proceedings of a NATO-ASI, Porto Carras, Halkidiki, Greece,  
August 18-31, 1991) (91DI5225)
- DORNER B.  
Structural excitations and phase transformation.  
Physica B (proceedings of the International Conference on Neutron  
Scattering, Oxford, August 27-31, 1991) (91DO5143)
- DU PLESSIS P. de V., LANDER G.H., STRYDOM A.M., FÁK B.  
Phonon softening in UO<sub>2</sub>.  
Physica B (proceedings of the International Conference on Neutron  
Scattering, Oxford, August 27-31, 1991) (91DU5137)
- ENDERLE M., KAKURAI K., STEINER M., DORNER B.  
Eigenvectors in the Haldane-system CsNiCl<sub>3</sub>.  
Physica B (proceedings of the International Conference on Neutron  
Scattering, Oxford, August 27-30, 1991) (91EN5098)
- FULTON S., NAGLER S.E., COWLEY R.A., NEEDHAM L.M.  
Spin waves in the quasi two-dimensional antiferromagnet KFeF<sub>4</sub>.  
Physica B (proceedings of the International Conference on Neutron  
Scattering, Oxford, August 27-30, 1991) (91EL5354)
- GARCÍA-MUÑOZ J.L., RODRÍGUEZ-CARVAJAL J., LACORRE P.  
Electronically induced structural distortion across the metal-insulator  
transition in RNiO<sub>3</sub> (R=Pr, Nd, Sm).  
Physica B (proceedings of the International Conference on Neutron  
Scattering, Oxford, August 27-30, 1991) (91GA5185)
- HAYDEN S.M., LANDER G.H., ZARESTKY J., BROWN P.J., STASSIS  
C., METCALF P., HONIG J.M.  
Incommensurate magnetic correlations in La<sub>1.8</sub>Sr<sub>0.2</sub>NiO<sub>4</sub>.  
Physical Review Letters (91HA5069)
- HEAP R.T., MITCHELL P.W., NEEDHAM L.M.  
Low energy spin wave excitations in Ni<sub>60</sub>Fe<sub>40</sub>.  
Journal of Magnetism and Magnetic Materials (proceedings of the  
International Conference on Magnetism, Edinburgh, Sept. 2-6, 1991)  
(91HE5356)
- HEIMING A., PETRY W., TRAMPENAU J.  
Are martensitic phase transitions in pure group 3 and 4 metals driven by  
lattice vibrations ?  
Proceedings of the European Symposium on Martensitic transformation and  
shape memory properties, Aussois, Sept. 1991 (91HE5093)
- HENNION M., MIREBEAU I., BOUDARENE L., BELLOUARD C.,  
JEHANNO G., DIANOUX A.J., CAIGNAERT V.,  
Iron spin fluctuations in the orthorhombic phase of YBa<sub>2</sub>(Cu<sub>1-x</sub>Fe<sub>x</sub>)<sub>3</sub>O<sub>7</sub> :  
an inelastic neutron scattering study.  
Physica B (proceedings of the International Conference on Neutron  
Scattering, Oxford, August 26-30, 1991) (91HE5111)
- HENNION M., BELLOUARD C., MIREBEAU I., BLANK H.,  
DORMANN, DJEGA-MARIADASSOU C.  
Static and dynamic study of fine particles by neutron scattering.  
Proceedings of the International Workshop on Studies of Magnetic  
Properties of Fine Particles and their relevance to Materials Science, Roma,  
Italy, November 4-8, 1991 (91HE5367)
- IBARRA M.R., MARQUINA C., ALGARABEL P.A., MURANI A.P.,  
RITTER C., PAVLOVIC A.S.  
A study of the structural, magnetic and magnetoelastic behavior and CEF  
excitations in RCu intermetallics.  
in "Spanish Scientific Research using Neutron Scattering Techniques", eds.  
Gómez-Sal J.C., Rodríguez-Gonzalez F., Plazaola F., Rojo T. (Servicio de  
Publicaciones de la Universidad de Cantabria) (91IB5339)
- JONES D.L., LANGRIDGE S., STIRLING W.G., LANDER G.H.,  
REBIZANT J., SPIRLET J.C., ALBA M., VOGT O.  
Critical scattering measurements on neptunium arsenide.  
Physica B (proceedings of the International Conference on Neutron  
Scattering, Oxford, August 27-30, 1991) (91JO5100)
- LARTIGUE C., MEZEI F., PAPPAS C., ALBA M.  
Unusual critical dynamics in AuFe reentrant ferromagnets.  
Physica B (91LA5286)
- MARSHALL W.G., McEWEN K.A., FORT D.  
Neutron magnetic scattering from UPb<sub>3</sub>.  
Physica B (proceedings of the International Conference on Neutron  
Scattering, Oxford, August 27-30, 1991) (91MA5188)
- MARSHALL W.G., MURANI A.P., McEWEN K.A.  
5f-electron spin dynamics in U(Sn<sub>3-x</sub>In<sub>x</sub>).  
Journal of Magnetism and Magnetic Materials (proceedings of the  
International Conference on Magnetism, ICM'91, Edinburgh,  
Sept. 2-6, 1991) (91MA5187)
- MAYER H.M., STEINER M., STÜSSER N., WEINFURTER H.,  
DORNER B., LINDGARD P.A., CLAUSEN K.N., HOCK S.,  
VERHOEF R.  
Inelastic neutron scattering measurements on Nd<sub>2</sub>F<sub>14</sub>B and Y<sub>2</sub>Fe<sub>14</sub>B  
single crystals.  
Journal of Magnetism and Magnetic Materials (proceedings of the  
International Conference on Magnetism, ICM'91, Edinburgh,  
September 2-6, 1991) (91MA5076)

- MURANI A.P., TAYLOR A.D., OSBORN R., BOWDEN Z.A.  
High energy paramagnetic spectral response of the valence fluctuation compound  $\text{YbAl}_2$ .  
Philosophical Magazine (91MU5337)
- MUTKA H., PAYEN C., MOLINIE P., SOUBEYROUX J.L., COLOMBET P., TAYLOR A.D.  
Magnetic correlations in the  $S=1$  quasi-one-dimensional heisenberg antiferromagnet  $\text{AgVP}_2\text{S}_6$ .  
Physica B (proceedings of the International Conference on Neutron Scattering, Oxford, August 27-30, 1991) (91MU5084)
- PAYEN C., MUTKA H., SOUBEYROUX J.L., MOLINIE P., COLOMBET P.  
Static and dynamic properties of the quasi-1D Heisenberg antiferromagnets  $\text{AgVP}_2\text{S}_6$  ( $S=1$ ) and  $\text{AgCrP}_2\text{S}_6$  ( $S = 3/2$ ).  
Journal of Magnetism and Magnetic Materials (proceedings of the International Conference on Magnetism, ICM'91, Edinburgh, Sept. 2-6, 1991) (91PA5082)
- PRASSIDES K., ROSSEINSKY M.J., DIANOUX A.J., DAY P.  
Phonon softening in ceramic superconductors.  
Physica B (proceedings of the International Conference on Neutron Scattering, Oxford, August 27-30, 1991) (91PR5182)
- PRASSIDES K., ROSSEINSKY M.J., DIANOUX A.J., DAY P.  
Temperature and composition evolution of the phonon density of states in  $(\text{Ba,K})(\text{Pb,Bi,Sb})\text{O}_3$  ceramic oxides.  
Journal of Physics : Condensed Matter (91PR5183)
- ROSSAT-MIGNOD J., REGNAULT L.P., VETTER C., BOURGES P., BURLET P., BOSSY J., HENRY J.Y., LAPERTOT G.  
Spin dynamics in the high  $T_c$  system  $\text{YBa}_2\text{Cu}_3\text{O}_{6+x}$ .  
Physica B (proceedings of the International Conference on Neutron Scattering, Oxford, August 27-30, 1991) (91RO5359)
- ROSSAT-MIGNOD J., REGNAULT L.P., VETTER C., BOURGES P., BURLET P., BOSSY J., HENRY J.Y., LAPERTOT G.  
Inelastic neutron scattering study of the spin dynamics in  $\text{YBa}_2\text{Cu}_3\text{O}_{6.92}$ .  
Journal of Magnetism and Magnetic Materials (proceedings of the International Conference on Magnetism, Edinburgh, Sept. 2-6, 1991) (91RO5358)
- SCHMID B., DORNER B., VISSER D., STEINER M.  
Magnetic field and temperature dependent correlations in the singlet ground state system  $\text{CsFeBr}_3$ .  
Journal of Magnetism and Magnetic Materials (proceedings of the International Conference on Magnetism, ICM'91, Edinburgh, September 2-6, 1991) (91SC5114)
- SCHMID B., DORNER B., VISSER D., STEINER M.  
Temperature and magnetic field dependent correlations in the singlet ground state system  $\text{CsFeBr}_3$ .  
Zeitschrift für Physik B (91SC5181)
- SCHOBER H.R., PETRY W.  
Lattice vibrations.  
Chapter 5 in 'Materials Science and Technology', R.W. Cahn, P. Haasen, E.J. Kramer, eds., Volume 1 (V. Gerold ed.), Weinheim: Verlag Chemie (91SC5362)
- SEVERING A.  
Neutron studies of heavy fermions.  
Journal of Magnetism and Magnetic Materials (proceedings of the International Conference on Magnetism, Edinburgh, Sept. 2-6, 1991) (91SE5357)
- SEVERING A., THOMPSON J.D., CANFIELD P.C., FISK Z., RISEBOROUGH P.  
Gap in the magnetic excitation spectrum of  $\text{Ce}_3\text{Bi}_4\text{Pt}_3$ .  
Journal of the Less Common Metals (proceedings of the 19th Rare Earth Conference, Lexington, USA, 1991) (91SE5039)
- STAUB U., ALLENSPACH P., MESOT J., FURRER A., BLANK H., MUTKA H.  
Neutron spectroscopy and diffraction studies of the high- $T_c$  superconductor  $\text{HoBa}_2\text{Cu}_3\text{O}_x$ .  
Physica B (proceedings of the International Conference on Neutron Scattering, Oxford, August 27-30, 1991) (91ST5268)
- TENNANT D.A., McMORROW D.F., NAGLER S.E., FÁK B.  
Spin waves in the spin-flop phase of  $\text{RbMnF}_3$ .  
Physica B (proceedings of the International Conference on Neutron Scattering, Oxford, August 27-30, 1991) (91TE5263)
- TIETZE-JAENSCH H., SEIGER D., JAITNER H., GEICK R., SCHWEISS P., TREUTMANN W., REGNAULT L.P., FÁK B.  
Magnetic disorder in the spin-flop phase of  $\text{Rb}_2\text{MnCl}_4$ .  
Journal of Magnetism and Magnetic Materials (proceedings of the International Conference on Magnetism, ICM'91, Edinburgh, Sept. 2-6, 1991) (91TI5231)
- TRAMPENAU J., PETRY W., HEIMING A.  
Phonons in the bcc phase of Sc.  
Physica B (proceedings of the International Conference on Neutron Scattering, Oxford, August 27-30, 1991) (91TR5094)

## 5. Crystal and Magnetic Structures

### 5a - Crystallography of Non-Magnetic Systems

- AMORÓS P., IBAÑEZ R., BELTRÁN A., MARCOS M.D., BELTRÁN D., RODRÍGUEZ-CARVAJAL J.  
Thermally induced transformations in layered oxovanadium phosphate. in "Spanish Scientific Research using Neutron Scattering Techniques", eds. Gómez-Sal J.C., Rodríguez-Gonzalez F., Plazaola F., Rojo T. (Servicio de Publicaciones de la Universidad de Cantabria). (91AM5341)
- BERTHOLD H.J., VONHOLDT E., WARTCHOW R., VOGT T.  
X-ray and neutron diffraction investigation at 298 K of  $\text{NH}_4\text{I.NH}_3$  and  $\text{ND}_4\text{I.ND}_3$  containing the cation  $\text{H}_3\text{N-H...NH}_3^+$  and  $\text{D}_3\text{N-D...ND}_3^+$ .  
Zeitschrift für Kristallographie (91BE5126)
- BERTHOLD H.J., VONHOLDT E., WARTCHOW R., VOGT T.  
Neutron diffraction study of the orthorhombic low-temperature phase of  $\text{N}_2\text{D}_7\text{I}$  and X-ray investigations of the tetragonal and orthorhombic phases of  $\text{N}_2\text{H}_7\text{I}$ .  
Zeitschrift für Kristallographie (91BE5154)
- BUSSEREAU I., BELKHIRIA M.S., GRAVEREAU P., BOIREAU A., SOUBEYROUX J.L., OLAZCUAGA R., LE FLEM G.  
The structure of  $\text{CuZr}_2(\text{PO}_4)_3$  by X-ray and powder neutron diffraction.  
Acta Crystallographica (91BU5259)
- CHATTOPADHYAY T., VON SCHNERING H.G., STANSFIELD R.F.D., McINTYRE G.J.  
X-ray and neutron diffraction study of the crystal structure of  $\text{MnS}_2$ .  
Zeitschrift für Kristallographie (90CH5163)
- CZJZEK M., VOGT T., FUESS H.  
The location of mesitylene adsorbed in rare earth exchanged Y-Zeolite. Zeolites (91CZ5049)
- CZJZEK M., JOBIC H., FITCH A.N., VOGT T.  
Direct determination of proton positions in D-Y and H-Y samples by neutron powder diffraction.  
Journal of Physical Chemistry (91CZ5328)

- FITCH A.N., COCKCROFT J.  
The structure of solid tribromofluoromethane  $\text{CFBr}_3$  by powder neutron diffraction.  
*Zeitschrift für Physik* (91FI5304)
- FITCH A.N., COCKCROFT J.  
The structure of solid carbon tetrafluoride.  
*Zeitschrift für Physik* (91FI5305)
- HEWAT A.W.  
Neutron diffraction, structural inorganic chemistry and high temperature superconductors.  
*Nuclear Science and Engineering* (90HE5141)
- HEWAT A.W.  
Limits to  $T_c$  in Oxide Superconductors studied by neutron powder diffraction.  
*Physica B* (proceedings of the International Conference on Neutron Scattering, Oxford, August 27-30, 1991) (91HE5095)
- HOWARD A.K., KELLER P.A., VOGT T., TAYLOR A.L., DIX N.D., SPENCER J.L.  
The low-temperature neutron diffraction study of  $[\text{ReH}_5(\text{PPhPr}_2)_2(\text{SiHPh}_2)_2]$ , and the low-temperature X-ray diffraction study of  $[\text{ReH}_5(\text{PCyp}_3)_2(\text{SiH}_2\text{Ph})_2]$ .  
*Acta Crystallographica B* (91HO5157)
- KELLERSOHN T., LUTZ H.D., VOGT T., DELAPLANE R.G., OLOVSSON I.  
Structural instabilities of the trigonally coordinated water molecules in  $\text{Ba}(\text{IO}_3)_2 \cdot \text{H}_2\text{O}$  and  $\text{Pb}(\text{ClO}_3)_2 \cdot \text{H}_2\text{O}$  studied by X-ray and neutron diffraction at 25 and 295 K.  
*Acta Crystallographica B* (91KE5156)
- IBARRA M.R., MARQUINA C., MOZE O., IBBERSON R.M., PAVLOVIC A.S., RITTER C.  
Structural transformation in  $\text{Tb}_{0.1}\text{Y}_{0.9}\text{Cu}$ .  
*Physica B* (proceedings of the International Conference on Neutron Scattering, Oxford, August 27-30, 1991) (91IB5308)
- IBEL K., MATULL R., RUPP R.A., EISCHKOETTER P., HEHMANN J.,  
Light-induced volume phase holograms for cold neutrons.  
*Proceedings of SPIE's International Symposium on Optical Applied Science and Engineering, San Diego, California, July 21-26, 1991* (91IB5063)
- ISNARD O., SOUBEYROUX J.L., MIRAGLIA S., FRUCHART D., GARCÍA L.M., BARTOLOME J.  
Neutron powder diffraction study of the desorption of deuterium in  $\text{Nd}_2\text{Fe}_{17}\text{D}_{x=5}$ .  
*Physica B* (proceedings of the International Conference on Neutron Scattering, Oxford, August 27-30, 1991) (91IS5210)
- ISNARD O., SOUBEYROUX J.L., MIRAGLIA S., FRUCHART D., GARCÍA L.M., BARTOLOME J.  
Neutron powder diffraction study of the reaction of  $\text{Nd}_2\text{Fe}_{17}$  compounds with nitrogen gas.  
*Physica B* (proceedings of the International Conference on Neutron Scattering, Oxford, August 27-30, 1991) (91IS5211)
- MEDARDE M., RODRÍGUEZ-CARVAJAL J., OBRADORS X., VALLET-REGI M., GONZALES-CALBET J.M., SAYAGUES M.J.  
Oxygen vacancy ordering in  $\text{La}_{2-x}\text{Sr}_x\text{NiO}_{4-\delta}$ .  
*Physica B* (proceedings of the International Conference on Neutron Scattering, Oxford, August 27-30, 1991) (91ME5092)
- MONDAL S., CYWINSKI R., KILCOYNE S.H., RAINFORD B.D., RITTER C.,  
Low temperature structural distortions in  $\text{RMn}_2$ .  
*Physica B* (proceedings of the International Conference on Neutron Scattering Oxford, August 27-30, 1991) (91MO5107)
- MURSIC Z., VOGT T., BOYSEN H., FREY F.  
Single-crystal neutron diffraction study of metamict zircon up to 2000 K.  
*Journal of Applied Crystallography* (91MU5155)
- NAVARRO J.M., CALDES M.T., GÓMEZ-ROMERO P., CASAN-PASTOR N., RODRÍGUEZ-CARVAJAL J., OBRADORS X., FUERTES A.  
Neutrons studies of high  $T_c$  superconductors.  
in "Spanish Scientific Research using Neutron Scattering Techniques", eds. Gómez-Sal J.C., Rodríguez-Gonzalez F., Plazaola F., Rojo T. (Servicio de Publicaciones de la Universidad de Cantabria) (91NA5254)
- NAVARRO J.M., FUERTES A., GÓMEZ-ROMERO P., RODRÍGUEZ-CARVAJAL J.  
Crystal structure of  $\text{La}_{1.85}\text{Ba}_{0.15}\text{CaCu}_2\text{O}_{6+y}$  determined by neutron powder diffraction.  
*Solid State Communications* (91NA5280)
- PAYER A., SCHMALZ M., PAULUS W., SCHÖLLHORN R., SCHLÖGL, RITTER C.  
Formation of  $\text{Cu}_3^{2+}$  clusters : structure, bonding and topotactic reactivity of chalcogen spinels  $\text{Cu}_{1\pm y}\text{Cr}_2\text{Se}_3\text{Br}$ .  
*Journal of Solid State Chemistry* (91PA5144)
- PILLIERE H., SOUBEYROUX J.L., GOLDMANN M., BEGUIN F.  
Physintercalation of alkanes in  $\text{CsC}_{24}$  : influence of the molecular size on the structural modifications.  
*Materials Science Forum* (proceedings of the ISIC 6, Orléans, June 1991) (91PI5201)
- PLANES A., MANOSA L.I., VIVES E., RODRÍGUEZ-CARVAJAL J., MORIN M., GUENIN G., MACQUERON J.L.  
Neutron diffraction study of long-range atomic order in Cu-Zn-Al shape memory alloys.  
*Journal of Physics : Condensed Matter* (91PL5219)
- RODRÍGUEZ-CARVAJAL J.  
Difracción de neutrones por muestras policristalinas : reactores, fuentes pulsadas, avances recientes en el análisis de datos.  
*Proceedings of una Conferencia del Seminario sobre "Caracterización de Materiales : Avances Teóricos y Experimentales en la Metodología de la Difracción", Universidad Internacional Menéndez Pelayo, Eds. C. Miratvilles y J. Rius* (91RO5255)
- RODRÍGUEZ-CARVAJAL J.  
Neutron powder diffraction for the characterization of structural defects in crystalline solids.  
*Plenum Press, NATO ASI Series, Eds. C.Catlow and M.Gregorkiewitz, (proceedings of a NATO ASI on Defects and Disorder in Crystalline and Amorphous Solids, Madrid, Sept. 15-28, 1991* (91RO5236)

### 5b - Crystallography of Magnetic Systems

- ALONSO J., RASINES I., RODRÍGUEZ-CARVAJAL J.  
Nuclear and magnetic structures of the ordered spinels  $\text{Co}_5\text{TeO}_8$  and  $\text{Zn}_2\text{Co}_3\text{TeO}_8$ .  
*Proceedings of the 2nd European Conference on Advanced Materials and Processes, EUROMAT 91, Cambridge, July 22-24, 1991* (91AL5238)
- BALLOU R., OULADDIAF B., BROWN P.J., NUÑEZ-REGUEIRO M.D., LACROIX C.  
Exotic field-induced transition in a frustrated itinerant antiferromagnet.  
*Physical Review. Rapid Communication* (91BA5203)
- BALLOU R., LACROIX C., NUÑEZ-REGUEIRO M.D.  
Competition between frustration and magnetic instability in  $\text{RMn}_2$  compounds.  
*Journal of Magnetism and Magnetic Materials* (91BA5277)

- BALLOU R., GAYDUKOVA I.Y., MARKOSYAN A.S., OULADDIAF B.,  
Study of the Mn-moment instability in the TbMn<sub>2</sub> intermetallic compound  
by substitutions of Fe for Mn.  
Journal of Magnetism and Magnetic Materials (proceedings of the  
International Conference on Magnetism, Edinburgh, September 2-7, 1991)  
(91BA5130)
- BALLOU R., BROWN P.J., DEPORTES J., MARKOSYAN A.S.,  
OULADDIAF B.  
Exchange frustration and metastability of the magnetic structure of TbMn<sub>2</sub>.  
Journal of Magnetism and Magnetic Materials (proceedings of the  
International Conference on Magnetism, Edinburgh, September 2-7, 1991)  
(91BA5131)
- BARANDIARÁN J.M., BLANCO J.A., ESPESO J.J., FERNÁNDEZ-  
BARQUÍN L., GÓMEZ-SAL J.C., PLAZAOLA F., RODRIGUEZ-  
FERNÁNDEZ J., SANDONÍS J.J.  
Neutron scattering studies in some rare-earths compounds,  
in "Spanish Scientific Research using Neutron Scattering Techniques  
(1986-1991)", eds. Gómez-Sal J.C., Rodríguez-Gonzalez F., Plazaola F.,  
Rojo T. (Servicio de Publicaciones de la Universidad de Cantabria)  
(91BA5345)
- BASTIE P., BELLET D., ROYER A., BARUCHEL J.  
Two non destructive techniques for the investigation of single grain turbine  
blades :  $\gamma$ -ray diffractometry and neutron topography.  
Proceedings of the 8th International Colloquium 'Progrès dans les méthodes  
d'investigation des métaux et nouveaux matériaux', St Etienne,  
November 20-21, 1991 (91BA5361)
- BATLLE X., CABAÑAS M.V., OBRADORS X., VALLET M.,  
RODRÍGUEZ-CARVAJAL J.  
Neutron diffraction studies of M-type hexagonal ferrites:  
from ferrimagnetism to spin-glass behaviour,  
in "Spanish Scientific Research using Neutron Scattering Techniques", eds.  
Gómez-Sal J.C., Rodríguez-Gonzalez F., Plazaola F., Rojo T. (Servicio de  
Publicaciones de la Universidad de Cantabria) (91BA5342)
- BELLITO C., DAY P.,  
Organic-intercalated halogenochromates (II) : low dimensional magnets.  
Journal of Mat. Chem. (91BE5037)
- BLANCO J.A., GIGNOUX D., GÓMEZ-SAL J.C., RODRÍGUEZ-  
CARVAJAL J., RODRÍGUEZ-FERNÁNDEZ J., SCHMITT D.  
Magnetic structures of the orthorhombic GdNi<sub>1-x</sub>Cu<sub>x</sub> compounds.  
Physica B (proceedings of the International Conference on Neutron  
Scattering, Oxford, August 27-30, 1991) (91BL5241)
- BLANCO J.A., FERNÁNDEZ-BARQUÍN L., GIGNOUX D., GÓMEZ-  
SAL J.C., RODRÍGUEZ-CARVAJAL J., RODRÍGUEZ-FERNÁNDEZ J.  
Magnetic structures and Cerium moment reduction in the CeNi<sub>x</sub>Pt<sub>1-x</sub>  
ferromagnetic Kondo lattices.  
Journal of Magnetism and Magnetic Materials (proceedings of the  
International Conference on Magnetism, ICM'91, Edinburgh,  
Sept. 2-6, 1991) (91BL5242)
- BOOTH J.G., COSTA M.M.R., RODRÍGUEZ-CARVAJAL J., PAIXÃO J.A.  
Magnetic phase diagram of the dilute Cr-Ge system.  
Journal of Magnetism and Magnetic Materials (proceedings of the  
International Conference on Magnetism, ICM'91, Edinburgh,  
Sept. 2-6, 1991) (91BO5239)
- BROWN P.J., NUNEZ V., TASSET F., FORSYTH J.B.  
Extinction in mixed magnetic and nuclear reflections. A study of the  
magnetic structure of TbAlO<sub>3</sub> using neutron polarimetry and integrated  
intensity measurements.  
Acta Crystallographic A (91BR5127)
- BROWN P.J., OULADDIAF B., BALLOU R., DEPORTES J.,  
MARKOSYAN A.S.  
Mn-moment instability in the TbMn<sub>2</sub> intermetallic compound.  
Journal of Physics : Condensed Matter (91BR5133)
- BROWN P.J., DEPORTES J., NEUMANN K.U., ZIEBECK K.R.A.  
High temperature magnetization distribution in nickel.  
Journal of Magnetism and Magnetic Materials (proceedings of the  
International Conference on Magnetism, ICM'91, Edinburgh,  
Sept. 2-6, 1991) (91BR5191)
- BRÜCKEL T., PRANDL W., HAGDORN K.  
Neutron scattering investigation of the magnetic structure and phase  
transitions in CoNiTAC mixed crystals.  
Journal of Magnetism and Magnetic Materials (proceedings of the  
International Conference on Magnetism, ICM'91, Edinburgh,  
Sept. 2-6, 1991) (91BR5326)
- CHATTOPADHYAY T., McINTYRE G.J., VETTER C., BROWN P.J.,  
FORSYTH J.B.  
Magnetic excitations and spin correlations in CuO.  
Physica B (proceedings of the International Conference on Neutron  
Scattering, Oxford, August 27-30, 1991) (91CH5065)
- CHATTOPADHYAY T., BRÜCKEL T., BURLET P.  
Spin correlations in MnS<sub>2</sub>.  
Physica B (proceedings of the International Conference on Neutron  
Scattering, Oxford, August 27-31, 1991) (91CH5129)
- CHATTOPADHYAY T., GRÜBEL G., AXE J.D., GIBBS D.  
X-ray resonance magnetic scattering in EuAs<sub>3</sub>.  
Journal of Magnetism and Magnetic Materials (proceedings of the  
International Conference on Magnetism, ICM'91, Edinburgh,  
Sept. 2-6, 1991) (91CH5061)
- CHATTOPADHYAY T., BROWN P.J., STEPANOV A.A., ZVYAGIN  
A.I., BARILO S.N., ZHIGUNOV D.I.  
Antiferromagnetic ordering in Gd<sub>2</sub>CuO<sub>4</sub>.  
Journal of Magnetism and Magnetic Materials (proceedings of the  
International Conference on Magnetism, ICM'91, Edinburgh,  
Sept. 2-6, 1991) (91CH5062)
- CHENEVIER B., BARUCHEL J., BACMANN M., FRUCHART D.,  
FRUCHART R.  
Neutron diffraction and topographic investigation of the multiphase  
magnetic-transition in MnRhAs.  
Journal of the Less Common Metals (91CH5315)
- ELLERBY M., McEWEN K.A., NEEDHAM L.M.,  
Magnetic ordering in praseodymium alloys.  
Physica B (proceedings of the International Conference on Neutron  
Scattering, Oxford, August 27-30, 1991) (91EL5355)
- FERNÁNDEZ-DÍAZ M.T., RODRÍGUEZ-CARVAJAL J.,  
MARTÍNEZ J.L.  
Crystalline and magnetic structure of Ln<sub>2</sub>NiO<sub>4</sub> (Ln=La,Pr,Nd).  
in "Spanish Scientific Research using Neutron Scattering Techniques  
(1986-1991)", eds. Gómez-Sal J.C., Rodríguez-Gonzalez F., Plazaola F.,  
Rojo T. (Servicio de Publicaciones de la Universidad de Cantabria)  
(91FE5256)
- FERNÁNDEZ-DÍAZ M.T., RODRÍGUEZ-CARVAJAL J., MARTÍNEZ  
J.L., ODIER P.  
Low temperature phase and magnetic ordering in Pr<sub>2</sub>NiO<sub>4</sub>.  
Physica B, (proceedings of the International Conference on Neutron  
Scattering, Oxford, August 27-30, 1991) (91FE5243)

- GARCÍA-MUÑOZ J.L., RODRÍGUEZ-CARVAJAL J., KILCOYNE S.H., BOARDMAN C.J., CYWINSKI R.  
Magnetic correlations in  $\text{YBa}_2(\text{C}_{1-x}\text{Fe}_x)_3\text{O}_{6+y}$ .  
Journal of Magnetism and Magnetic Materials (proceedings of the International Conference on Magnetism, ICM'91, Edinburgh, Sept. 2-6, 1991) (91GA5177)
- GARCÍA-MUÑOZ J.L., RODRÍGUEZ-CARVAJAL J., OBRADORS X.  
Magnetism in the rare earth cuprates  $\text{R}_2\text{Cu}_2\text{O}_5$  (R=Y, Ho, Er, Yb, Tm).  
Journal of Magnetism and Magnetic Materials (proceedings of the International Conference on Magnetism, ICM'91, Edinburgh, Sept. 2-6, 1991) (91GA5178)
- GARCÍA-MUÑOZ J.L., RODRÍGUEZ-CARVAJAL J., OBRADORS X.  
Complex magnetism in the rare earth cuprates  $\text{R}_2\text{Co}_2\text{O}_5$  (R=Y, Ho, Er, Yb, Tm).  
in "Spanish Scientific Research using Neutron Scattering Techniques (1986-1991)", eds. Gómez-Sal J.C., Rodríguez-Gonzalez F., Plazaola F., Rojo T. (Servicio de Publicaciones de la Universidad de Cantabria) (91GA5179)
- GARCÍA-MUÑOZ J.L., RODRÍGUEZ-CARVAJAL J., LACORRE P.  
Electronically induced structural distortion across the metal-insulator transition in  $\text{RNiO}_3$  (R=Pr, Nd, Sm).  
in "Spanish Scientific Research using Neutron Scattering Techniques (1986-1991)", eds. Gómez-Sal J.C., Rodríguez-Gonzalez F., Plazaola F., Rojo T. (Servicio de Publicaciones de la Universidad de Cantabria) (91GA5180)
- HINRICHS K., BRÜCKEL T., KNORR K., PRANDL W.  
Percolation like behaviour in amorphous spin glasses  
 $\text{Mn}_x\text{Ca}_{3-x}\text{Al}_2(\text{SiO}_4)_3$ .  
Physica B (proceedings of the International Conference on Neutron Scattering, Oxford, August 27-30, 1991) (91HI5323)
- HOCK R., BARUCHEL J., FUESS H., ANTONINI B., PAROLI P.  
The spin reorientation in erbium iron garnet : a neutron and X-ray topographical study.  
Journal of Magnetism and Magnetic Materials (proceedings of the International Conference on Magnetism, ICM'91, Edinburgh, Sept. 2-6, 1991) (91HO5316)
- IBARRA M.R., MARQUINA C., PAVLOVIC A.S., RITTER C.  
Structural and magnetic phase diagram of the series  $(\text{Tb}_x\text{Y}_{1-x})\text{Cu}$ .  
Journal of Magnetism and Magnetic Materials (proceedings of the International Conference on Magnetism, ICM'91, Edinburgh, Sept. 2-6, 1991) (91IB5309)
- ISNARD O., MIRAGLIA S., SOUBEYROUX J.L., PANNETIER J., FRUCHART D.  
Neutron powder diffraction study of  $\text{Pr}_2\text{Fe}_{17}$  and  $\text{Pr}_2\text{Fe}_{17}\text{N}_{2.9}$ .  
Physical Review B (91IS5212)
- ISNARD O., MIRAGLIA S., FRUCHART D., DEPORTES J.  
Magnetization properties of  $\text{RE}_2\text{Fe}_{17}\text{H}_x$  compounds.  
Journal of Magnetism and Magnetic Materials (91IS5213)
- ISNARD O., MIRAGLIA S., SOUBEYROUX J.L., FRUCHART D.,  
Neutron powder diffraction study of  $\text{R}_2\text{Fe}_{17}\text{H}_x$  compounds with R = Pr and Nd.  
Solid State Communications (91IS5214)
- JEHAN D.A., McMORROW D.F., COWLEY R.A., McINTYRE G.J.,  
The magnetic structure of holmium in an easy-axis magnetic field.  
Journal of Magnetism and Magnetic Materials (proceedings of the International Conference on Magnetism, Edinburgh, September 2-7, 1991) (91JE5128)
- JEHAN D.A., McMORROW D.F., COWLEY R.A., McINTYRE G.J.  
The magnetic structure of holmium in an easy-axis magnetic field.  
Europhysics Letters (91JE5321)
- KRIMMEL A., LOIDL A., GEIBEL C., McINTYRE G.J.  
Magnetic order in  $\text{UCu}_{4+x}\text{Al}_{8-x}$ .  
Journal of Magnetism and Magnetic Materials (91KR5322)
- KRIMMEL A., LOIDL A., GEIBEL C., STEGLICH F., McINTYRE G.J.  
Neutron diffraction experiments on  $\text{UCu}_{4+x}\text{Al}_{8-x}$ .  
Journal of Magnetism and Magnetic Materials (proceedings of the International Conference on Magnetism ICM'91, Edinburgh, September 2-6, 1991) (91KR5088)
- LACORRE P., FERREY G., PANNETIER J.  
The magnetic structure of  $\text{Cr}_2\text{F}_5$ .  
Journal of Solid State Chemistry (91LA5007)
- MARMEGGI J.C., BACMANN M., CHENEVIER B., FRUCHART D.  
Magnetic neutron white beam diffraction through phase transitions in MnRhAs.  
Physica B (proceedings of the International Conference on Neutron Scattering, Oxford, August 27-30, 1991) (91MA5306)
- MARTÍNEZ J.L., CEBOLLADA A., GALLEGO J.M., DE MIGUEL J.J., OCAL C., MIRANDA R., FERRER S.  
Neutron diffraction study on the antiferromagnetic ordering in Co-Cu superlattices.  
in "Spanish Scientific Research using Neutron Scattering Techniques (1986-1991)", eds. Gómez-Sal J.C., Rodríguez-Gonzalez F., Plazaola F., Rojo T. (Servicio de Publicaciones de la Universidad de Cantabria) (91MA5348)
- MEDARDE M., RODRÍGUEZ-CARVAJAL J., OBRADORS X., VALLET-REGI M., GONZALES-CALBET J.M., ALONSO J.  
Spin reorientations in  $\text{Nd}_{1.8}\text{Sr}_{0.2}\text{NiO}_{3.8}$ .  
Physica B (proceedings of the International Conference on Neutron Scattering, Oxford, August 27-30, 1991) (91ME5091)
- MONDAL S., CYWINSKI R., KILCOYNE S.H., RAINFORD B.D., RITTER C.  
Pressure dependence of the magnetic order in  $\text{YMn}_2$  and  $\text{TbMn}_2$ .  
Physica B (proceedings of the International Conference on Neutron Scattering Oxford, August 27-30, 1991) (91MO5108)
- MONDAL S., KILCOYNE S.H., CYWINSKI R., RAINFORD B.D., RITTER C.  
Suppression of local moment formation in Ce doped  $\text{YMn}_2$ .  
Journal of Magnetism and Magnetic Materials (91MO5220)
- del MORAL A., SCHWEIZER J., ARNAUDAS J.I., SALAMON M.B., RITTER C., JOVEN E., GEHRING P.M., ALGARABEL P.A., CULLEN J.  
Ferro-, quasiferro- and antiferromagnetic spin glass orders in random anisotropy crystalline  $\text{Dy}_x\text{Y}_{1-x}\text{Al}_2$  compounds.  
Journal of Magnetism and Magnetic Materials (proceedings of the International Conference on Magnetism ICM'91, Edinburgh, September 2-6, 1991) (91DE5109)
- MORÓN M.C., PALACIO F., RODRÍGUEZ-CARVAJAL J.  
Neutron powder diffraction experiments on  $\text{AMnF}_4$  (A=K, Rb): Nuclear and magnetic structures.  
Physica B (proceedings of the International Conference on Neutron Scattering, Oxford, August 27-30, 1991) (91MO5251)
- MURPHY H.M., NEUMANN K.U., VISSER D., ZIEBECK K.R.A.  
Investigation of the crystallographic properties of  $\text{CeSi}_x$  and their relation to a magnetically ordered ground state.  
Physica B (proceedings of the International Conference on Neutron Scattering, Oxford, August 27-30, 1991) (91MU5232)

- MURPHY H.M., NEUMANN K.U., VISSER D., ZIEBECK K.R.A.  
Crystallographic structure and magnetic ground state of  $CeSi_x$ .  
Journal of Magnetism and Magnetic Materials (proceedings of the  
International Conference on Magnetism, ICM'91, Edinburgh,  
Sept. 2-6, 1991) (91MU5233)
- NUÑEZ P., TRESSAUD A., MASSA W., BABEL D., BOIREAU A.,  
SOUBEYROUX J.L.  
Magnetic structures of some 1d-, 2D- and 3D- fluorides containing Jahn-  
Teller Elements.  
in "Spanish Scientific Research using Neutron Scattering Techniques  
(1986-1991)", eds. Gómez-Sal J.C., Rodríguez-Gonzalez F., Plazaola F.,  
Rojo T. (Servicio de Publicaciones de la Universidad de Cantabria),  
(91NU5192)
- NUÑEZ P., TRESSAUD A., DARRIET J., HAGENMULLER P., HAHN  
G., FRENZEN G., MASSA W., BABEL D., BOIREAU A.,  
SOUBEYROUX J.L.  
A new linear chain compound : crystal and magnetic structures of  
 $Tl_2Mn_5.H_2O$ .  
Inorganic Chemistry (91NU5193)
- NUÑEZ P., TRESSAUD A., GRANNEC J., HAGENMULLER P.,  
MASSA W., BABEL D., BOIREAU A., SOUBEYROUX J.L.  
Crystal and magnetic structures of the layer compound  $TiMnF_4$ .  
Zeitschrift für Anorganische und Allgemeine Chemie (91NU5195)
- NUNEZ V., TRUMP R., BROWN P.J., CHATTOPADHYAY T.,  
LOEWENHAUPT M., TASSET F.  
Antiferromagnetism of the Kondo lattice compound  $CeCu_2$  studied by  
neutron polarimetry.  
Journal of Physics : Condensed Matter (91NU5140)
- NUNEZ V., BROWN P.J., CHATTOPADHYAY T., FORSYTH J.B.,  
TASSET F.  
Magnetic structure determination using zero-field neutron polarimetry.  
Physica B (proceedings of the International Conference on Neutron  
Scattering, Oxford, August 27-30, 1991) (91NU5299)
- NUTLEY M.P., BOOTHROYD A.T., McINTYRE G.J.  
Magnetisation density in  $PrBa_2Cu_3O_7$  by polarized neutron diffraction.  
Journal of Magnetism and Magnetic Materials (proceedings of the  
International Conference on Magnetism, ICM'91, Edinburgh,  
Sept. 2-6, 1991) (91NU5310)
- OULADDIAF B., DEPORTES J., GALERA R.M., MARKOSYAN A.S.,  
SOUBEYROUX J.L.  
The 3d Mn magnetism instability in  $TbMn_2$ .  
Physica B (proceedings of the International Conference on Neutron  
Scattering, Oxford, August 27-31, 1991) (91OU5132)
- PAIXÃO J.A., LANDER G.H., BROWN P.J., NAKOTTE H., DE BOER  
F.R., BRÜCK E.  
Magnetisation density in  $URhAl$ . Evidence for hybridisation effects.  
Journal of Physics: Condensed Matter (91PA5078)
- PALACIO F., MORÓN M.C., RODRÍGUEZ-CARVAJAL J.  
Structural and magnetic properties of low-dimensional Mn(III) bimetallic  
fluorides.  
in "Spanish Scientific Research using Neutron Scattering Techniques", eds.  
Gómez-Sal J.C., Rodríguez-Gonzalez F., Plazaola F., Rojo T. (Servicio de  
Publicaciones de la Universidad de Cantabria) (91PA5252)
- PIERRE J., AUFFRET S., LAMBERT-ANDRON B., MADAR R.,  
MURANI A.P., SOUBEYROUX J.L.  
Magnetic and transport properties of rare earth silicides  $RSi_{2-x}$ .  
Journal of Magnetism and Magnetic Materials (proceedings of the  
International Conference on Magnetism, ICM'91, Edinburgh,  
Sept. 2-6, 1991) (91RO5360)
- POUGET S., ALBA M., FANJAT N., NOGUES M.,  
Crystal structure and magnetic interactions in  $CdCr_2S_4$  : a simple insulating  
ferromagnet.  
Physica B (proceedings of the International Conference on Neutron  
Scattering, Oxford, August 27-30, 1991). (91PO5099)
- RITTER C., MONDAL S., KILCOYNE S.H., CYWINSKI R., RAINFORD  
B.D.  
The magnetic phase diagram of  $(Dy_xY_{1-x})Mn_2$  alloys.  
Journal of Magnetism and Magnetic Materials (proceedings of the  
International Conference on Magnetism, ICM'91, Edinburgh,  
Sept. 2-6, 1991) (91RI5060)
- RITTER C., CYWINSKI R., KILCOYNE S.H., MONDAL S.  
The magnetic structure of  $HoMn_2$ .  
Journal of Physics : Condensed Matter (91RI5261)
- ROESSLI B., ALLENSPACH P., FISCHER P., FURRER A., MESOT J.,  
STAUB U., MALETTA H., BRÜESCH P., RITTER C., HEWAT A.W.  
Crystal structures and long-range antiferromagnetic ordering due to rare  
earth ions ( $R^{3+}$ ) in superconductors  $RBa_2Cu_3O_{7-\delta}$  ( $R=Nd, Yb$ ).  
Physica B (proceedings of the International Conference on Neutron  
Scattering, Oxford, August 27-30, 1991) (91RO5307)
- SALINAS-SANCHEZ A., SAEZ-PUCHE R., RODRÍGUEZ-CARVAJAL  
J., MARTÍNEZ J.L.  
Polymorphism and magnetic properties of  $Tm_2BaNiO_5$ .  
Materials Physics and Chemistry (proceedings of the 2nd Workshop on  
Basic and Applied Aspects of Rare Earths, Venice (Italy), May 9-10, 1991)  
(91SA5253)
- SANDONÍS J., BARUCHEL J.  
Topographic studies of antiferromagnetic single crystals.  
in "Spanish Scientific Research using Neutron Scattering Techniques", eds.  
Gómez-Sal J.C., Rodríguez-Gonzalez F., Plazaola F., Rojo T. (Servicio de  
Publicaciones de la Universidad de Cantabria) (91SA5340)
- SANDONÍS J., BARUCHEL J., SCHLENKER M., PEARCE A.  
The shape of the interface between the heli and ferromagnetic phases.  
Journal of Magnetism and Magnetic Materials (proceedings of the  
International Conference on Magnetism, ICM'91, Edinburgh,  
Sept. 2-6, 1991) (91SA5312)
- SANDONÍS J., PEARCE A., BARUCHEL J., PARLINSKI K.,  
PALMER S.B.  
Temperature variation related movement of chirality domain walls in  
helimagnets.  
Journal of Magnetism and Magnetic Materials (proceedings of the  
International Conference on Magnetism, ICM'91, Edinburgh,  
Sept. 2-6, 1991) (91SA5313)
- SANDONÍS J., BARUCHEL J., TANNER B.K., FILLION G.,  
KVARDAKOV V.V., PODURETS K.M.  
Coupling between antiferro and ferromagnetic domains in hematite.  
Journal of Magnetism and Magnetic Materials (proceedings of the  
International Conference on Magnetism, ICM'91, Edinburgh,  
Sept. 2-6, 1991) (91SA5314)
- SAPIÑA F., SANCHIS M.J., IBAÑEZ R., BELTRÁN A.,  
RODRÍGUEZ-CARVAJAL J., GARCÍA-MUÑOZ J.L.  
Crystal and magnetic structures of  $Bi_2CuO_4$  and  $Li_2CuO_2$ .  
in "Spanish Scientific Research using Neutron Scattering Techniques  
(1986-1991)", eds. Gómez-Sal J.C., Rodríguez-Gonzalez F., Plazaola F.,  
Rojo T. (Servicio de Publicaciones de la Universidad de Cantabria)  
(91SA5346)

TANNER B.K., BARUCHEL J., ABELL J.S.  
Internal magnetic domain structures changes in thick TbAl<sub>2</sub> crystals revealed by polarized neutron topography.  
Journal of Magnetism and Magnetic Materials (proceedings of the International Conference on Magnetism, ICM'91, Edinburgh, Sept. 2-6, 1991) (91TA5317)

## 6. Liquids, Disordered Materials and Metal Physics

AKAMATSU M., BOURGOIN J., JANOT C., MOZER P., VAN DUYSSEN J.C.  
Evolution of the microstructure of ferritic alloys after high fluence irradiations.  
Proceedings of the "2ème séminaire franco-japonais de Science des Matériaux", 1991 (91AK5045)

ALEKSEEV P.A., LAZUKOV V.N., ORLOV V.G., SADIKOV I.P., SUCK J.-B.  
Inelastic magnetic neutron scattering study of amorphous to crystal transition for PrNi<sub>5</sub>.  
Physica B (proceedings of the International Conference on Neutron Scattering, Oxford, August 27-30, 1991) (91AL5247)

ALTORFER F., BÜHRER W., ANDERSON I.S., SCHÄRPF O., BILL H., CARRON P.L., SMITH H.G.  
Lithium diffusion in the superionic conductor Li<sub>2</sub>S.  
Physica B (proceedings of the International Conference on Neutron Scattering, Oxford, August 27-30, 1991) (91AL5171)

ALTORFER F., BÜHRER W., ANDERSON I.S., SCHÄRPF O., BILL H., CARRON P.L., SMITH H.G.  
Structural and dynamical properties of Li<sub>2</sub>S.  
Proceedings of the ICAM'91, Strasbourg (91AL5172)

ANDERSEN K.H., STIRLING W.G., SCHERM R., STUNAUULT A., FÅK B., GODFRIN H., DIANOUX A.J.  
Precision determination of S(Q,ω) of liquid <sup>4</sup>He as a function of temperature.  
Physica B (proceedings of the International Conference on Neutron Scattering, Oxford, August 27-30, 1991) (91AN5224)

ANDERSEN K.H., STIRLING W.G., TAYLOR A.D., BENNINGTON S.M., BOWDEN Z.A., BAILEY I., GLYDE H.R.  
Final-state effects in S(Q,ω) of liquid <sup>4</sup>He at intermediate momentum transfer.  
Physica B (proceedings of the International Conference on Neutron Scattering, Oxford, August 27-30, 1991) (91AN5298)

ANGLADA M., ISALGUÉ A., RODRÍGUEZ-CARVAJAL J.  
Plastic strain effects on the stability of the spinodal decomposition in a superferritic stainless steel.  
in "Spanish Scientific Research using Neutron Scattering Techniques (1986-1991)", eds. Gómez-Sal J.C., Rodríguez-Gonzalez F., Plazaola F., Rojo T. (Servicio de Publicaciones de la Universidad de Cantabria) (91AN5347)

ARBE A., ALEGRIA A., ALVAREZ F., COLMENERO J., FRICK B.  
Dynamics of the α-relaxation in glass-forming polymeric systems. Study by neutron scattering and relaxation techniques.  
Colloid and Polymer Science (supplement) (proceedings of the 27th Europhysics Conference on Macromolecular Physics, Crete, September 23-27, 1991) (91AR5271)

BARTSCH E., DEBUS O., FUJARA F., KIEBEL M., PETRY W., SILLESCU H.  
Dynamic anomalies and their relation to glass transitions : a neutron scattering study of glass forming van der Waals liquids.  
Physica B (proceedings of the International Conference on Neutron Scattering, Oxford, August 27-30, 1991)

BERMEJO F.J., GARCÍA-HERNÁNDEZ M., MOMPEÁN F.J., CHAHID A., ALVAREZ M., MARTÍN D., ALONSO J., MARTÍNEZ J.L., ENCISO E., ALMARZA N.G.  
Dynamic correlations in disordered molecular systems.  
in "Spanish Scientific Research using Neutron Scattering Techniques (1986-1991)", eds. Gómez-Sal J.C., Rodríguez-Gonzalez F., Plazaola F., Rojo T. (Servicio de Publicaciones de la Universidad de Cantabria) (91BE5351)

BERMEJO F.J., GARCÍA-HERNÁNDEZ M., MOMPEÁN F.J., CHAHID A., ALVAREZ M., MARTÍN D., ALONSO J., MARTÍNEZ J.L., ENCISO E., ALMARZA N.G.  
Microscopic structure of molecular fluids by neutron diffraction.  
in "Spanish Scientific Research using Neutron Scattering Techniques (1986-1991)", eds. Gómez-Sal J.C., Rodríguez-Gonzalez F., Plazaola F., Rojo T. (Servicio de Publicaciones de la Universidad de Cantabria) (91BE5352)

BERMEJO F.J., MARTÍNEZ J.L., MARTÍN-MARERO D., MOMPEÁN F.J., GARCÍA-HERNÁNDEZ M., CHAHID A.  
Coherent excitations in liquid deuterium.  
Physica B (proceedings of the International Conference on Neutron Scattering, Oxford, August 27-30, 1991) (91BE5080)

BERMEJO F.J., MARTÍNEZ J.L., MOMPEÁN F.J., CHAHID A., GARCÍA-HERNÁNDEZ M.  
Inelastic scattering from molecular liquids and glasses.  
Physica B (proceedings of the International Conference on Neutron Scattering, Oxford, August 27-30, 1991) (91BE5081)

BOISSIEU M. DE, DURAND-CHARRE M., BASTIE P., CARABELLI A., BOUDARD M., BESSIERE M., LEFEBVRE S., JANOT C., AUDIER M.  
Centimeter size single grain of the perfect AlPdMn icosahedral phase.  
Philosophical Magazine (91BO5353)

BROADBENT R.D., NEILSON G.W., SANDSTRÖM M.  
The hydration of Cr<sup>3+</sup> in concentrated solution.  
Journal of Physics : Condensed Matter (Liquids) (91BR5318)

BUCHENAU U., MONKENBUSCH M., REICHENAUER G., FRICK B.  
Inelastic Neutron scattering from virgin and densified aerogels.  
Journal of Non Crystalline Solids (proceedings of the International Conference ISA-3, Würzburg, Sept. 30 - Oct. 2, 1991) (91BU5202)

CHAHID A., BERMEJO F.J., ENCISO E., GARCÍA-HERNÁNDEZ M., MARTÍNEZ J.L.  
Single-particle dynamics of liquid CCl<sub>4</sub>: a comparison of molecular dynamics and neutron quasi-elastic scattering results.  
Journal of Physics: Condensed Matter (91CH5330)

COLMENERO J., ARBE A., ALEGRIA A., FRICK B.  
Quasielastic neutron scattering study of the dynamics of the α-relaxation in polymers.  
World Scientific Publ. Co. (proceedings of the 3rd International Workshop on Non-Crystalline Solids, Matalascañas (Spain), November 5-8, 1991) (91CO5272)

DIANOUX A.J.  
Quasi-elastic and inelastic neutron scattering by time-of-flight spectroscopy.  
Proceedings of the International School of Physics Enrico Fermi, Course CXIV 'Industrial and Technological Applications of Neutrons', Lerici-La Spezia, June 19-29, 1990. (90DI5108)

FANJAT N., LUCAZEAU G., DIANOUX A.J.  
Study of Na<sub>3</sub>Fe<sub>2</sub>(PO<sub>4</sub>)<sub>3</sub> and Na<sub>3</sub>Cr<sub>2</sub>(PO<sub>4</sub>)<sub>3</sub> in their paramagnetic phases by neutron scattering.  
Journal of Physics and Chemistry of Solids (91FA5019)

FERNÁNDEZ-BARQUÍN L., VÁZQUEZ M., BARANDIARÁN J.M.,  
RODRÍGUEZ-CARVAJAL J.

Neutron thermodiffraction study on the Co-Si-B metallic glasses.  
in "Spanish Scientific Research using Neutron Scattering Techniques  
(1986-1991)", eds. Gómez-Sal J.C., Rodríguez-Gonzalez F., Plazaola F.,  
Rojo T. (Servicio de Publicaciones de la Universidad de Cantabria)  
(91FE5349)

FRICK B.

Incoherent inelastic neutron scattering on highly crystalline  
(1,4)-trans-polybutadiene.  
Proceedings of the Workshop on Disorder in Molecular Solids (II), Garchy,  
June 24-27, 1991 (91FR5284)

GOFF J.P., CLAUSEN K., FÅK B., HADFIELD R., HAYES W.,  
HULL S., HUTCHINGS M.T.

Diffuse neutron scattering from anion-excess strontium chloride.  
Physica B (proceedings of the International Conference on Neutron  
Scattering, Oxford, August 27-30, 1991) (91GO5260)

HAHN W., LOEWENHAUPT M., FRICK B.

Crystal field excitations in dilute rare earth noble metal alloys.  
Physica B (proceedings of the International Conference on Neutron  
Scattering, Oxford, August 27-30, 1991) (91HA5269)

HEIMING A., PETRY W., TRAMPENAU J., MIEKELEY W.,  
COCKCROFT J.

The temperature dependence of the lattice parameters of pure bcc-Zr and  
bcc-Zr-2at.%Co.  
Journal of Physics C (91HE5294)

HERDMAN G.J., NEILSON G.W.

The coordination of Fe(II) in a concentrated aqueous solution.  
Journal of Physics : Condensed Matter (Liquids) (91HE5319)

HERDMAN G.J., NEILSON G.W.

The hydration of Fe(II) ions in a concentrated ferrous chloride solution.  
Journal of Physics : Condensed Matter (Liquids) (91HE5320)

HILFRICH K., NEMBACH K., PETRY W., SCHÄRPF O., NEMBACH E.

Superlattices in iron-rich iron-aluminium alloys.  
Physica B (proceedings of the International Conference on Neutron  
Scattering, Oxford, August 27-30, 1991) (91HI5166)

HINRICHS K., HERZ K., KNORR K., MAY H.-J., POHL J., PRANDL W.

Experimental evidence for a second transition due to Ising ions in  
amorphous Heisenberg spin glasses.  
Journal of Magnetism and Magnetic Materials (proceedings of the  
International Conference on Magnetism, ICM'91, Edinburgh,  
Sept. 2-6, 1991) (91HI5324)

ISNARD O., MIRAGLIA S., FRUCHART D., BOURSIER D.,  
L'HERITIER P.

Coercivity in hydrogen-decrepitated  $\text{Sm}_2\text{Co}_{17}$ -type compounds.  
Journal of Alloys and Compounds (91IS5227)

JANOT C.

Quasicrystals structures with neutron diffraction.  
Nuclear Science and Engineering (90JA5107)

JANOT C., DE BOISSIEU M., BOUDARD M., VINCENT H., DURAND  
M., DUBOIS J.M., DONG C.

Single crystal X-ray diffraction study of AlPdMn icosahedral quasicrystal.  
Journal of Non Crystalline Solids (91JA5141)

JANOT C.

Quasicrystals : a step by step approach.  
book, Oxford University Press Publ. (91JA5186)

NEMBACH E., HILFRICH K., EBEL T., SCHÄRPF O.

Order in commercial grain-oriented iron-silicon sheets.  
Physica B (proceedings of the International Conference on Neutron  
Scattering, Oxford, August 27-30, 1991) (91NE5165)

NEUMANN K.U., SCHÄRPF O., ZIEBECK K.R.A.

On the question of the origin for a spherical average in scattering  
experiments.  
Physica B (proceedings of the International Conference on Neutron  
Scattering, Oxford, August 27-30, 1991) (91NE5170)

PIERON-BOHNES V., CADEVILLE M.C., SCHÄRPF O.

Influence of magnetic order on chemical order in  $\text{FeAl}_{19.5}$  at%.  
Proceedings of the conference on "III ordered materials", Saclay,  
Summer 1990 (91PI5190)

SIMON C., FAIVRE G., ZORN R., BATALLAN F., LEGRAND J.F.

Neutron spin echo study of the dynamics of undercooled selenium.  
Journal de Physique (91SI5366)

SUCK J.-B.

Experimental investigation of the atomic dynamics of amorphous and  
icosahedral alloys.  
Journal of Non-Crystalline Solids (91SU5245)

SUCK J.-B., EGELSTAFF P.A., ROBINSON R.A., SIVIA D.S.,  
TAYLOR A.D.

Neutron Brillouin scattering in a metallic glass.  
Journal of Non-Crystalline Solids (91SU5246)

TORRELLES X., BORDAS S., CLAVAGUERA N.,  
CLAGAGUERA-MORA M.T.

Structural relaxation in  $\text{Ge}_x\text{Se}_{1-x}$  glasses.  
in "Spanish Scientific Research using Neutron Scattering Techniques  
(1986-1991)", eds. Gómez-Sal J.C., Rodríguez-Gonzalez F., Plazaola F.,  
Rojo T. (Servicio de Publicaciones de la Universidad de Cantabria)  
(91TO5350)

WAGNER W., AVERBACK R.S., HAHN H., PETRY W.,  
WIEDENMANN A.

Sintering characteristics of nanocrystalline  $\text{TiO}_2$  - A study combining small  
angle neutron scattering and nitrogen absorption-BET.  
Journal of Materials Research (91WA5015)

WAGNER W., BÖNI P., WIEDENMANN A., PETRY W., BIRINGER R.

Neutron scattering study of magnetic correlations in nanostructured Fe.  
Physica B (proceedings of the International Conference on Neutron  
Scattering, Oxford, August 27-30, 1991)

WIEDENMANN A., LI Q., WAGNER W., WOLLENBERGER H.,  
PETRY W.

Fractal aggregation in Fe-Ni alloys during high temperature annealing.  
Physica B (proceedings of the International Conference on Neutron  
Scattering, Oxford, August 27-30, 1991)

WILLIAMS J.H., TORBET J.,

Measurements of the Cotton-Mouton effect of water and of several aqueous  
solutions.  
Journal of Physical Chemistry (91WI5106)

## 8. Biological Structures and Dynamics

BURNS N.R., SAIBIL H.R., WHITE N.S., PARDON J., TIMMINS P.A.,  
RICHARDSON M.H., PEARL L.H., ADAMS S.E. KINGSMAN A.J.,  
KINGSMAN S.M., RICHARDS B.M.

Symmetry and flexibility in the assembly of yeast retrotransposon virus-like  
particles.  
EMBO Journal (91BU5302)

CAVATORTA F., DERIU A., MALIZIA F., TERECH P., MIDDENDORF H.D.

Small angle neutron scattering from DNA molecules during gel electrophoresis.  
Progress in Colloid and Polymer Science (91CA5297)

EBEL C., GUINET F., LANGOWSKI J., URBANKE C., GAGNON J., ZACCAI G.

Solution studies of elongation factor Tu from the extreme halophile *H. marismortui*.  
Journal of Molecular Biology (91EB5208)

EISENBERG H., MEVARECH M., ZACCAI G.

Biochemical, structural and molecular genetics aspects of Halophilism.  
Advances in Protein Chemistry (91EI5303)

LEHMANN M.S., PEBAY-PEYROULA E.

Location of the sulphur atoms from the phased anomalous map using native protein data can be very helpful in tracing the peptide chain.  
Acta Crystallographica B (Letter to the Editor) (91LE5145)

MAY R.P., NOWOTNY V., NOWOTNY P., VOSS H., NIERHAUS K.H.

Inter-protein distances within the large subunit from *E. coli* ribosomes.  
EMBO Journal (91MA5204)

## 9. Chemistry

### 9a - Molecular Spectroscopy, Surfaces and Mesophases

AL USTA K., DOSCH H., LIED A., PEISL J.

Neutron diffraction under grazing incidence : recent results from the EVAnescent wave diffractometer.  
Springer Verlag (proceedings of the 2nd International Conference on Surface X-ray and Neutron Scattering, Bad Honnef (Germany), June 25-28, 1991) (91AL5250)

BEAUFILS J.P.

Polarized neutron diffraction by D<sub>2</sub> chemisorbed on a nickel powder.  
Journal of Applied Crystallography (91BE5237)

BLANK H., KEARLEY G.J.

The effect of anion substitution in nickel hexammine salts.  
Journal de Physique (proceedings of the Colloque Weyl VII, International Conference on Metals in solution, Aussois, France, June 23-28, 1991) (91BL5163)

CARLILE C.J., MUKHOPADHYAY R., SILVER R.N., FILLAUX F., PRAGER M., KEARLEY G.J., HEIDEMANN A., COCKCROFT J.

Higher resolution and numerical deconvolution : complementary techniques for complex spectra ?  
Physica B (proceedings of the International Conference on Neutron Scattering, Oxford, August 27-30, 1991) (91CA5334)

CHATTOPADHYAY T., FRICK B.,

Hydrogen motions and structural phase transitions in ZnTiF<sub>6</sub>·6H<sub>2</sub>O and MnTiF<sub>6</sub>·6H<sub>2</sub>O.  
Physica B (proceedings of the International Conference on Neutron Scattering, Oxford, August 27-30, 1991) (91CH5090)

DEROLLEZ P., BEE M., JOBIC H.

Inelastic neutron scattering in the glassy and metastable phases of methoxy-benzylidene-butyl-aniline.  
Spectrochimica Acta (90DE5045)

ECKERT J., KUBAS G.J., WHITE R.P.

The barrier to rotation of dihydrogen in Cr(CO)<sub>3</sub>(PCy<sub>3</sub>)<sub>2</sub>(η<sup>2</sup>-H<sub>2</sub>), a complex with an unusually high difference in solid and solution state stabilities.  
Inorganic chemistry (91EC5135)

FILLAUX F., CARLILE C.J., KEARLEY G.J.

Methyl tunneling and quantum sine-Gordon breather modes in partially deuterated 4-methyl-pyridine.  
Physica B (proceedings of the International Conference on Neutron Scattering, Oxford, August 27-30, 1991) (91FI5335)

FILLAUX F., FONTAINE J.P., BARON M.H., TOMKINSON J., KEARLEY G.J.

Inelastic neutron scattering intensities and force-field calculations : normal versus local mode picture.  
Physica B (proceedings of the International Conference on Neutron Scattering, Oxford, August 27-30, 1991) (91FI5336)

GOMEZ-GARCÍA C.J., CORONADO E., BORRAS-ALMENAR J.J., ABERSOLD M., GÜDEL H.U., MUTKA H.

Magnetic excitations in an exchange-coupled tetramer cluster of cobalt(II). A study by inelastic neutron scattering.  
Physica B (proceedings of the International Conference on Neutron Scattering, Oxford, August 27-30, 1991) (91GO5267)

GUILLAUME F., REY-LAFON M., PETRY W., DIANOUX A.J., RIEUTORD F.

Reorientational motions of the alkyl chains in C<sub>10</sub>H<sub>21</sub>ND<sub>3</sub>Cl bidimensional crystal.  
Physica B (91GU5222)

JOBIC H., BEE M., KEARLEY G.J.

Dynamics of ethane and propane in zeolite ZSM-5 studied by quasi-elastic neutron scattering.  
Zeolites (91JO5329)

KEARLEY G.J.

The application of normal coordinate analysis to INS spectra  
Spectrochimica Acta (Review article : Physical Chemistry - Neutron Scattering) (91KE5205)

KEARLEY G.J., TOMKINSON J.

The inelastic neutron scattering spectrum of Sn(CH<sub>3</sub>)<sub>4</sub>.  
Physica B (proceedings of the International Conference on Neutron Scattering, Oxford, August 27-30, 1991) (91KE5207)

PRASSIDES K., BELL C.J., DIANOUX A.J., CHUN-GUEY Wu., KANATZIDIS M.G.

Phonon studies of intercalated conductive polymers.  
Physica B (proceedings of the International Conference on Neutron Scattering, Oxford, August 27-30, 1991) (91PR5184)

RAISON P., DELAPALME A., LANDER G.H., CARLILE C., WILLIAMS J.H., KANELLAKOPOULOS B., APOSTOLIDIS C., REBIZANT J.

Study of motion of cyclopentadienyl rings in UCp<sub>3</sub>Cl by quasielastic neutron scattering.  
Physica B (proceedings of the International Conference on Neutron Scattering, Oxford, August 27-31, 1991) (91RA5138)

SIMON C., ROSENMAN I., BATALLAN F., LARTIGUE C., LEGRAND J.F.

Measurement of the dynamics of a 2D dislocation mediated melting.  
Physical Review B (91SI5148)

TOMKINSON J., KEARLEY G.J.

The effect of recoil of chemically-distinct molecular ions on INS spectra of molecular vibrations.  
Physica B (proceedings of the International Conference on Neutron Scattering, Oxford, August 27-30, 1991) (91TO5217)

WILLIAMS J.H.

The effect of an electric field gradient on allowed rotational spectra.  
Journal of Physics B (91WI5057)

**9b - Colloids and polymer**

BALTA CALLEJA F.J., GONZALEZ ARCHE A., EZQUERRA T., SANTA CRUZ C., BATALLAN F., FRICK B., LOPEZ CABARCOS E. Structure and properties of ferroelectric copolymers of poly(vinylidene fluoride).

Advances in Polymer Science (91BA5287)

BUNE A.V., FRIDKIN V.M., VERKHOVSKAYA K.A., LEGRAND J.F. Absorption changes at the phase transition of ferroelectric copolymers doped by a cyanine dye.

Ferroelectrics (proceedings of the 7th European Meeting on Ferroelectricity, Dijon, July 8-12, 1991) (91BU5122)

CHARVOLIN J., SADO C J.-F.

Geometrical foundation of mesomorphic polymorphism.

in 'Modern ideas and problems in amphiphilic science', Gelbart W.M., Roux D. and Ben Shaul A. (Eds. Springer-Verlag Series on Partially Ordered Fluids) (91CH5012)

CHARVOLIN J., SADO C J.F.

Films of amphiphiles and minimal surfaces.

in 'Amphiphilic Membranes', ed. by R. Lipowsky (Springer Proceedings in Physics) (91CH5146)

EVEN J., CAILLEAU H., TOUDIC B., BERTAULT M., MOUSSA F., CURRAT R.

Neutron study of the structural transition in a polymerizable crystal : pTS-D.

Physica B (proceedings of the International Conference on Neutron Scattering, Oxford, August 27-30, 1991) (91EV5197)

EVEN J., BERTAULT M., TOUDIC B., CAILLEAU H., FAVE J.L., SCHOTT M., MOUSSA F., CURRAT R.

Dynamical study of the antiferroelectric transition in a polymer crystal : pTS-D.

Ferroelectrics (proceedings of the 7th European Meeting on Ferroelectricity, Dijon, July 8-11, 1991) (91EV5198)

GABRYS B., SCHÄRPF O.

Scattering from polymers using polarised neutrons : a new development.

Physica B (proceedings of the International Conference on Neutron Scattering, Oxford, August 27-30, 1991) (91GA5169)

KIRSTE R.G., SALIE H., LINDNER P.

The structure of polyetherketones.

Physica B (proceedings of the International Conference on Neutron Scattering, Oxford, Aug. 27-31, 1991) (91KI5123)

LAMERS C., SCHÄRPF O., SCHWEIKA W., BATOULIS J., SOMMER K., RICHTER D.

Short range order in amorphous polycarbonates.

Physica B (proceedings of the International Conference on Neutron Scattering", Oxford, August 27-30, 1991) (91LA5283)

LAUN H.M., BUNG R., HESS S., LOOSE W., HESS O., HAHN K., HAEDICKE E., HINGMANN R., SCHMIDT F., LINDNER P.

Rheological and small angle neutron scattering investigation of shear-induced particle structures of concentrated polymer dispersions submitted to plane poiseuille and couette flow.

Journal of Rheology (91LA5067)

LESIEUR P., LINDNER P., DESFORGE C., LAMBARD J., ZEMB T.

Comparison of pinhole and linearly collimated SAXS and SANS study of emulsified oil droplets.

Physica B (proceedings of the International Conference on Neutron Scattering, Oxford, Aug. 27-31, 1991) (91LE5125)

LINDNER P.

Large scale structures under shear.

Physica B (proceedings of the International Conference on Neutron Scattering, Oxford, Aug. 27-31, 1991) (91LI5124)

MOSSERI R., SADO C J.F., CHARVOLIN J.

Some remarks on the shape of toroidal vesicles.

in "Amphiphilic Membranes", edited by R. Lipowsky (Springer Proceedings in Physics) (91MO5147)

SAUVAJOL J.L., DJURADO D., DIANOUX A.J., FISCHER J.E.

Densités d'états des modes de réseau dans les polymères conjugués. Une étude par diffusion incohérente des neutrons.

Journal de Chimie Physique (proceedings of the 'Journées sur les Polymères Conducteurs', La Grande Motte, October 16-18, 1991) (91SA5262)

SCHURTENBERGER P., MAGID L., LINDNER P., LUISI P.L.

A sphere to flexible coil transition in lecithin reverse micellar solutions.

Progress in Colloid and Polymer Science (91SC5275)

TERECH P.

Structural features of some physical networks probed by small angle neutron scattering.

Croatica Chemica Acta (91TE5296)

TERECH P., SCHAFFHAUSER V., MALDIVI P., GUENET J.M.

Rheological and neutron scattering investigations of the jelly state of binuclear copper complexes in cyclohexane.

Europhysics Letters (91TE5149)

VERKHOVSKAYA K.A., BUNE A.V., FRIDKIN V.M., LEGRAND J.F.

Photoelectret and irradiation effects in ferroelectric polymers.

Polymer (90VE5030)

WONG K., LIXON P., LAFUMA F., LINDNER P.,

AGUERRE CHARRIOL O., CABANE B.

Intermediate structures in equilibrium flocculation.

Journal of Coll. Interface Science (90WO5148)

ZORN R., RICHTER D., FARAGO B., FRICK B., KREMER F.,

KIRST U., FETTERS L.J.

Comparative study of the segmental relaxation in polyisoprene by quasi-elastic neutron scattering and dielectric spectroscopy.

Physica B (proceedings of the International Conference on Neutron Scattering, Oxford, August 27-30, 1991) (91ZO5104)

ZORN R., RICHTER D., FRICK B., FARAGO B.

Neutron scattering experiments near the glass-transition of polybutadiene.

AIP Conference Proceedings Series (proceedings of the 1st Towa University International Symposium on Slow Dynamics in Condensed Matter, Towa (Japan), November 4-8, 1991) (91ZO5288)

### **Acknowledgement**

This report was compiled by SCAPRO  
(Scientific Coordination and Public Relations Office).  
The Scientific Secretary, Bernd P. Maier, editor of this report,  
wishes to thank all those who have contributed.

*Layout and typesetting by Idra*

*Cover layout and printing by Technic Color*

*Photography by S. Claisse, Studio de la Revirée  
and ARTECHNIQUE.*

### **Other publications available**

- Guide to Neutron Research Facilities, Edition 1988/89
- General Information and Regulations, Edition 1990  
both available from SCAPRO.
- Experimental Reports and Theory College Activities 1991  
available from the Library.

Scientific Coordination and Public Relations Office (SCAPRO)  
Institut Max von Laue - Paul Langevin  
BP 156  
38042 Grenoble Cedex 9  
France  
Telephone: 76207111 – Telefax: 76483906 – Telex: 320621



Institut Max von Laue  
Paul Langevin  
Grenoble - France