

# SECTION A-A

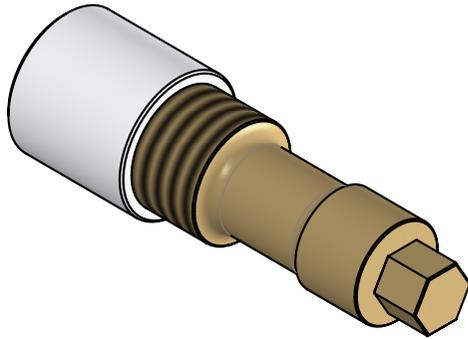
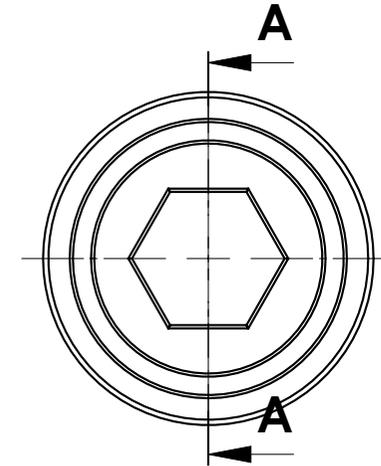
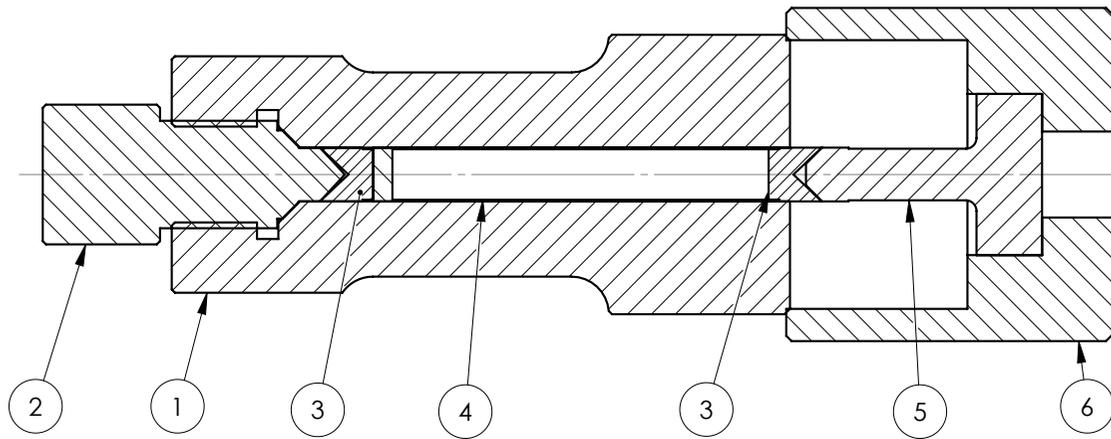

| Rep. | No.Plan         | Ind. | Désignation        | Matière          | Qté | Observations |
|------|-----------------|------|--------------------|------------------|-----|--------------|
| 1    | 04PCL-10-00-001 | A    | Clamp Body CuBe    | CuBe2            | 1   |              |
| 2    | 04PCL-10-00-002 | A    | Closing Screw Ø5   | CuBe2            | 1   |              |
| 3    | 04PCL-10-00-003 | A    | Clamp Joint Ø5     | Cu OFHC          | 2   |              |
| 4    | 04PCL-10-00-004 | A    | Clamp Container Ø5 | EN AW-5754 (AG3) | 1   |              |
| 5    | 04PCL-10-00-005 | A    | Piston Ø5          | Tungstene        | 1   |              |
| 6    | 04PCL-10-00-006 | A    | Closing Nut        | EN AW-7049A      | 1   |              |

|   |          |                          |               |   |                 |
|---|----------|--------------------------|---------------|---|-----------------|
| A   | 12-12-16 | J.Perez-Rios             | J.Gonthier    | E.Lelièvre-Berna  | Edition du plan |
| Ind.  | Date     | Dessinateur              | Vérificateur  | Resp.technique  | Modifications   |
| Tolérances générales:   |          | Rugosité:                | Matière:      | Traitement:   |                 |
| Linéaires: X  |          | X                        |               |   |                 |
| Angulaires: X   |          | Masse: 0.26 kg           | Observations: |   |                 |
| Echelle:  |          | SANE - High Pressure     |               | <br>INSTITUT LAUE LANGEVIN<br>6, rue Jules Horowitz - BP156<br>Grenoble Cedex 9 - France |                 |
| 2:1   |          | 12 Kbar liq. 04PCL120CB5 |               |   |                 |
|  |          | CuBe Clamp Assembly      |               | Ce dessin est la propriété de l'Institut et ne peut être reproduit ou communiqué sans son autorisation.   |                 |
| Format:   |          | N° de plan               |               | Page: 1/1   |                 |
| A3  |          | 04PCL-10-00-000          |               | Indice: A   |                 |