

ILL INSTRUMENT SUITE AND ENDURANCE

- Endurance 1 - completed
- Endurance 1 - in progress
- Endurance 2 - completed
- Endurance 2 - in progress

NEUTRON GUIDE HALL ILL22

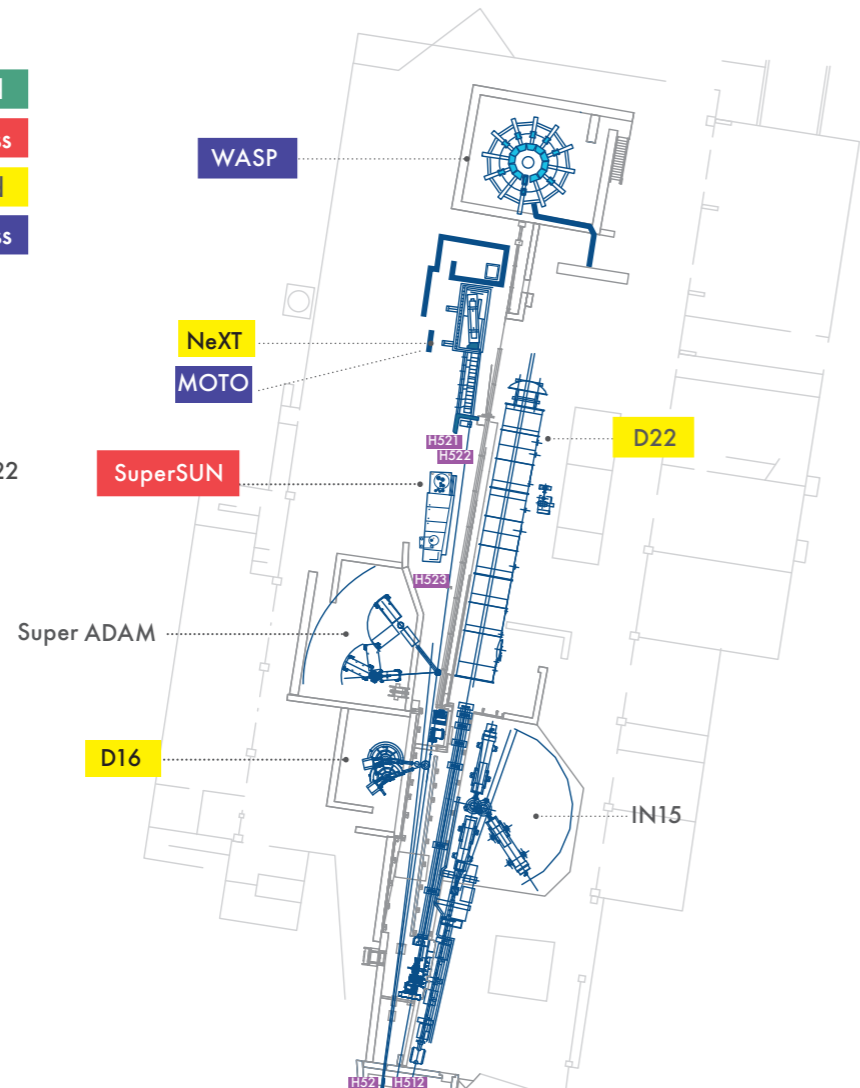

REACTOR BUILDING ILL5 LEVEL D

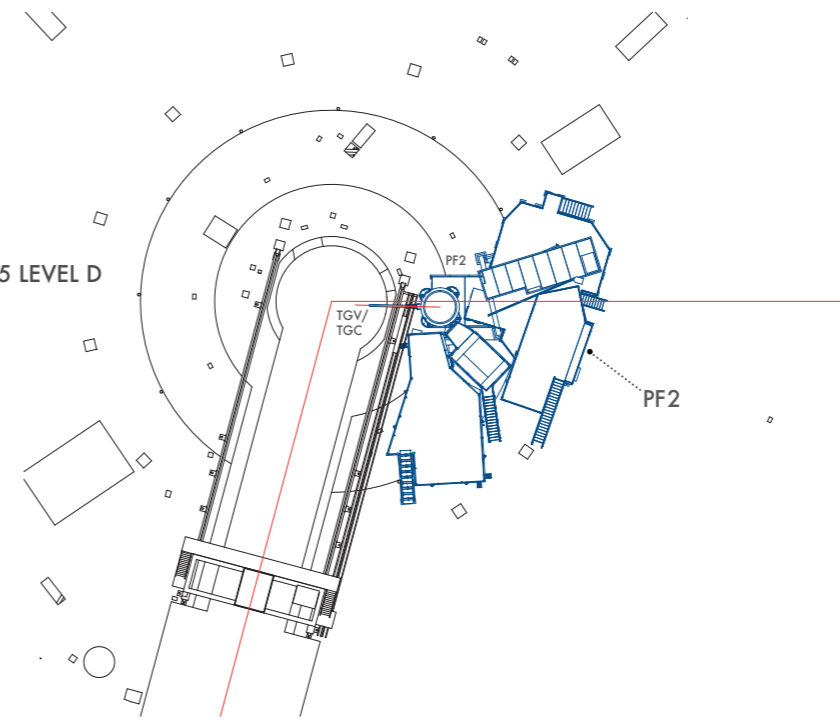

NEUTRON GUIDE HALL ILL7 - VERCORS SIDE (WEST)

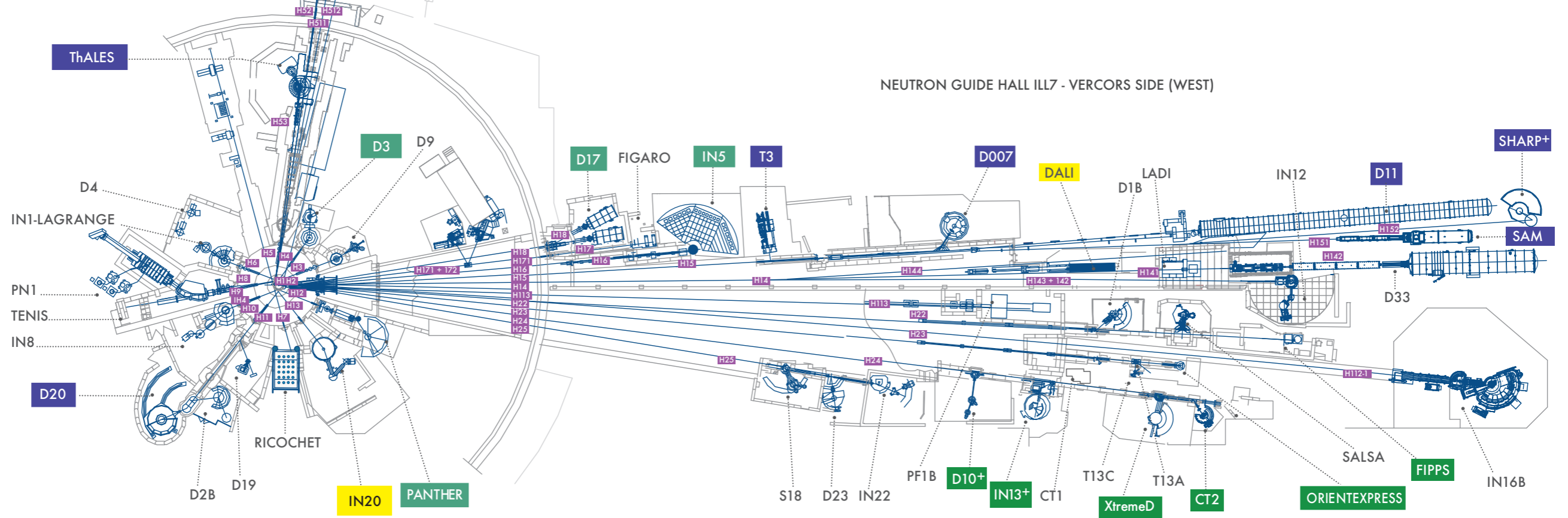

REACTOR BUILDING ILL 5 LEVEL C

NEUTRON GUIDE HALL ILL7 - CHARTREUSE SIDE (EAST)

THE INSTITUT LAUE LANGEVIN

ENDURANCE: A FULLY MODERNISED INSTRUMENT SUITE

During the H1-H2 shutdown, the Endurance programme takes a massive step forward in the installation of new neutron guide systems and instrumentation:

- Complete installation of the **H24** dual guide system (thermal neutrons).
- Installation of the four **H24** new or refurbished instruments: **D10+**, **XtremeD**, **IN13+** and **CT2** (commissioning Q1 2023).
- A free end-of-guide position on **H24** foreseen for future relocation of Fipps.
- Partial installation of the new **H15** multi-branch guide system (cold neutrons).
- Preparation of future experimental areas for the five new or upgraded **H15** instruments: **D007**, **D11+**, **Sam**, **Sharp+**, **T3** (commissioning Q3 2024).
- Installation of the new neutron imaging facility, **NeXT** (ILL22 guide hall).
- Complete replacement and upgrade of the in-pile H1-H2 beam tube, **H1** (cold) and **H2** (thermal) neutron guides delivering neutrons to all ILL7 instruments.
- Seismic-resistant neutron guide pass-through between the reactor building and ILL7 guide hall.

Other instrument upgrades:

PANTHER: New background chopper system.

IN20: New monochromator and analyser.

D16: New secondary spectrometer and large position-sensitive banana detector.

WASP: Fresnel coil maintenance.

IN16B: New variable guide for the BATS chopper system.

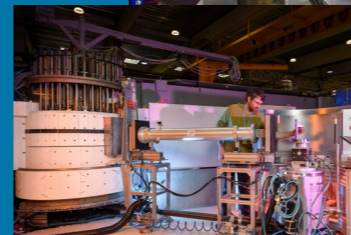
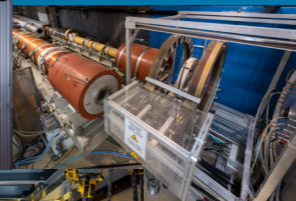
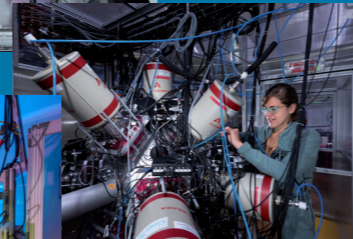
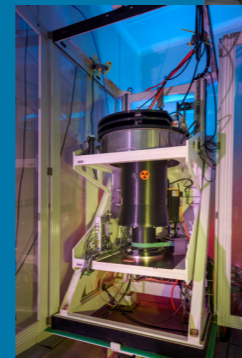
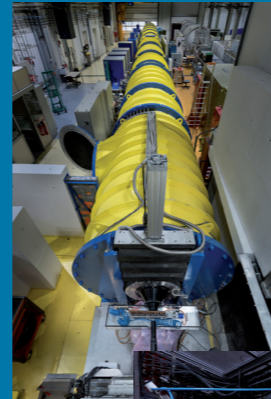

WORLD LEADER IN NEUTRON SCIENCE AND TECHNOLOGY

Institut Laue Langevin
71 avenue des Martyrs, Grenoble - France
www.ill.eu

